

# Water Penetration Resistance – Design and Detailing

**Abstract:** Brick masonry walls require proper design, detailing and construction to minimize water penetration into or through a wall system. Many aspects of design, construction and maintenance can influence the resistance of a wall to water penetration. The selection of the proper type of wall is of utmost importance in the design process, as is the need for complete and accurate detailing. In addition to discussing various wall types, this *Technical Note* covers proper design of brick masonry walls and suggests details that have been found to increase water penetration resistance.

**Key Words:** barrier, design, detailing, drainage, flashing, installation, rain, wall types, weeps.

## SUMMARY OF RECOMMENDATIONS:

### Wall System Selection

- Drainage walls provide maximum protection against water penetration by use of a drainage cavity
- Barrier walls provide good water penetration resistance by holding moisture within their mass until evaporation occurs
- Single wythe masonry walls provide adequate water penetration resistance when carefully detailed and constructed

### Through-Wall Flashing Locations

- Install flashing at wall bases, window sills, heads of openings, shelf angles, tops of walls and roofs, parapets, above projections (such as bay windows, balconies, decks), changes in grade, and transitions with other cladding materials
- For drainage walls, also install flashing at any other discontinuities in the cavity

### Through-Wall Flashing Installation

- Extending flashing to exterior wall face is required
- Lap continuous flashing pieces at least 6 in. (152 mm) and seal with compatible sealant or adhesive
- Turn up the ends of discontinuous flashing at least 1 in. (25.4 mm) to form end dams
- Support flexible flashing across gaps and openings
- Extending flashing beyond the exterior wall face is recommended
- For UV-sensitive flashing, use a drip edge

### Through-Wall Flashing Termination

- End flashing on vertical surface of backing
- Integrate flashing with weather-resistive barrier
- Protect edge of flashing from moisture:
  - Apply cap bead of sealant on edge of self-adhered flashing
  - Use of termination bar with sealant is preferred
  - Other options: Insert into bed joint in masonry or reglet in concrete

### Water-Resistive Barrier

- Required for wood or cold-formed steel backing; recommended for redundancy on masonry or concrete backing
- Use sheet membranes, fluid-applied films or board materials
- Integrate with flashing in shingled fashion to direct bulk water out of wall assembly
- Vapor permeability of material used depends on climate zone, wall assembly components and code requirements

### Air Barrier

- Required by building codes
- Generally placed on exterior face of backing
- Vapor permeability of material used depends on climate zone and wall assembly components

### Drainage Cavity

- Provide air space that drains properly with minimal mortar droppings
- A minimum 1 in. (25.4 mm) air space\* is required
- When continuous insulation is present, maintain minimum 1 in. (25.4 mm) air space\* between the back of the brick and the insulation
- For air space recommendations, consult appropriate *Technical Note* for project-specific wall assembly
- Use of drainage material or mortar collection devices recommended

\* An air space is allowed in the *IRC* to be a 1 in. (25.4 mm) nominal dimension and in the *IBC* to be a 1 in. (25.4 mm) specified dimension to account for construction tolerances.

### Weeps

- Open head joint weeps spaced at no more than 24 in. (610 mm) o.c. preferred
- Most building codes permit weeps no less than  $\frac{3}{16}$  in. (4.8 mm) in diameter and spaced no more than 33 in. (838 mm) o.c.
- When wick weeps used, spacing of no more than 16 in. (406 mm) o.c. is recommended
- Use of weep tubes is not recommended

# INTRODUCTION

This *Technical Note* is the first in a series addressing water resistance of brick masonry. Design considerations and details are provided to illustrate the principles involved in addressing water penetration issues. The other *Technical Notes* in this series provide detailed guidance in the areas of material selection (7A) and construction (7B). *Technical Note 47* provides information on condensation prevention and control.

When masonry walls encounter problems, water-related issues are often one of the primary factors. Brick masonry exposed to a disproportionate amount of water may have dimensional changes; efflorescence on exterior surfaces; and cracking, crazing, spalling or disintegration due to repeated freeze-thaw cycling. Water may also cause metals to corrode, insulation to lose its effectiveness and interior finishes to deteriorate. On susceptible wall elements, water penetration may also provide the moisture necessary for mold growth.

The water resistance of a masonry wall depends on four key factors: design, including detailing; materials; construction; and maintenance. Attention to all four is necessary to produce a wall that will perform satisfactorily. Failure to properly address any one factor can result in water penetration problems.

There are many sources of water that may affect masonry walls. Rain and snow contact exterior building materials directly. Water vapor is a constant presence in the air and can infiltrate or exfiltrate through seams and interfaces in the building envelope. Since water sources cannot be eliminated, the designer must instead control the potential for water penetration.

Historically, masonry walls functioned as both the structural system and as the exterior skin of the building. These masonry walls were quite massive, ranging in thickness from 12 in. (305 mm) up to 6 ft (1.83 m) of solid brick. Because of their thickness and their state of constant compression due to the structural loads, these walls worked quite well in keeping water out of the interior of the building. The large volume of masonry prevented moisture penetration to the interior due to the sheer mass of material. Historic mass masonry walls acted as a reservoir for any moisture absorbed, which was later released as vapor. Also, many older masonry walls were built with roof overhangs, cornices and other ornamentation that helped to protect the faces of the buildings from excessive water sheeting and subsequent water penetration to the interior.

The walls typically used today are much less massive, and the masonry may be 3 in. (76 mm) or less in thickness, greatly reducing the moisture storage capacity of the wall assembly. In many cases, walls have minimal overhang at the top, allowing sheeting of rainwater over the full height of the facade from the roof or parapet down to the ground. As a result, rainwater can be in contact with the masonry of these newer wall systems in larger quantities and for longer periods of time, leading to more opportunity for water penetration problems.

## DESIGN

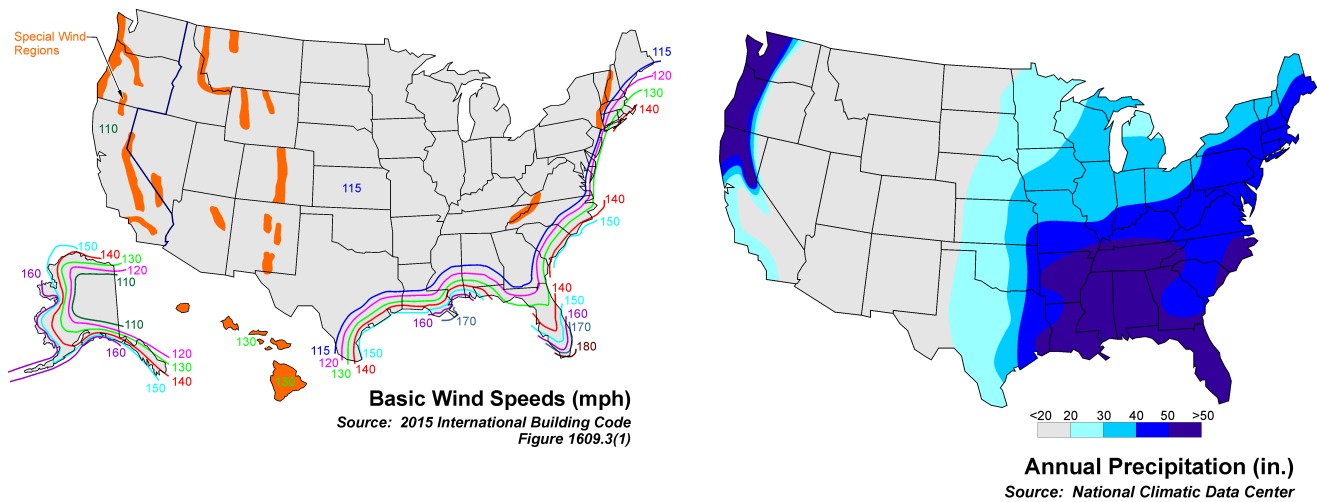
The successful performance of a masonry wall depends on limiting the amount of water penetration and controlling any water that enters the wall system. When water passes through brick masonry walls, it typically does so through minute separations between the brick units and the mortar joints. Under normal exposures, it is virtually impossible for significant amounts of water to pass directly through the brick units or through the mortar. Highly absorbent brick units will absorb some water but do not contribute to liquid (bulk) water penetration through a wall.

Design for water resistance requires evaluation of several items, including sources of moisture; selection of wall type; and the use of water-resistive barriers, flashing and weeps. This *Technical Note* addresses each of these items separately.

## Sources of Moisture

Moisture is present almost everywhere, in the form of rain, snow, condensation, groundwater, construction runoff, etc. Some of these lend themselves to control, but some do not. This *Technical Note* addresses wind-driven rain. The control of moisture-laden air and interstitial condensation is discussed in *Technical Note 47*.

When designing a masonry wall, consideration of exposure to wind-driven rain is important. Exposures vary greatly throughout the United States, from severe on the Eastern Seaboard and Gulf Coast, where rain durations of several hours may be accompanied by high-velocity winds; to moderate in the Midwest and Mississippi Valley,



**Figure 1**  
**U.S. Wind Speeds and Precipitation**

where wind velocities are usually lower; to slight in the arid areas of the West. No single wall design can be expected to perform equally well under all exposures. Refer to **Figure 1**.

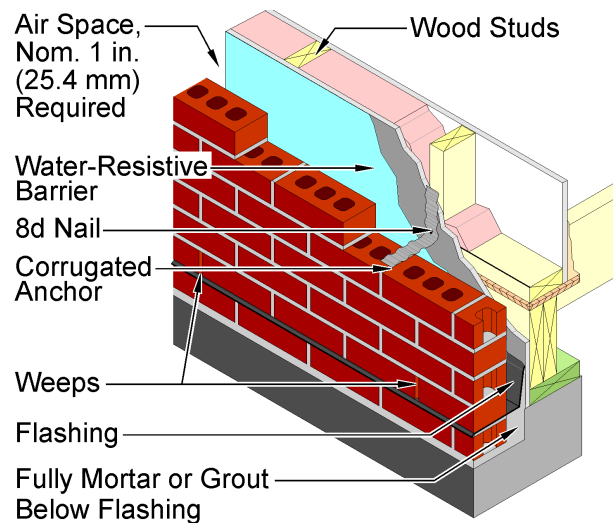
## Selection of Wall Type

The selection of the proper wall type to use in any given situation is very important. Under normal conditions, it is nearly impossible to keep a heavy wind-driven rain from penetrating a single wythe of brickwork, regardless of the quality of the materials or the degree of workmanship used.

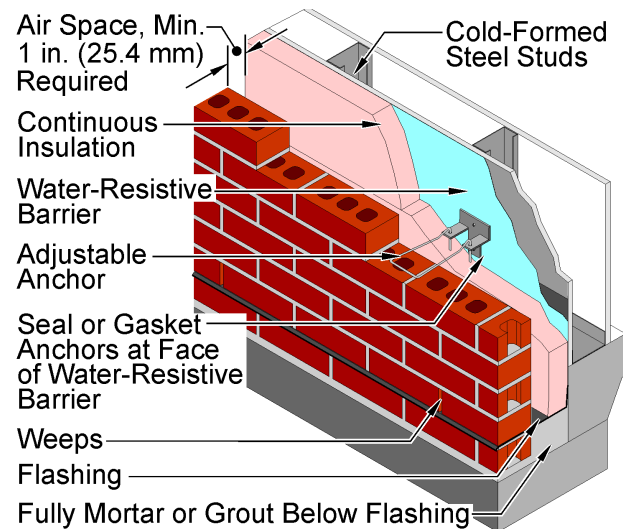
The best approach to designing a water-resistant wall is to assume that some water will penetrate the outer surface. Therefore, the objective is to control the moisture once it begins to penetrate the wall. Two basic wall systems are used for this purpose: the drainage wall and the barrier wall.

**Drainage Wall Systems.** Drainage wall systems include cavity walls and anchored veneer walls, as shown in **Figure 2**, **Figure 3**, **Figure 4** and **Figure 5**. Contemporary cavity walls use metal ties to connect the masonry wythes; however, a designer may encounter masonry-bonded hollow walls in historic applications. The guiding principle behind the drainage wall assumes that a heavy, wind-driven rain will result in moisture penetrating the exterior wythe of brickwork. When this occurs, the wall is designed to collect this moisture and redirect it out of the wall assembly.

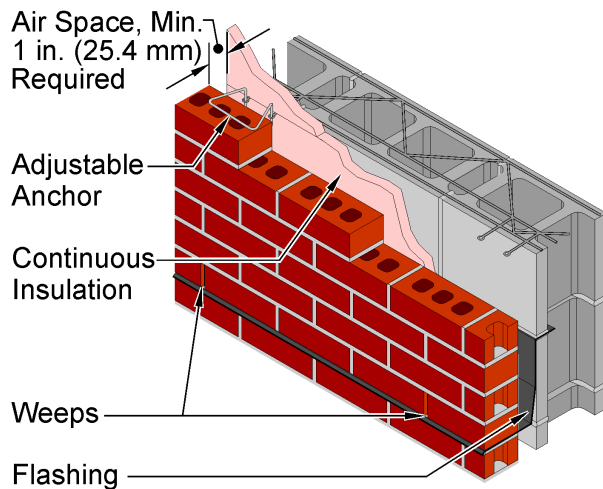
The water progresses down the drainage cavity, typically on the interior face of the outer brick wythe, where it is collected on the flashing and exits the wall system through the weeps. Properly designed, detailed and constructed drainage wall systems provide excellent water penetration resistance.



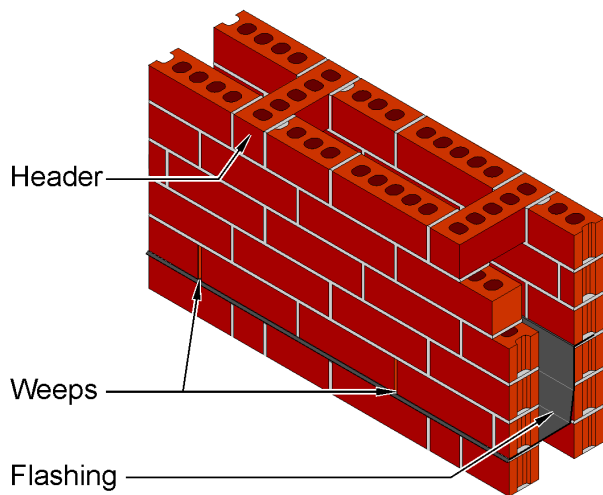
**Figure 2**  
**Brick Veneer/Wood Framing**



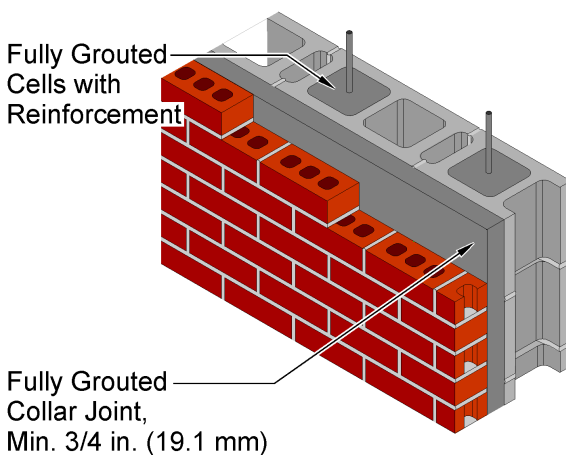
**Figure 3**  
**Brick Veneer/Cold-Formed Steel Framing**



**Figure 4**  
Brick Veneer/CMU Wall



**Figure 5**  
Masonry-Bonded Hollow Wall



**Figure 6**  
Reinforced Barrier Wall

Information on aspects specific to cavity wall systems can be found in the *Technical Note 21 Series*. The *Technical Note 28 Series* generically addresses both anchored and adhered veneer wall systems.

**Barrier Wall Systems.** Barrier wall systems, such as the one shown in [Figure 6](#), include mass masonry multi-wythe walls with mortar or grout-filled collar joints (including composite brick/concrete block walls and composite brick/structural clay tile walls), reinforced brick masonry walls and adhered veneer walls. The system relies on the thickness of the masonry and the integrity of the mortar or grout to prevent moisture from reaching the interior during the rain event. This moisture will slowly evaporate from the wall assembly during drier weather. Critical to the performance of this wall system is the integrity of the collar joint, as well as the bed and head joints between units. These joints must be solidly filled with grout or mortar; otherwise, the gaps create pathways that direct water to the interior and bypass the storage capacity of the wall assembly. Grouting is the most effective method of ensuring that collar joints are completely filled; however, spaces less than  $\frac{3}{4}$  in. (19.1 mm) should not be grouted. In these instances, the face of the inner masonry wythe should be parged and the back of brick in the exterior wythe buttered in order to fill the collar joint. Placing mortar in the collar joint with a trowel after the individual wythes are laid, commonly referred to as “slushing,” does not result in completely filled joints and is not recommended. Flashing is also integrated into barrier walls to aid in controlling water that penetrates the exterior wythe. Properly designed, detailed and constructed barrier wall systems work well with respect to water penetration resistance.

**Single-Wythe Walls.** Single-wythe masonry walls can be considered a variation of a barrier wall system. Single-wythe brick masonry construction can be designed with either solid or hollow units. In single-wythe walls, the masonry wythe usually exceeds the thickness of a nominal 4 in. (102 mm) exterior brick wythe. In addition to the added thickness, grouted cells help to prevent water from penetrating to the interior of the wall system. Inherently, single-wythe walls are not as resistant to water penetration as are drainage wall systems or multi-wythe barrier wall systems, and may not be appropriate for some severe exposures. With careful detailing and good construction practices, however, a single-wythe wall can perform well. For example, vertically reinforced and grouted brickwork often provides good water penetration resistance.

With single-wythe masonry, it is especially important to use a mortar joint profile that sheds rather than collects water. Concave and “V” joint profiles are preferred because they eliminate exposed horizontal surfaces on the brick, and the tooling procedure consolidates the outer surface of the mortar and compresses it against the sides of the joint, increasing the water penetration resistance of the mortar joint. See *Technical Note 7B* for further information. Penetrating water repellents can increase the moisture resistance of single-wythe walls; however, they will require periodic reapplication and are not equal to essential code-required drainage wall details. A water repellent may reduce some bulk water penetration through the brickwork, but it will not improve the ability of the wall to manage any water that does penetrate. Film-forming or acrylic-based water repellent coatings or sealers should be avoided. See *Technical Note 6A* for further information on water repellents.

## DETAILING

### Water-Resistive Barriers

The International Building Code (*IBC*) [Ref. 4] and the International Residential Code (*IRC*) [Ref. 5] require a weather-resistant exterior envelope to provide water resistance. They define a water-resistive barrier as a material behind an exterior wall covering that is intended to resist liquid (bulk) water that has penetrated behind the exterior covering from further intruding into the exterior wall assembly. For exterior walls with brick veneer and wood or cold-formed steel frame backing, a water-resistive barrier is required. A water-resistive barrier is not required on projects where exterior walls have concrete or masonry backing behind brick veneer, but one may be included for redundancy.

The water-resistive barrier is typically a sheet layer or fluid-applied membrane attached to the exterior face of the backing, or a board material qualified and installed as such. It is installed to provide a continuous drainage plane and is integrated with flashing in a shingled fashion to form a system that directs bulk water out of the wall. Where the water-resistive barrier is a sheet layer, it must be lapped. Where a fluid-applied membrane is used as a water-resistive barrier, most manufacturers require that gaps in the substrate be covered with a transition sheet or tape prior to the application of the liquid material. Similarly, board materials qualified to serve as water-resistive barriers must also have the joints between boards covered.

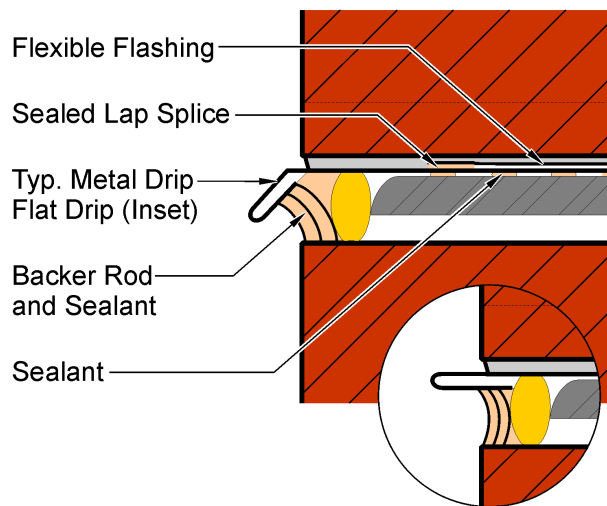
In-depth discussion of water-resistive barriers is outside the scope of the BIA *Technical Notes*. However, there are many building science resources available as reference [Ref. 1 and Ref. 3]. In cases with complicated buildings, consultation with building envelope professionals is recommended in order to develop project-specific recommendations for materials and placement of those materials in the wall assembly. Various types of materials that may be used in the design of brick masonry and brick veneer walls are discussed in *Technical Note 7A*.

### Air Barriers and Vapor Permeance

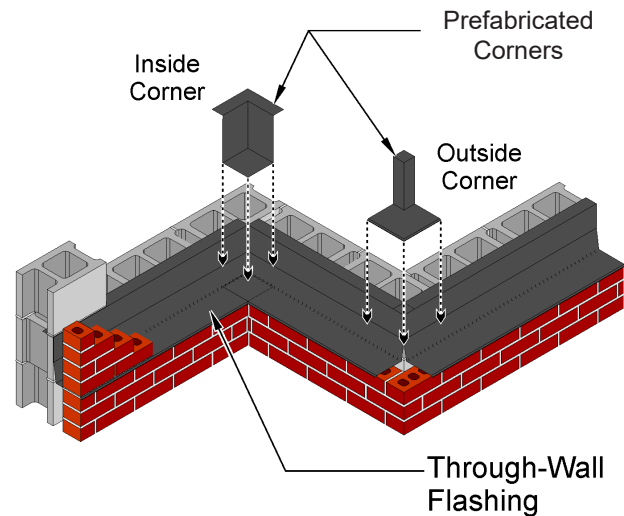
Air barriers and the vapor permeance of materials also play a role in moisture management, as they control the movement of water vapor. An air barrier controls air leakage through the building envelope, and a material's vapor permeance controls the amount of moisture that can pass through (vapor diffusion). As air movement accounts for significantly more water vapor movement in building cavities than does vapor diffusion, air barriers are generally considered to have a more significant impact on moisture control than the vapor permeance of a material. Both the *IBC* and *IRC* require air barriers in the wall assembly. For exterior walls with brick veneer, air barriers are usually placed on the exterior of the backing and may consist of a single material or a combination of materials. In some cases, a water-resistive barrier may also serve as an air barrier or a vapor retarder. Vapor retarders are classified by their level of permeance, as defined in the *IBC* and *IRC*. The vapor permeance of a material is generally more of a concern on the warm side of the building envelope. As a result, the interior side of exterior walls of wood or cold-formed steel framing of buildings located in Northern climate zones are required to have materials with a certain vapor permeance. For more information on air barriers, vapor retarders and vapor permeance of materials, refer to *Technical Note 7A*.

### Through-Wall Flashing

Through-wall flashing is an impervious material installed in a masonry wall system to contain water that has penetrated the exterior wythe and direct it back to the exterior. Such flashing is required in a drainage wall system and is critical to the ability of the wall to manage moisture. In a barrier wall system, such flashing is recommended as a second line of defense to moisture intrusion. Proper design requires flashing at wall bases, window sills, heads of openings, shelf angles, projections, recesses, bay windows, chimneys, tops of walls, and roofs. Sheet



**Figure 7**  
Drip Edge Detail



**Figure 8**  
Installation of Prefabricated Flashing Corners

metal and flexible membranes are the materials most frequently used to create flashing. Flashing should extend vertically up the backing a minimum of 8 in. (203 mm) above the horizontal leg.

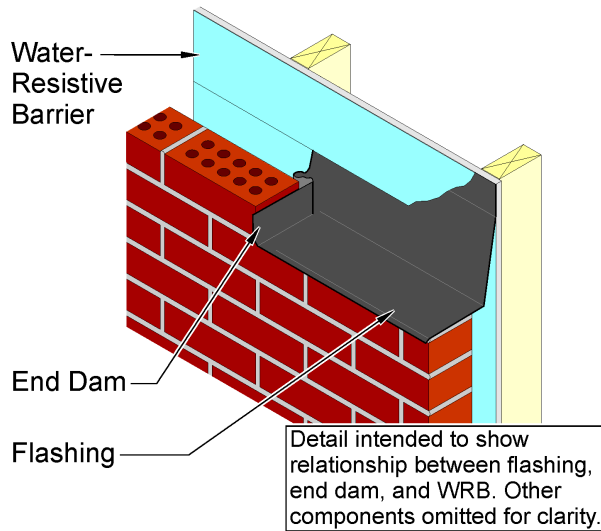
Through-wall flashing design and installation must also address the following:

**Compatibility.** Through-wall flashing materials and components must be compatible with one another and with the underlying substrates, including air barriers and vapor retarders. Through-wall flashing components must be compared so that materials in contact will adhere with no detrimental effects on the performance of the system. It is recommended to obtain self-adhered flashing, air barriers, vapor retarders and their auxiliary materials (including adhesive/primer and sealants) from a single manufacturer. Alternatively, provide manufacturer documentation confirming compatibility between adjacent materials in the wall assembly.

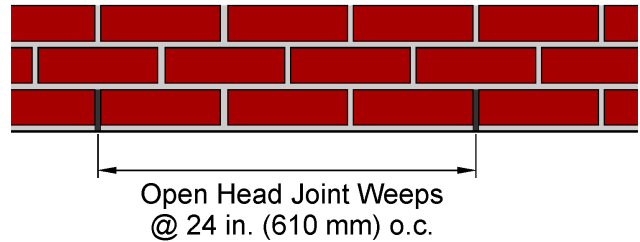
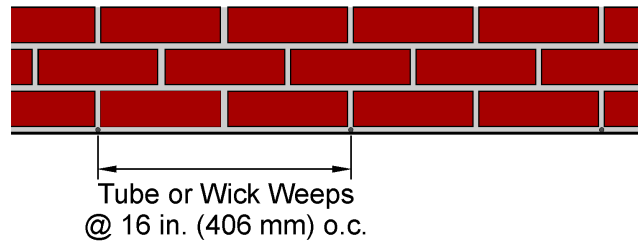
**Extension Through Wall.** While building codes permit flashings to be trimmed flush with the brick face, extending flashing beyond the face of the wall promotes improved drainage. When flashing does not extend beyond the brick face, surface tension can permit moisture to wick under the flashing or wet the surface of the brick below. Wherever possible, a drip should be formed to ensure that moisture exits the wall assembly and is directed away from the face of the wall below. Many popular flashing membranes deteriorate with UV exposure. In such cases, a sheet metal drip edge (typically stainless steel) can be paired with the membrane to address this issue, as shown in [Figure 7](#). The sheet metal drip is inert under UV exposure, which allows the membrane to remain concealed but still direct moisture beyond the face of the brick. This method is also effective at avoiding bleed from rubberized asphalt-based membranes, since the edge of the membrane will be recessed. Where the appearance of drips is considered objectionable, flat sheet metal drips can be formed using only a hemmed edge, eliminating the angled projection and minimizing their exposure.

**Substrate Adhesion and Support.** Flashing should be fully adhered to substrate material to prevent lateral migration of moisture in case of a breach. Self-adhered membranes should be rolled to ensure good bond to the substrate and to minimize air bubbles. Rigid flashing such as drip edges or sheet metal pans should be fully bedded in sealant or liquid membrane material. Rigid flashing can be self-supporting; however, flexible flashing requires continuous support and should not span or drape across gaps. Thin corrosion-resistant sheet metal can be used as a support in these conditions. Primers may be required per the manufacturer's directions.

**Continuity.** While some flashing locations are discrete, such as at window openings, other locations such as shelf angles or wall bases will be continuous around the entire building. As a result, pieces must be lapped or spliced at the project site. Plain flexible flashing sections should be lapped at least 6 in. (152 mm) and the laps adhered and edges sealed with a sealant or adhesive compatible with the flashing material. Self-adhesive flashing lap lengths are typically 3 to 4 in. (76 to 102 mm) and vary by manufacturer. The manufacturer's recommended sealant or liquid membrane should be used to protect the edges of the lap splice. Splices in sheet metal elements like drip edges can consist of a simple lap joint or a separate cover plate that conceals the ends of two adjacent flashing sections. Refer to the manufacturer's requirements for lap and splice details.



**Figure 9**  
End Dam Detail



**Figure 10**  
Spacing of Weeps

**Flashing Around Corners and Projections.** Continuity of flashing is critical. To achieve flashing continuity around corners, the pieces of flashing may be folded, lapped and sealed to conform to the shape of the structure. Alternatively, preformed corner and transition pieces are available, as shown in Figure 8. Specifying prefabricated flashing membrane corners reduces some of the potential for water penetration. If cuts are used, then the seams and edges should be well-sealed. Whether field-formed or prefabricated, overlap all edges and corners at least 6 in. (152 mm) and seal with an adhesive or detailing material compatible with the flashing. Inside and outside corners of stainless steel drips can be premanufactured as well to improve productivity and to achieve better quality control over soldered seams.

**End Dams.** Where the flashing is not continuous, such as above and below openings in the wall and on each side of vertical building expansion joints, the ends of the flashing should be turned up into the head joint at least 1 in. (25.4 mm) at each end to form a dam. At window and door openings, the head flashing should be extended beyond the jamb lines on both sides prior to forming the end dams. Preformed sheet metal end dams may also be used in combination with flexible flashing. End dams for rigid sheet metal flashing should be fully soldered. Refer to Figure 9 for an example of an end dam in a flexible flashing.

**Terminations.** Terminate flashing on the vertical surface of the backing and integrate with the water-resistive barrier to provide positive drainage. All flashing terminations must be supported and protected to ensure that they remain in place and that moisture cannot undermine them. In most cases, the water-resistive barrier will overlap the flashing; however, fluid-applied water-resistive barrier may have manufacturer-specific requirements. The vertical leg of flashing can be terminated in a variety of different ways. Flashing, both rigid and flexible, can be terminated into the bed joint of the interior masonry wythe or into horizontal slots (reglets) in concrete construction. For flexible flashing, using a termination bar is preferred. Termination bars are generally narrow plates with predrilled holes to receive fasteners. The termination bar is placed at the top of the vertical leg of flashing, fastened to the substrate, and sealed as shown in Figure 18. Alternatively, self-adhered flexible flashing can be terminated on the backing with a bead of compatible sealant along the top edge.

## Weeps

In order to adequately drain any water collected on the flashing, weeps are required at the level of the flashing at all locations. The practice of placing weeps in one or more courses of brick above the flashing will allow water to accumulate and is not recommended. An open head joint weep, formed by leaving mortar out of a joint, is the preferred type of weep. Open head joint weeps should be at least 2 in. (51 mm) high. Noncorrosive metal, mesh or plastic screens/vents can be installed in open head joint weeps if desired. These may be beneficial to discourage insect entry and to emphasize the purpose of the open head joints in order to reduce the risk of sealing during future maintenance work.

Other weep types include wicks and tubes. While not preferred, if used, wicks should be at least 16 in. (406 mm) long and extend through the brick wythe into the air space and along the back of the brick wythe. Weep tubes are not recommended due to an increased risk of clogging. Weeps are permitted by most building codes to have a minimum diameter of  $\frac{3}{16}$  in. (4.8 mm) [Ref. 2 and Ref. 5].

Spacing of open head joint weeps is recommended at no more than 24 in. (610 mm) o.c. Refer to [Figure 10](#). Weeps are permitted by most building codes to be spaced up to 33 in. (838 mm) o.c. [Ref. 2 and Ref. 5]. If used, spacing of wick or tube weeps is recommended at no more than 16 in. (406 mm) o.c.

## Drainage

To the extent possible, the air space must be kept clear of mortar and mortar droppings to achieve adequate drainage. An air space that provides drainage is permitted to contain mortar from construction. Building codes require a minimum 1 in. (25.4 mm) air space. The *IRC* requires a nominal 1 in. (25.4 mm) air space, and the *IBC* requires a specified 1 in. (25.4 mm) minimum air space. When continuous insulation is present within the air space, provide a minimum dimension of 1 in. (25.4 mm) (nominal or specified per applicable code) between the inside face of the brick and the insulation. BIA recommendations for air space dimensions vary depending on the type of construction. Consult the appropriate *Technical Note* for the project-specific wall assembly.

Drainage media may be specified that prevent mortar from entering the air space or that catch mortar droppings at the wall base. These materials are usually made of a plastic mesh or fabric porous enough to allow passage of water but that will catch or inhibit mortar from collecting at the base of the air space. The effects of mortar collection devices should be considered carefully, as they may require modifications to typical details such as extending the vertical leg of the flashing more than 8 in. (203 mm) above the weep line. Drainage media is permitted to fill the full depth of the air space. While it is not mandatory to include drainage materials, they may help in providing an air space that drains properly. However, the use of drainage media should not preclude good workmanship and an effort to keep mortar and mortar droppings out of the air space to the extent possible.

## Critical Flashing Locations

**Wall Base.** Moisture that enters a wall assembly gradually travels downward. Continuous flashing must be placed above grade at the base of walls to divert this moisture to the exterior. In addition, base flashing prevents groundwater from rising up into the wall system due to capillary action and helps prevent efflorescence. The elevation of flashing and weeps should be no more than 10 in. (254 mm) above finished ground level and should consider planting beds, ground coverings, sidewalks, etc. that are placed immediately adjacent to the wall. The *IRC* requires lots to be graded to drain surface water away from foundation walls and requires a minimum slope of 6 in. (152 mm) within the first 10 ft (3.05 m) of wall to provide positive drainage away from the wall.

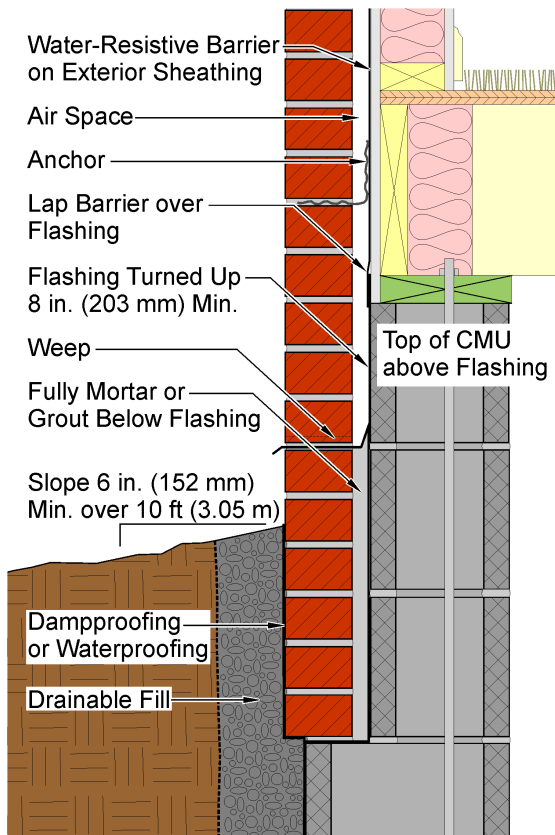
Once the designer has determined the level for placing flashing in the wall in accordance with the grading plans, care should be taken that field modifications do not result in any section of flashing being below grade. The location of the base flashing should be stepped to conform to significant changes in grade.

The top of the foundation wall should be above the elevation of the base flashing to prevent water from being directed toward the building interior. Refer to [Figure 11](#). The cavity below the base wall flashing should be solidly filled with mortar or grout. Anchors or ties within the solidly filled space should be located according to the same spacing as the brick veneer above grade. Where below-grade waterproofing or dampproofing is present, the transition to the above-grade moisture management system (water-resistive barrier and flashing) should be detailed and constructed to provide continuity at the wall base.

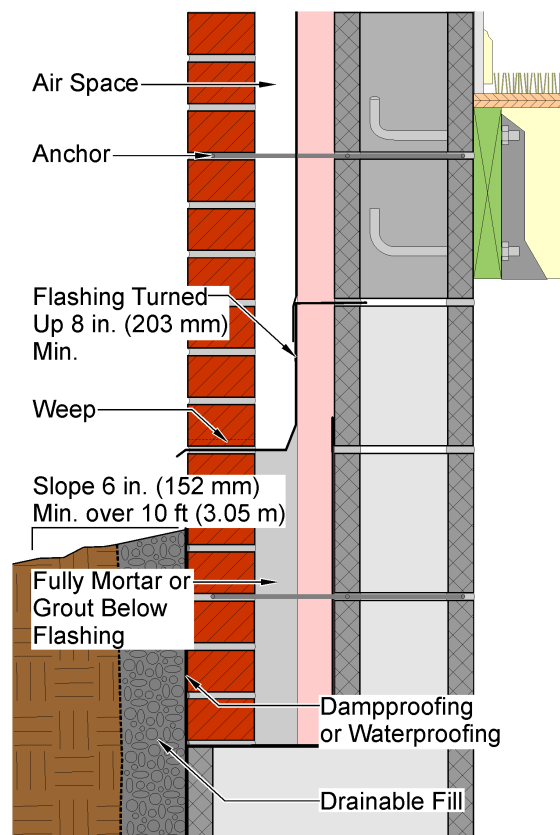
**Brickwork Below Grade.** Brickwork should extend below grade only when special provisions are made in detailing and construction to minimize water penetration. If brickwork extends below grade, then the soil immediately adjacent to the brickwork should provide good drainage. If the soil does not provide good drainage, then a drainable fill, drainage mat or drainage board that is detailed and constructed to drain water away from the brickwork should be provided between the soil and the brickwork (see [Figure 11a](#), [Figure 11b](#) and [Figure 11c](#)).

The *IRC* and *IBC* require the surfaces of walls against earth to be dampproofed or waterproofed. To avoid the application of dampproofing or waterproofing to brick veneer, the brick shelf in the foundation may be constructed above the final grade (see [Figure 11d](#)). If brickwork extends below grade, then dampproofing or waterproofing should be applied to the brickwork below grade in accordance with the *IRC* or *IBC*.

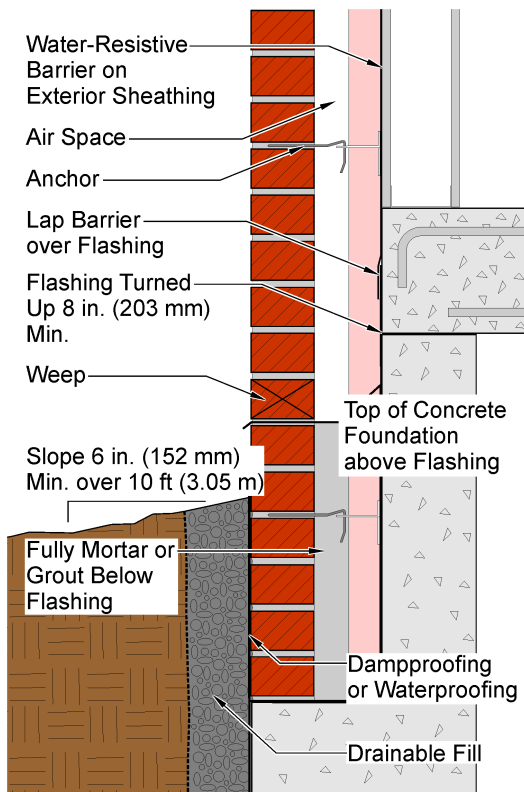




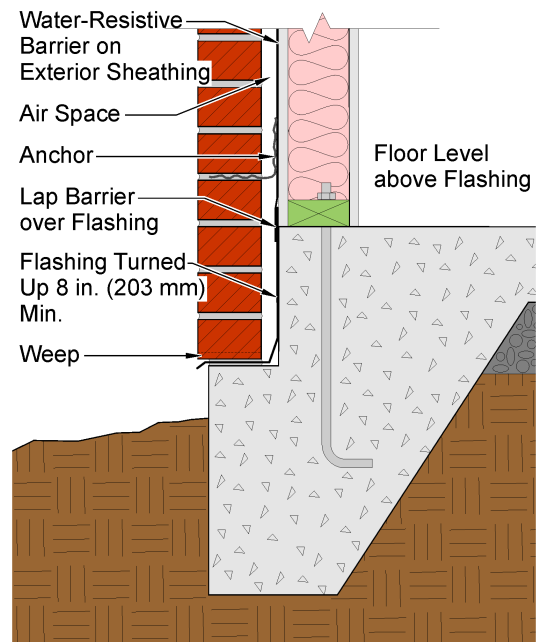
(a) Wood Stud on CMU Foundation



(b) CMU on CMU Foundation

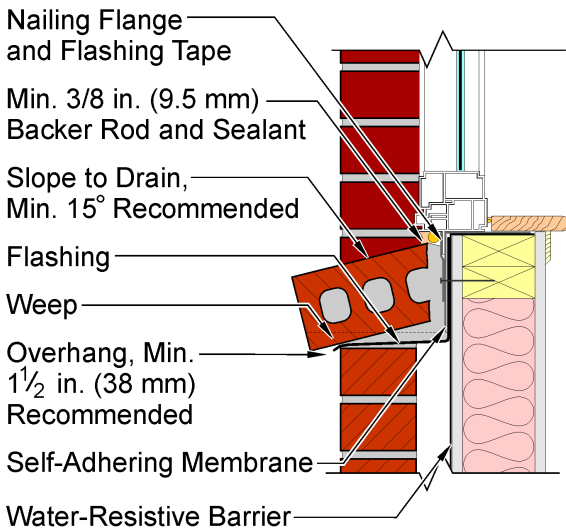


(c) Steel Stud on Concrete Foundation

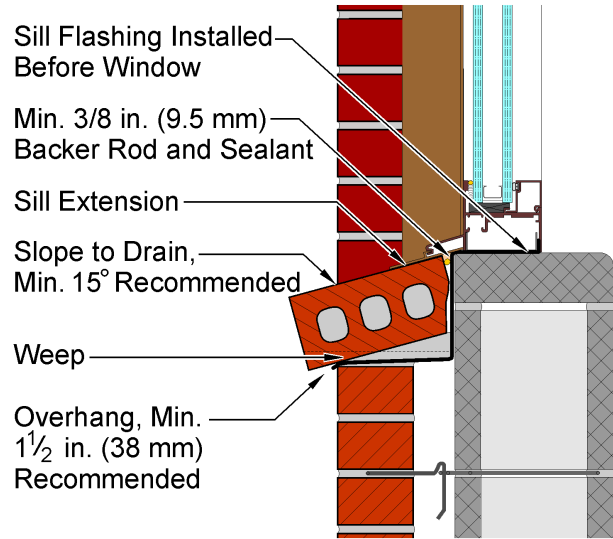


(d) Wood Stud on Turned-Down Slab

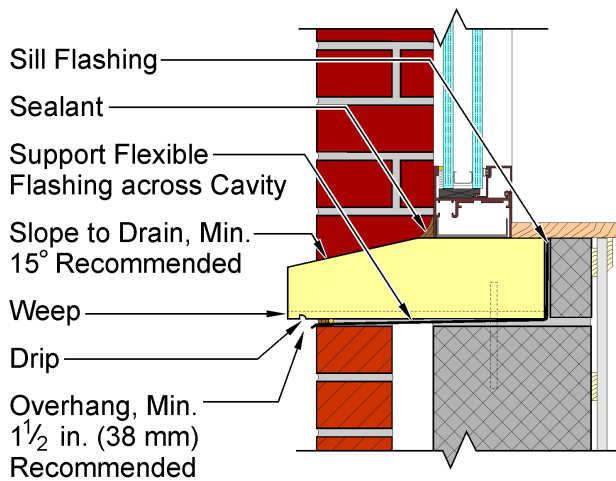
**Figure 11**  
**Flashing at Wall Bases**



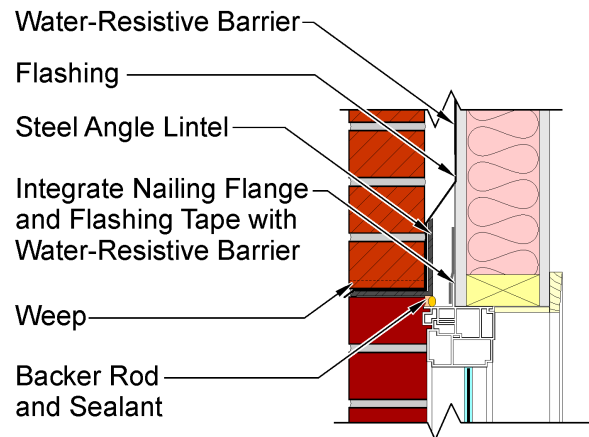
**Figure 12**  
Flanged Window Sill Detail



**Figure 13**  
Window Sill in Cavity Wall



**Figure 14**  
Stone or Concrete Window Sill

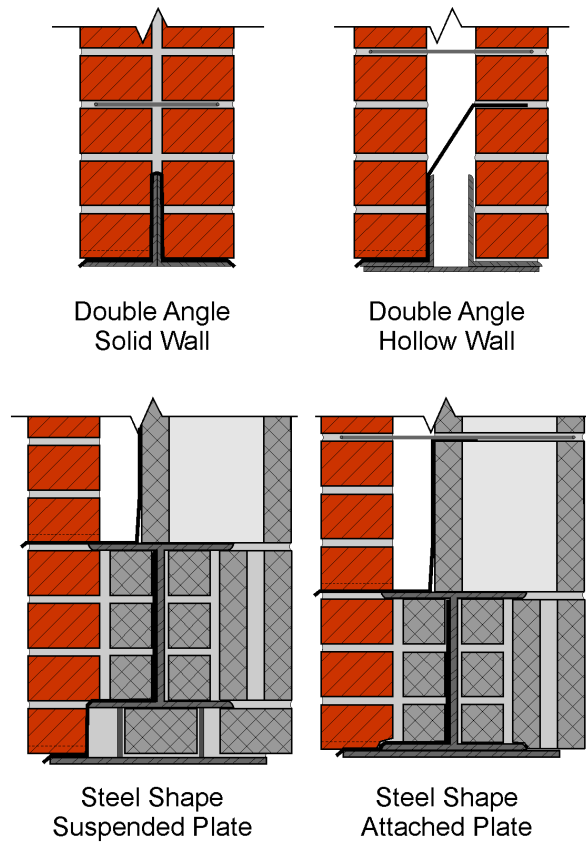


**Figure 15**  
Flanged Window Head Detail

Brickwork is allowed to project (corbel) from the face of the supporting member by a distance of up to one-half the nominal brick (unit) thickness. To achieve this, each course of the corbel is allowed to project the lesser of one-half the nominal brick (unit) height or one-third the nominal brick (unit) width. Where corbelled brickwork occurs below grade, adequate drainage should be provided below the brickwork (see [Figure 11a](#)). Where inadequate drainage is provided for such brickwork, frost heave may result if the brick shelf is located above the frost line.

**Window Sills.** Window sills integrated into brick construction should be sloped to shed water; a minimum slope of 15 deg from horizontal is recommended. Through-wall flashing must be placed under all sills, as shown in [Figure 12](#), [Figure 13](#) and [Figure 14](#), and turned up at the back and the ends to form a pan flashing. Soffits and deep reveals may require special flashing considerations. The *Technical Note 36 Series* contains further details and information.

**Steel Lintels.** Through-wall flashing is required at lintels over all openings including door and window heads, as shown in [Figure 15](#). Weeps are required immediately above the flashing. As indicated in the previous section, the flashing is turned up at each end of the lintel to form end dams. [Figure 16](#) shows several examples of lintels, including those anchored to structural steel members. Depending on the configuration of the structural steel member, the steel may interrupt the cavity, which requires installation of flashing on the top flange. However, this configuration leaves the beam web and top surface of the bottom flange susceptible to corrosion. In those cases,

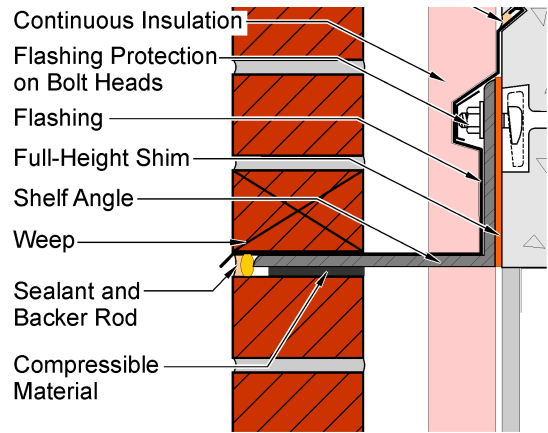


**Figure 16**  
**Structural Steel Lintels**

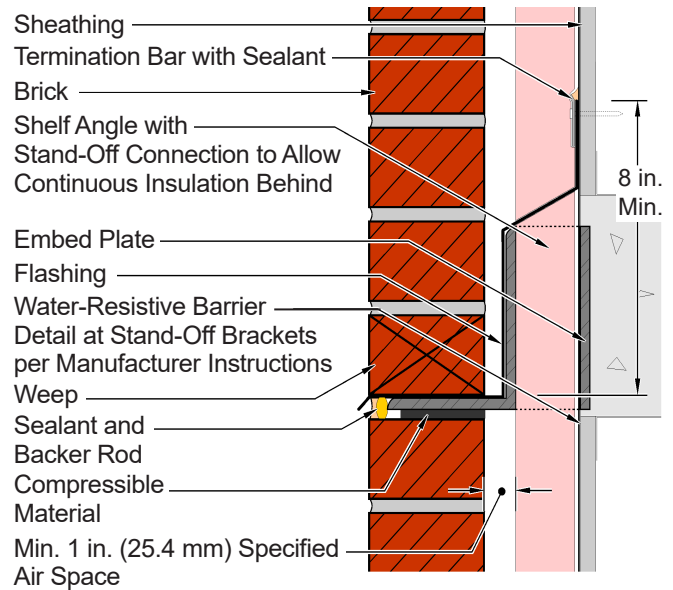
it is recommended to apply a protective coating to the steel and install an additional line of flashing at the lowest brick course. Typical shop primer or commercial paint is generally not adequate for this application.

**Shelf Angles.** In concrete or steel frame buildings with the brick wythe supported on shelf angles, the entire face of the spandrel beam may be flashed, or the flashing may be held in place by a termination bar installed on the spandrel beam or integrated with moisture-proofing on the spandrel beam. In some cases, shelf angle connections may cut, puncture or otherwise interrupt the flashing. When this occurs, it is important to make sure that all openings in the flashing are tightly sealed and that the flashing is attached to these supports with compatible sealant or adhesive. Refer to [Figure 17](#) and [Figure 18](#). Horizontal expansion joints are required beneath shelf angles to allow for movement of the brick. For further information on expansion joints, refer to the *Technical Note 18 Series*.

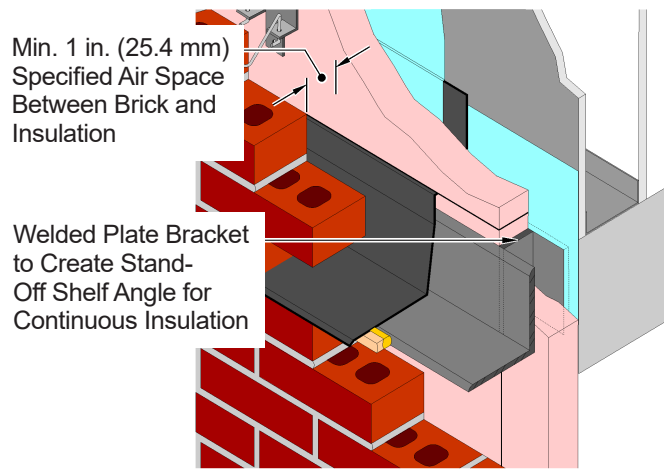
**Projections, Recesses and Caps.** Projections, recesses and caps tend to collect rainwater and



**Figure 17**  
**Shelf Angle with Concrete Frame**

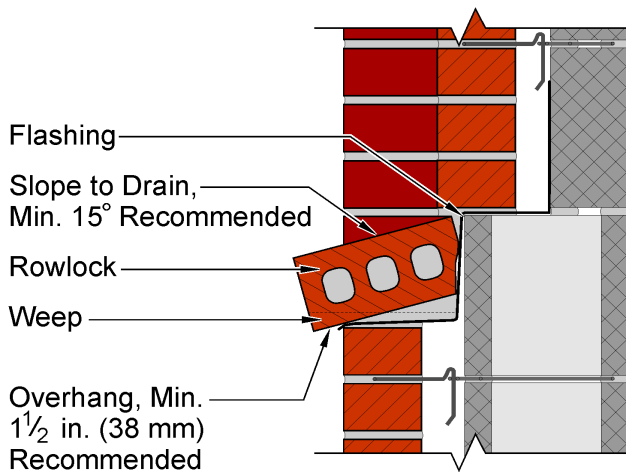
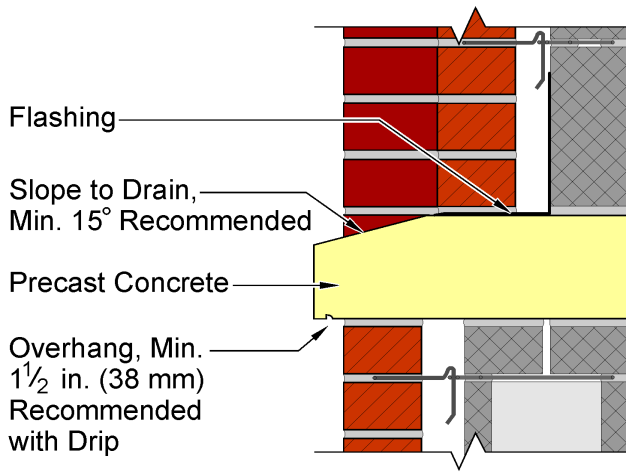


(a)

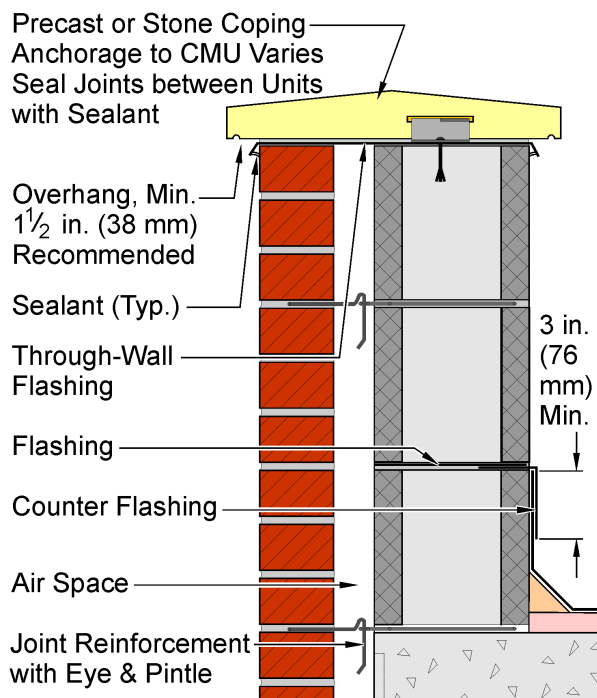


(b)

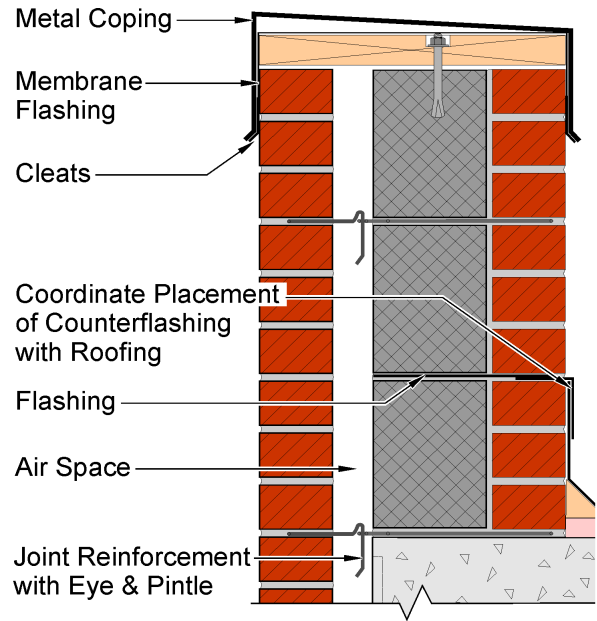
**Figure 18**  
**Shelf Angle with Stand-Off Attachment**



**Figure 19**  
Projections and Caps



**Figure 20**  
Precast or Stone Coping on Cavity Wall Parapet



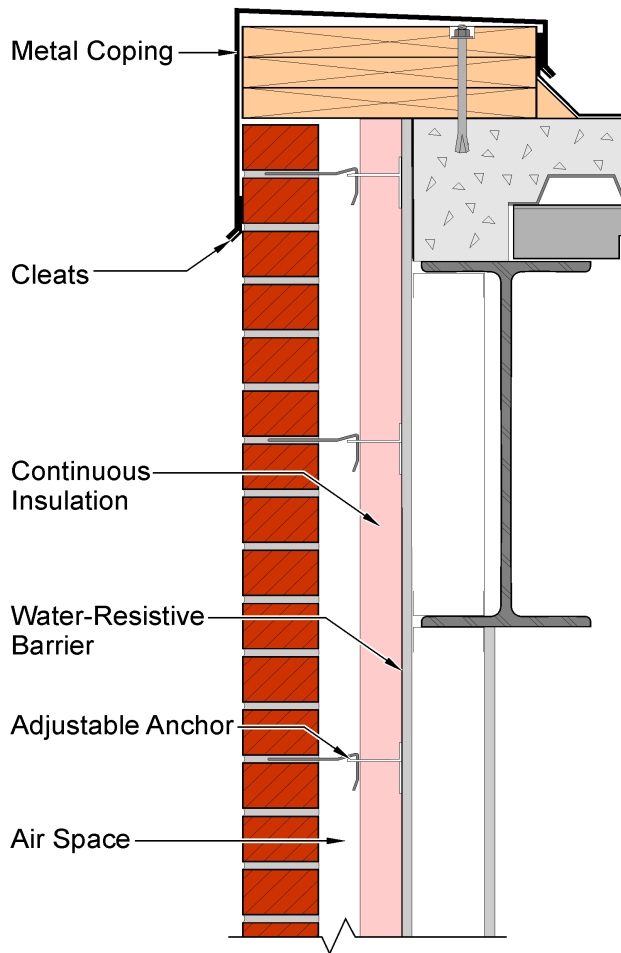
**Figure 21**  
Metal Coping on Cavity Wall Parapet

snow. They should be sloped away from the wall to drain and should be flashed where possible, similar to sill conditions, as shown in [Figure 19](#). Other details and information can be found in the *Technical Note 36 Series*.

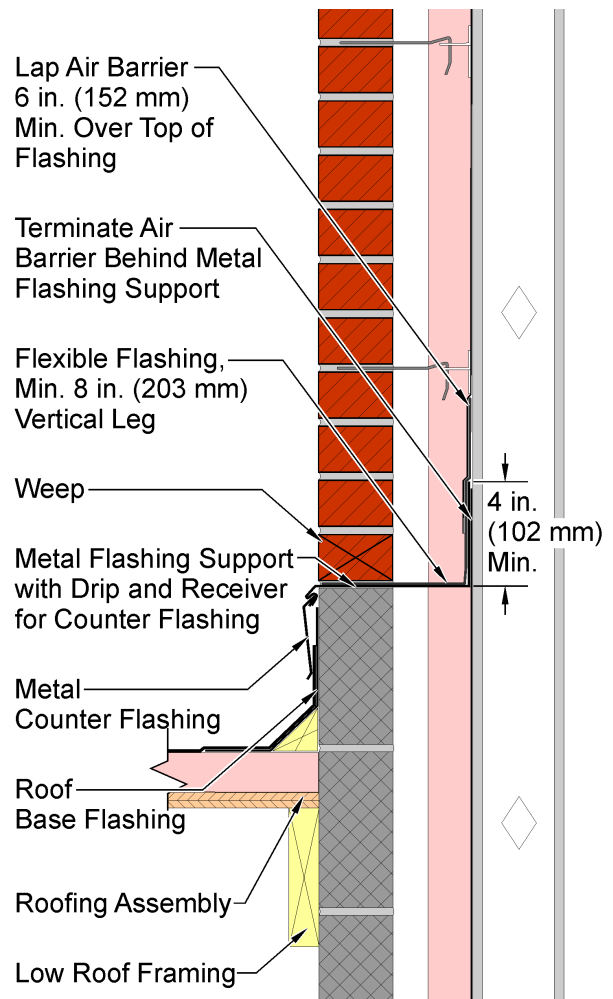
**Tops of Walls and Parapets.** The tops of all walls and parapets must have a cap or coping, with flashing recommended directly beneath the coping. Drainage-type parapet walls, as shown in [Figure 20](#) and [Figure 21](#), are recommended as the best parapet system for resistance to water penetration. The *Technical Note 36 Series* provides more details and information on these subjects.

For more effective moisture resistance, metal copings, as shown in [Figure 21](#) and [Figure 22](#), are preferable to brick, cast stone, concrete or stone copings. Metal copings should extend down the face of the wall a minimum of two courses, with the bottom edges anchored using concealed cleats designed to resist wind loads. Flexible membrane flashing should be installed continuously below the coping to protect the blocking and the top of the wall. A membrane formulated for high-temperature use is necessary under metal copings. Copings of cast stone, concrete or stone are recommended to have joints between each element closed with sealants, or with skyward-facing mortar joints raked to permit the installation of sealant at the outer surface.

**Roof/Wall Intersection.** Flashing placed at the intersection of a low roof with a wall or a roof deck with a parapet is critical to resist water penetration.

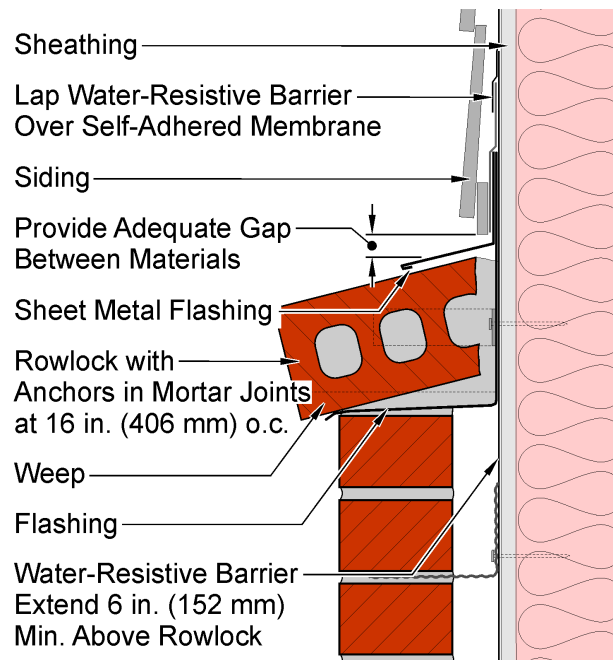


**Figure 22**  
Metal Coping on Non-Parapet Wall

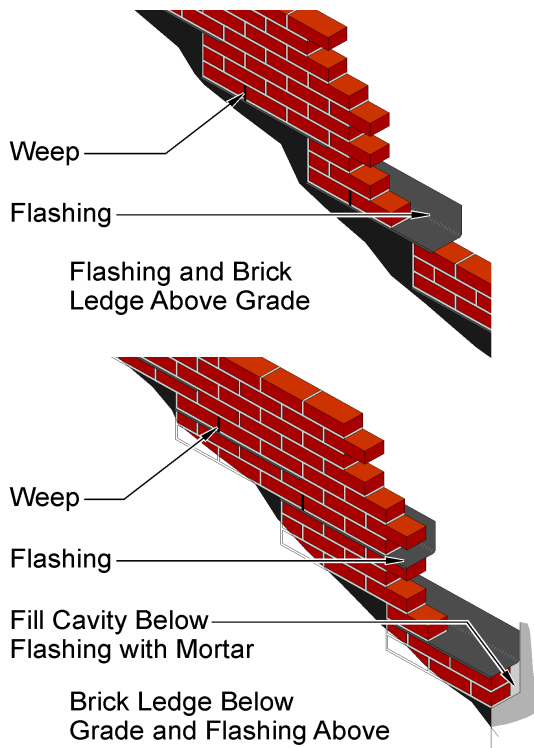


**Figure 23**  
Wall/Roof Intersection

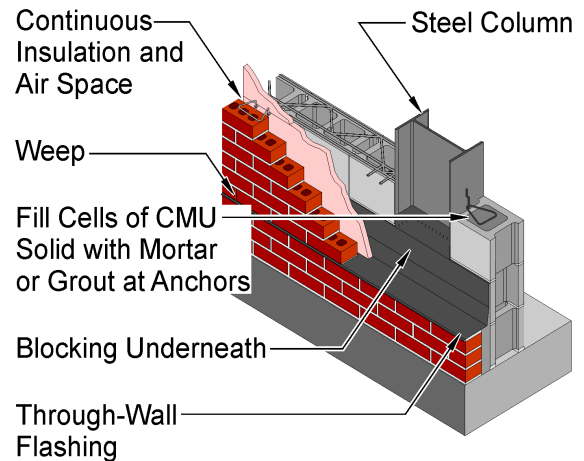
Depending on the type of wall, both through-wall flashing and counter flashing may be required. Counter flashing is used to protect the top edge of roof flashing that extends up the face of the brick. Generally, counter flashing is metal and overlaps roof flashing a minimum of 3 in. (76 mm). Coordination between the masonry and roofing trades is critical in order for the counter flashing to be installed in the masonry in the appropriate brick course. For a barrier wall, place counter flashing in the bed joint above the top of the roof flashing. Refer to [Figure 20](#) and [Figure 21](#). For a drainage wall with brick veneer, through-wall and counter flashing are required at the course above the top of the roof flashing. Install through-wall flashing that extends through the brick veneer, across the air space and turns up a minimum of 8 in. (203 mm). If flexible flashing is used, install a corrosion-resistant sheet metal support across the air space and extend up 4 in. (102 mm) minimum on the backing. Refer to [Figure 23](#). Under the through-wall flashing, provide counter flashing that extends down the face of the brick. If a metal drip edge is used for



**Figure 24**  
Brick Veneer/Siding Transition



**Figure 25**  
Stepped Flashing at Grade



**Figure 26**  
Flashing at Steel Column

the through-wall flashing, it can be fabricated to receive and anchor the counter flashing. Where roof line adjacent to wall is sloped, provide stepped flashing similar to [Figure 25](#). The counter flashing will also be stepped.

**Transitions with Other Materials.** Frequently, brick is used in combination with other cladding materials on the same facade, some of which may be barrier-style systems or have drainage cavities that are smaller than those for brick masonry. In these cases, the brick should be constructed to be self-contained. For instance, when transitioning to a non-masonry cladding above brick, there should be a cap element to cover the top of the masonry air space and a horizontal veneer expansion joint or gap to allow for the initial moisture expansion of the brick. See [Figure 24](#). When transitioning from brick to another material below that is not a masonry veneer, it should be treated as a wall base condition. When transitioning to the side, end dams should be installed at the flashing lines and closure brick installed along the full height of the transition.

**Vertical Changes in Direction.** In cases such as a sloped grade parallel to the building, stairs, retaining walls, loading docks or adjacent shelf angles, the flashing needs to account for these changes in direction. Stepped flashing is recommended for these conditions, as well as when the brick masonry surrounds a curved or sloped wall opening. See [Figure 25](#). Rather than installing a single piece of flashing laid flat, installing several layers of flashing not in the same course of brickwork can protect the wall against moisture penetration around the opening or sloped surface. To form a step, the end of the flashing at the highest elevation should be turned up to form an end dam with the opposite end laid flat. It is recommended that stepped flashing in higher courses of brickwork overlap the layer below by 4 in. (102 mm) minimum. The lowest piece of flashing should form a pan with end dams at both ends. Weeps to direct water out of the wall should be installed at each level of the stepped flashing. Alternatively, a series of tray flashings with end dams on both sides can be used.

**Balconies, Decks and Terraces.** Horizontal structural elements such as balconies and terraces interrupt the drainage plane of the brick masonry and should have a wall base flashing detail installed along the full length of the balcony, deck or terrace, with end dams installed at the ends. Additional end dams are required at the jambs to the access doors. The wall base detail is not required at the door, but a sill flashing is recommended. In some designs, there may be balcony waterproofing, either on the surface or below a topping slab. The vertical termination of the balcony waterproofing will coincide with the location of the masonry wall base flashing and should be coordinated to integrate the two systems for a watertight condition.

For residential applications, the *IRC* [Ref. 5] states that deck ledgers shall not be supported on masonry veneer. In order to support a deck on an exterior wall with brick veneer, the brick in the area of the attachment must be removed and the deck framing attached to the underlying house structure. Consequently, the brick veneer above the deck will require support and flashing around the ledger. A freestanding deck not attached to the exterior wall of the house is the recommended solution for this situation. Alternatively, there are a few manufactured brackets that, when installed, provide mounting surfaces located outside the exterior face of the brick, allowing the brick veneer to be installed in the typical manner. The brackets are detailed and waterproofed at the plane of the sheathing, similar to other projections.

**Steel Columns.** When the inside wythe of a cavity wall spans between steel columns and the column flanges are perpendicular to the masonry, special flashing detailing is required. **Figure 26** illustrates one way that this condition can be addressed. The flashing is formed into a tray and adhered to the column. The flashing must be supported across this area; brick or concrete masonry units may be placed at the column base to provide support. Alternatively, in cases where the flashing terminates on the vertical surface of the inner masonry wythe, sheet metal can be used to span the column flanges, permitting the vertical leg of the flashing to continue in the typical manner. This sheet metal closure would require a tray or sloped top surface extending to the column web and a sealed perimeter to prevent moisture from undermining the flashing.

## SUMMARY

Masonry walls constructed of brickwork have performed well for centuries and are a testament to the performance and durability of brick. Design and detailing that maximizes the water penetration resistance of brickwork is needed to achieve this level of service. Selection of the wall type should be based on the project's location, environmental conditions and building use. Water penetration resistance of brickwork is enhanced by including appropriate details that reduce water penetration at key points in the brickwork.

*The information and suggestions contained in this Technical Note are based on the available data and the combined experience of engineering staff and members of the Brick Industry Association. The information contained herein must be used in conjunction with good technical judgment and a basic understanding of the properties of brick masonry. Final decisions on the use of the information contained in this Technical Note are not within the purview of the Brick Industry Association and must rest with the project architect, engineer and owner.*

## REFERENCES

1. ASTM E2266, "Standard Guide for Design and Construction of Low-Rise Frame Building Wall Systems to Resist Water Intrusion," *Annual Book of Standards*, Vol. 04.12, ASTM International, West Conshohocken, PA, 2016.
2. *Building Code Requirements for Masonry Structures* (TMS 402), The Masonry Society, Longmont, CO, 2016.
3. Building Science Corporation, Westford, MA.  
Building Science Digest 012: Moisture Control for New Residential Buildings, March 2009.  
Building Science Digest 013: Rain Control in Buildings, August 2011.  
Building Science Digest 104: Understanding Air Barriers, October 2006.  
Building Science Digest 105: Understanding Drainage Planes, October 2006.  
Building Science Digest 106: Understanding Vapor Barriers, April 2011.  
Building Science Insights 001: The Perfect Wall, July 2010.  
Building Science Insights 084: Forty Years of Air Barriers – The Evolution of the Residential Air Barrier, February 2015.
4. *International Building Code*, International Code Council, Country Club Hills, IL, 2015.
5. *International Residential Code*, International Code Council, Country Club Hills, IL, 2015.