

Installation Requirements

4.1 Code Reference

The “authority having jurisdiction” should be referenced to determine what law, ordinance or code shall apply in the use of flexible duct.

Ducts conforming to NFPA 90A or 90B shall meet the following requirements:

- a. Shall be tested in accordance with Sections 7 to 23 of Underwriters Laboratories Standard for Factory-Made Air Ducts and Air Connectors, UL 181.
- b. Shall be installed in accordance with the conditions of their listing.
- c. Shall be installed within the limitations of the applicable NFPA 90A or 90B Standard.

4.2 Installation Restrictions and Use Limitations

There are specific restrictions and limitations related to the use of flexible ducts. Some are due to NFPA Standards, model codes and various state/local codes. Others are due to end use performance where the product was not designed for that specific use. Some, but not all inclusive, are as follows:

- a. Shall not be used for vertical risers serving more than two stories in height.
- b. Shall not be used in systems with entering air temperature higher than 250°F[121°C].
- c. Shall be installed in accordance with the conditions of their listing.
- d. When installed in a fire-rated floor/roof ceiling assembly, ducts shall conform with the design of the tested fire-resistive assembly.
- e. Shall be interrupted at the immediate area of operation of electric, fossil fuel or solar energy collection heat sources to meet listed equipment clearances specified.

- f. Air Connectors (does not apply to Air Ducts) shall not be installed in lengths greater than 14 ft. [4.3 m] for any given run; shall not pass through any wall, partition or enclosure of a vertical shaft with a 1 hour or more fire resistive rating; shall not pass through floors.
- g. Shall not penetrate walls where fire dampers are required.
- h. Shall not be used outdoors unless specifically designed to withstand exposure to direct sunlight and the weathering elements.
- i. Shall not be used to vent appliances for cooking, heating and clothes drying unless approved and recommended by the appliance manufacturer.
- j. Shall not be installed in concrete, buried below grade or in contact with the ground.

4.3 General

The routing of flexible duct, the number of bends, the degrees in each bend, and the amount of sag or direction changes (snaking) allowed between support joints will have serious effects on system performance due to the increased resistance each introduces (See Fig 6 & 7). Use the minimum length of flexible duct to make connections (See Section 4.5). Excess length of flexible duct shall not be installed to allow for possible future relocations of air terminal devices.

Avoid installations where exposure to direct sunlight can occur, e.g. turbine vents, sky lights, canopy windows, etc. Prolonged exposure to sunlight will cause degradation of the vapor barrier. Direct exposure to UV light from a source lamp installed within the HVAC system will cause degradation of some inner core/liner materials.

Terminal devices shall be supported independently of the flexible duct.

Repair torn or damaged vapor barrier/jacket with duct tape listed and labeled to Standard UL 181B. If internal core is penetrated, replace flexible duct or treat as a connection.

4.4 Installation and Usage

Install ducts fully extended. Do not install in the compressed state or use excess length as this will noticeably increase friction losses. (Refer to Section 4.5 for more specific information regarding pressure loss and duct sizing.)

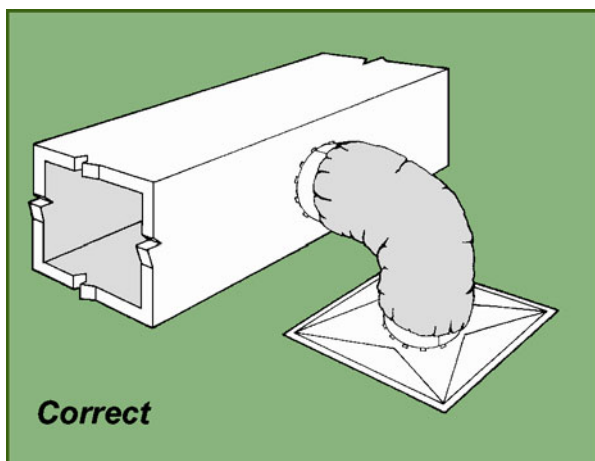

Figure 6 - Minimum duct length and bend radius reduces pressure drop and improves airflow.

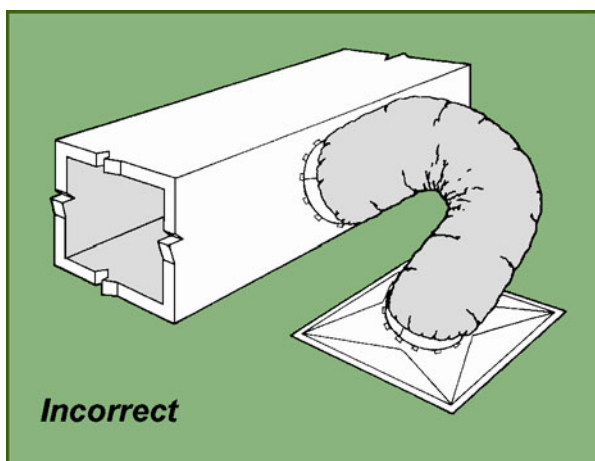

Figure 7 - Excess length and tight bend radius increases pressure drop and reduces airflow.

Do not bend ducts across a sharp corner of building materials such as joists or truss supports.

The bend radius at the center line of ducts shall be equal to or greater than one duct diameter (See Figures 8 and 11). Sharper bends increase pressure drop significantly and reduce airflow.

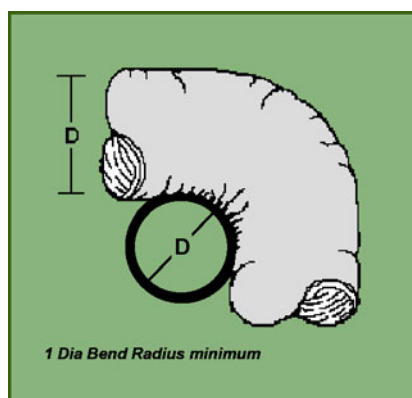

Figure 8 - Correct. Minimum 1 duct diameter bend radius reduces pressure drop and improves air flow.

Avoid incidental contact with metal fixtures, water lines, pipes, or conduits. Do not install near hot equipment (e.g. furnaces, boilers, steam pipes, etc.) that is above the recommended flexible duct use temperature.

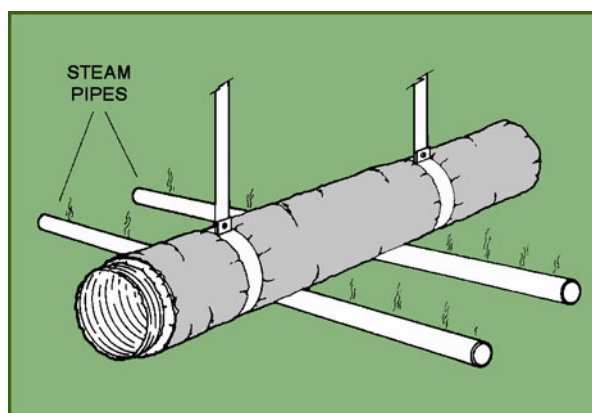

Figure 9 - Incorrect. Contact with steam pipes.

Installation Requirements . . . continued

4.5 Duct Sizing and Routing

The combined friction and dynamic pressure losses shall be taken into consideration to properly size any duct. Pressure losses caused by the roughness of the duct wall resisting air movement are known as friction losses. Pressure losses when air flow changes direction, as caused by bends or when air flows across other system components, are known as dynamic losses.

Key points to prevent undersizing or oversizing of flexible ducts and achieve the designed air delivery performance:

- a. Use a proven method of duct sizing, one that has taken into consideration both friction and dynamic losses.

Design the flexible duct system per the requirements of ACCA, Manual D (Residential) and Manual Q (Commercial).

Properly take into account duct length, bend losses, sagging or routing expectations, fitting losses, etc.

- b. Have a good understanding of and properly use the air friction chart.

Do not use data for round sheet metal duct.

Since all flexible ducts are not alike, use the flexible duct manufacturer's air friction loss data to size the ducts whenever possible.

If no data is available, use the generic flexible duct friction loss chart in ACCA Manual D.

- c. Use the minimum length of flexible duct needed to make the connections.

Install ducts extended to their fullest length without compression. Due to the helical configuration of flexible duct inner cores, excess longitudinal compression can dramatically affect the pressure drop.

If a flexible duct is not fully extended, the friction rate increases proportionally with the compression (See Fig. 10).

When a flexible duct is fully extended, it is said to have no more than 4% longitudinal compression and the published friction rate may be used for duct sizing calculations ($0 - 4\% = 1 \times \text{Friction Rate}$).

For 15% longitudinal compression the friction rate can increase by a factor of two ($15\% = 2 \times \text{Friction Rate}$).

For longitudinal compression of 30% the friction rate can increase as much as four times ($30\% = 4 \times \text{Friction Rate}$).

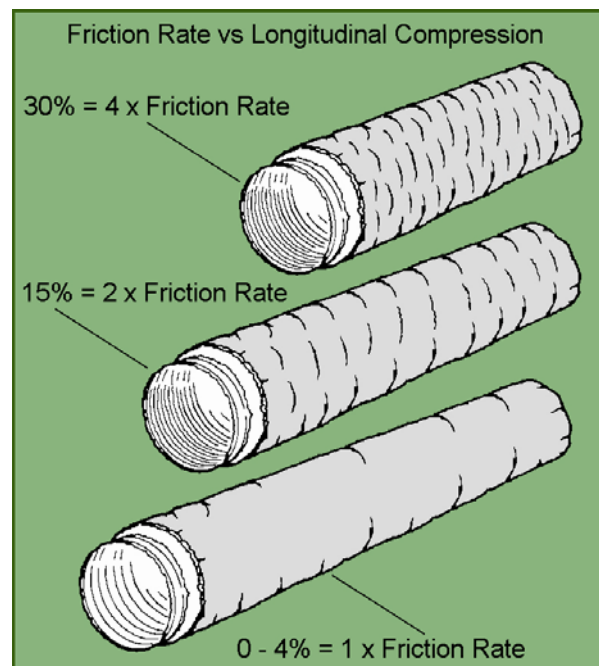

Figure 10 - Compressed duct (not fully extended) increases friction rate.

Installation Requirements . . . continued

- d. Keep bends greater than or equal to one (1) duct diameter bend radius.

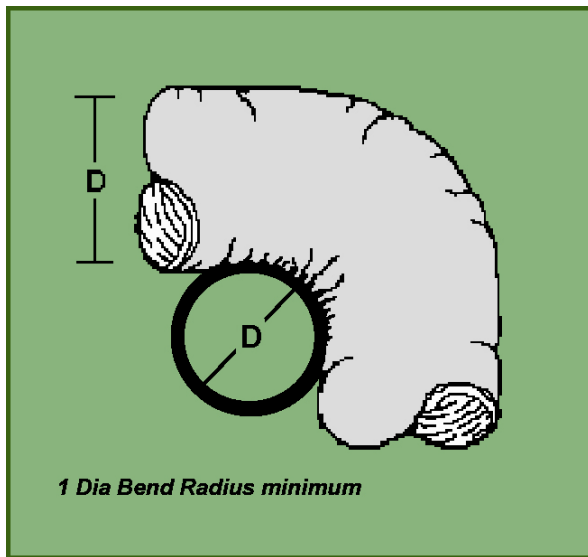

Figure 11

- e. Properly route and support the flexible duct runs.

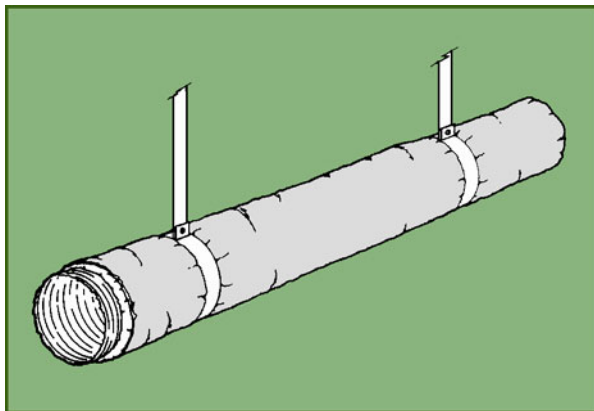

Figure 12

Care shall be taken to minimize sagging or snaking of the duct between supports and minimize pressure loss caused by excessive direction changes to the airflow.

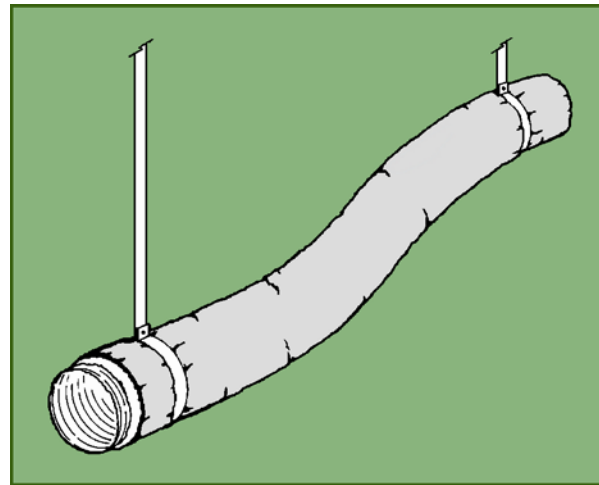

Figure 13

Ducts shall not be crimped against joist or truss members, pipes, wires, etc. as this increases pressure loss and reduces air flow.

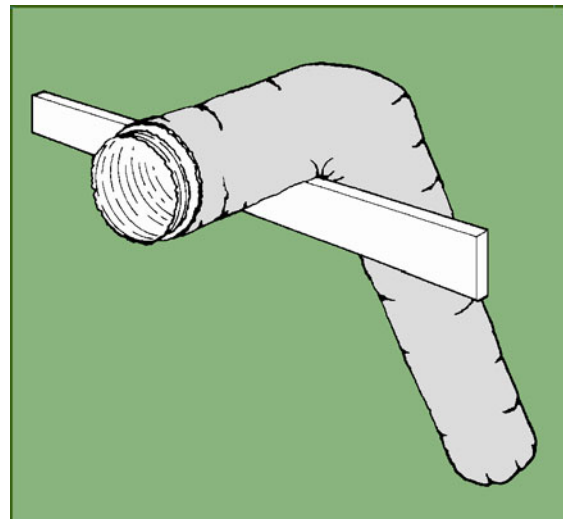

Figure 14

Installation Requirements . . . continued

- f. Properly account for bends in the duct runs.

A 90-degree bend has pressure drop equal to approximately twenty (20) lineal feet of flexible duct. So each 90-degree bend will add twenty (20) equivalent feet to the length used for sizing calculations.

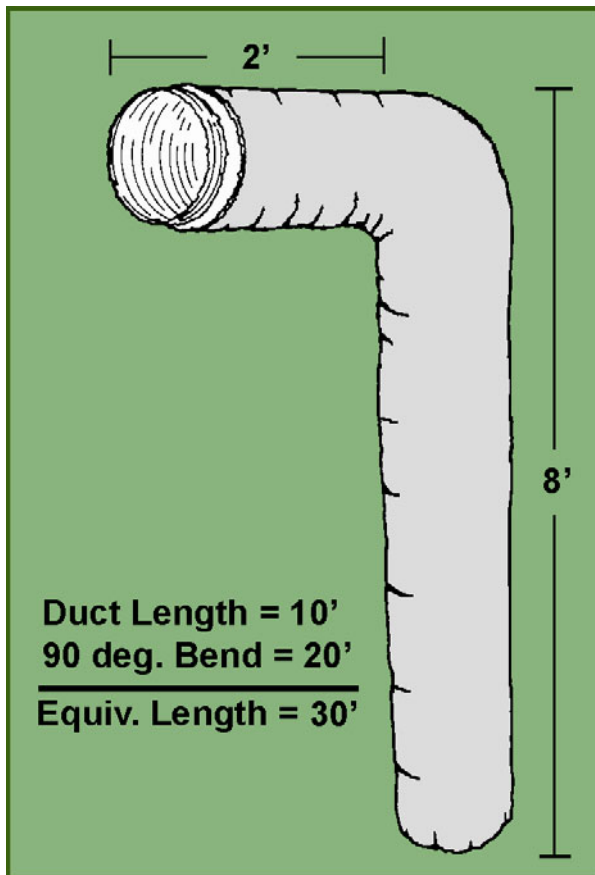

Figure 15

A gradual 45-degree bend has pressure drop equal to about ten (10) lineal feet of flexible duct. Add ten (10) equivalent feet to the length for each gradual bend (see Fig. 16).

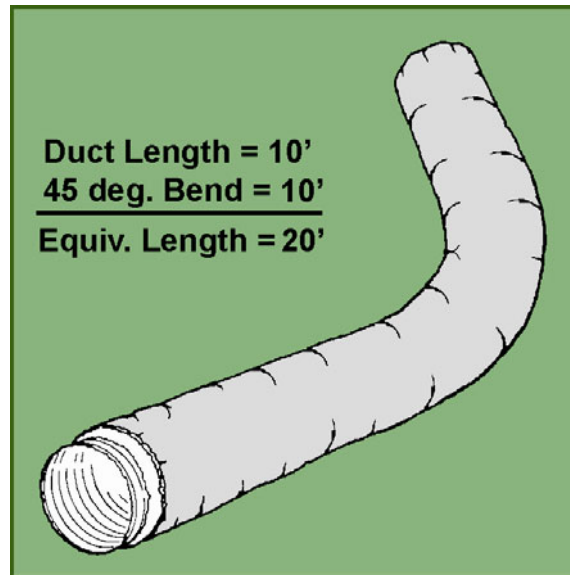

Figure 16

A 180-degree offset has pressure drop equal to about forty (40) lineal feet of flexible duct. Add forty (40) equivalent feet to the length for each sharp 180-degree offset.

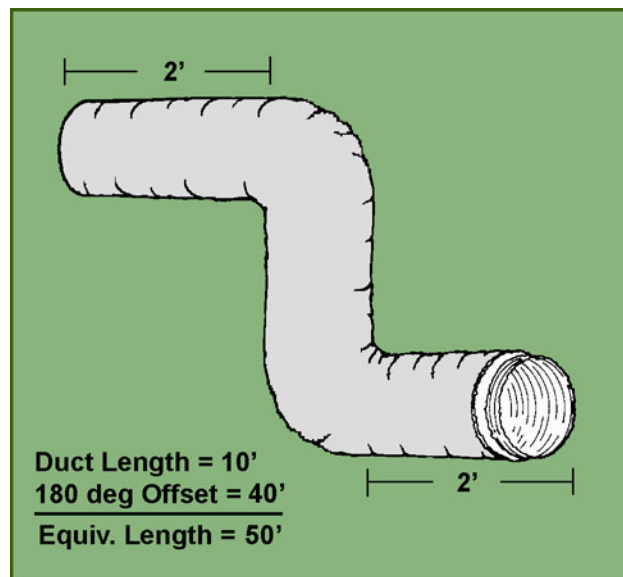

Figure 17

Installation Requirements . . . continued

Duct fittings and any bends and turns in flexible duct all produce a resistance to airflow. This resistance creates a pressure drop measured in inches water column (IWC) which is physically equivalent to the pressure drop produced by a straight section of duct. So the total pressure drop for any duct run equals the sum of the fitting pressure drops and the pressure drop of the straight duct section.

To determine the correct duct size, take into account the total equivalent length of the duct run, including entrance and exit losses from the plenum to the duct and from the duct into the terminal device, the added length due to any bends, and the total length of the duct itself.

Use ACCA Manual D (App. 3) equivalent length values for bends and fittings.

A typical duct run from plenum to terminal device is illustrated in Figure 18.

The worksheet for determining the total pressure drop of the duct run depicted in Figure 18 will look like this:

Entrance fitting =	35 ft.
Total duct length =	14 ft.
2 x 45° bends (2 x 10') =	20 ft.
1 x 90° bend (1 x 20') =	20 ft.
Exit fitting =	35 ft.

Total Equivalent Length = 124 ft.

Although the distance from plenum to terminal end in this example is approximately 12 feet, the total equivalent length used to determine the correct duct diameter would be 124 feet.

The equivalent length values for bends & fittings represented above are default values from ACCA Manual D and based on 900 fpm at 0.08 IWC/100' for supply ducts and 700 fpm at 0.08 IWC/100' for return ducts.

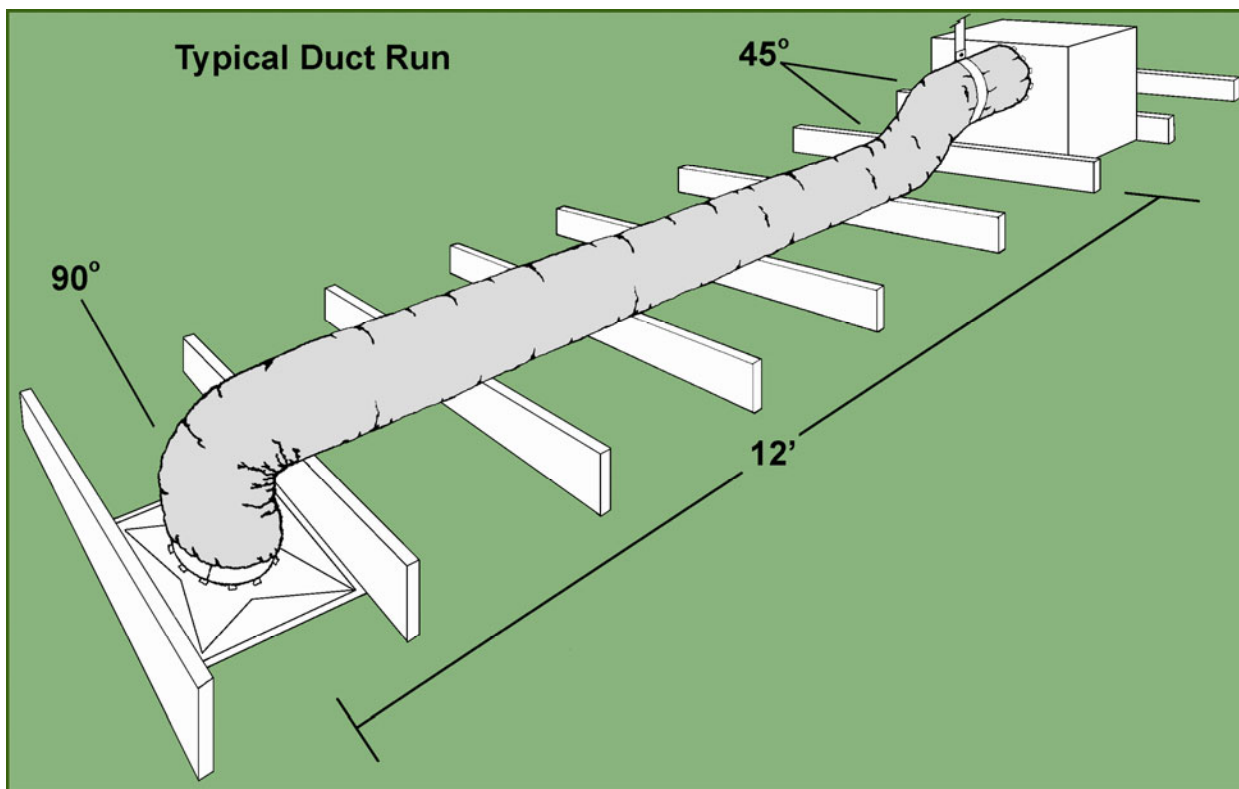

Figure 18

Installation Requirements . . . continued

4.6 Supporting Flexible Duct

Flexible duct shall be supported at manufacturer's recommended intervals, but at no greater distance than 4' [1.2 m]. Supporting shall be provided so that the maximum centerline sag is 1/2" per foot [42 mm per meter] of spacing between supports (See Fig 19). A connection to rigid duct or equipment may be considered a support joint.

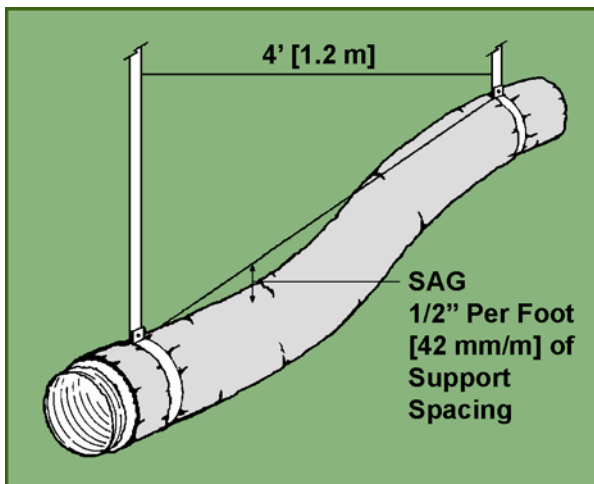

Figure 19

Long horizontal duct runs with sharp bends shall have additional supports before and after the bend approximately one duct diameter from the center line of the bend (See Fig 20).

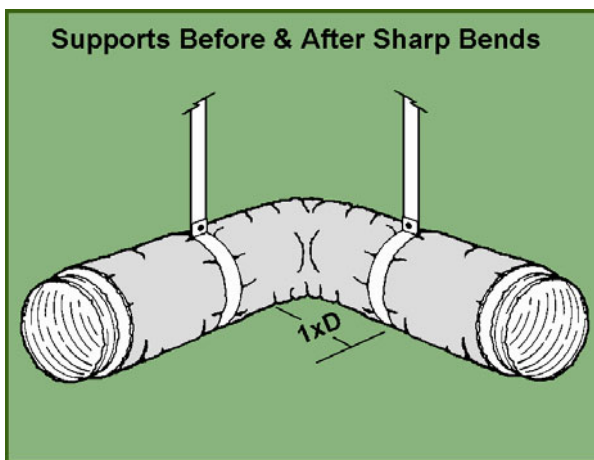

Figure 20

Hanger or saddle material in contact with the flexible duct shall be of sufficient width to prevent any restriction of the internal diameter of the duct when the weight of the supported section rests on the hanger or saddle material. In no case will the material contacting the flexible duct be less than 1 1/2" [38 mm] wide (See Fig 21).

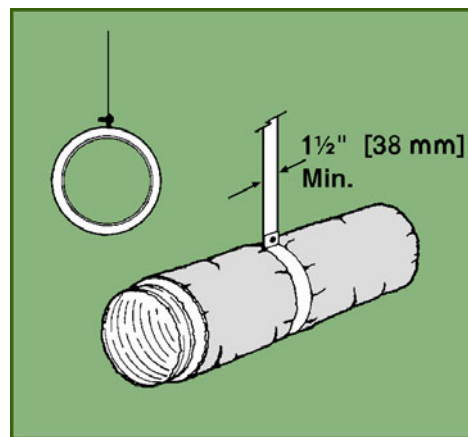

Figure 21

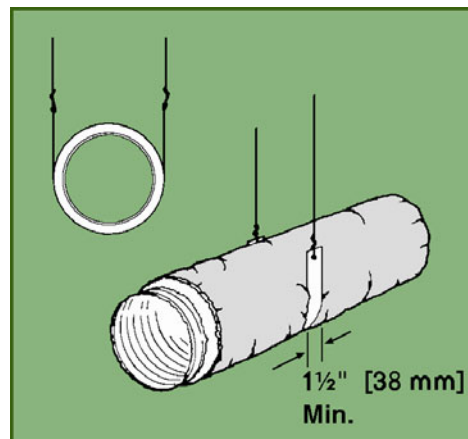

Figure 22

Do not secure support straps in a manner that compresses the inner core and constricts the air flow. Care shall be taken to insure the vapor barrier and insulation material are not excessively compressed by the support straps. Compressing the insulation could lead to condensation at the point of contact between the duct and the strap or saddle material.

Installation Requirements . . . continued

Factory installed suspension systems integral to the flexible duct are an acceptable alternative hanging method when manufacturer's recommended procedures are followed.

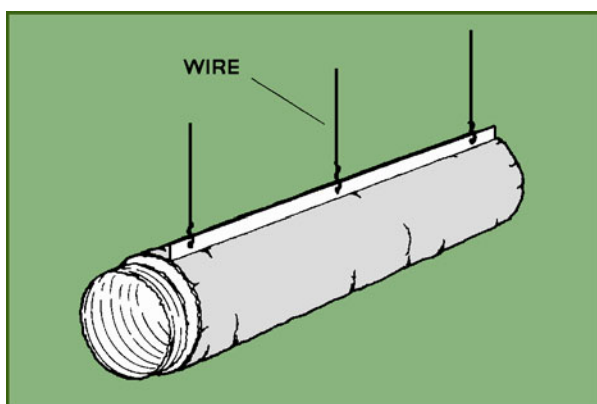

Figure 23

Support the duct between a metal connection and bend by allowing the duct to extend straight for at least one duct diameter before making the bend. This will avoid possible damage of the flexible duct by the edge of the metal collar and allow for efficient air flow and fitting performance (See Fig 25).

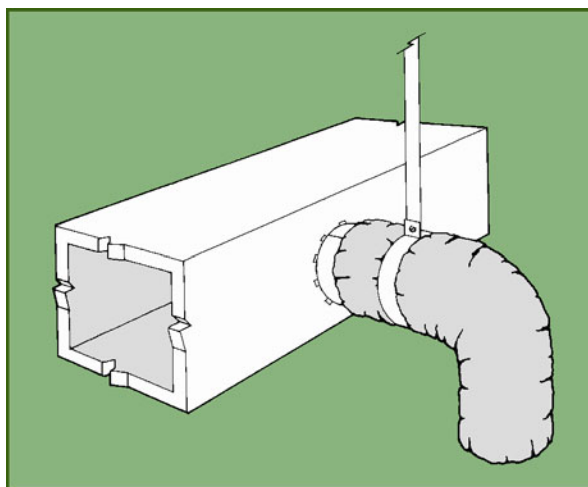

Figure 25

Flexible ducts may rest on ceiling joists or truss supports. Maximum spacing between supports shall not exceed the maximum spacing per manufacturer's installation instruction.

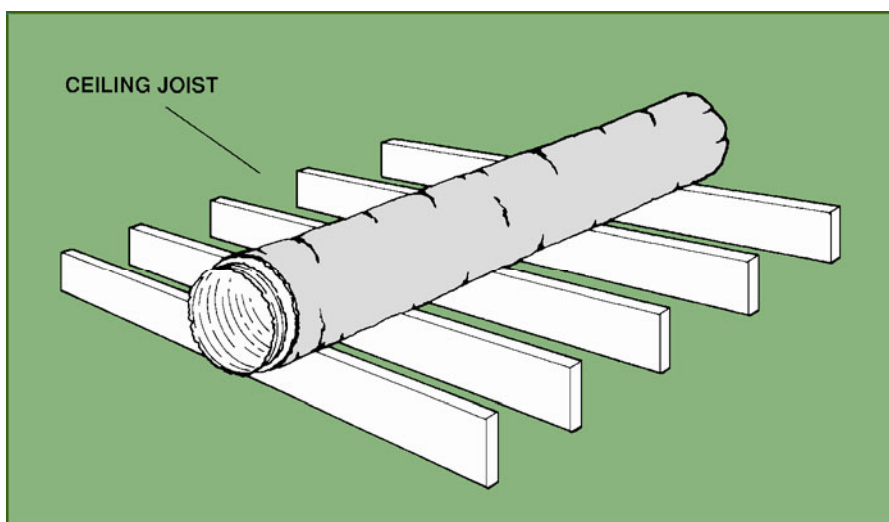

Figure 24

Note:

Factory-made air ducts may not be used for vertical risers in air duct systems serving more than two adjacent stories.

Vertically installed ducts shall be stabilized by support straps at a max. of 6' [1.8 m] on center.

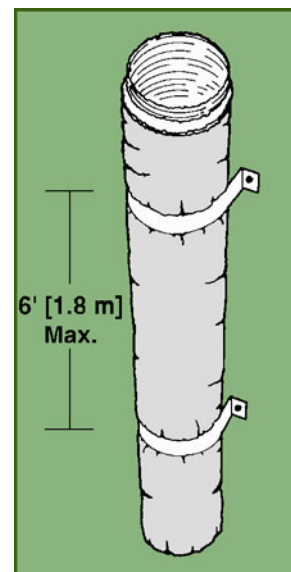

Figure 26

Installation Requirements . . . continued

4.7 Connecting, Joining and Splicing Flexible Ducts

All connections, joints and splices shall be made in accordance with the manufacturer's installation instructions.

Standardized installation instructions conforming to the connecting and sealing requirements of the national building codes and this standard are shown in Sections 4.7.1 through 4.7.3.

Section 4.7.1 - "Installation Instructions for Air Ducts and Air Connectors - Nonmetallic With Plain Ends" (uses tape and clamp to seal and secure the duct core to the fitting).

Section 4.7.2 - "Alternate Installation Instructions for Air Ducts and Air Connectors - Nonmetallic With Plain Ends" (uses mastic and clamp to seal and secure the duct core to the fitting).

Section 4.7.3 - "Installation Instructions for Air Ducts and Air Connectors - Metallic With Plain Ends (optional use of tape or mastic and metal screws to seal and secure the duct core to the fitting).

Due to the wide variety of ducts and duct assemblies with special end treatments (factory installed fittings, taped ends, crimped metal ends, etc.), only these standardized installation instructions are shown. Always reference the manufacturer's installation instructions for more detailed requirements.

All tapes, mastics, and nonmetallic clamps used for field installation of flexible ducts shall be listed and labeled to Standard UL 181B - Closure Systems for Use With Flexible Air Ducts and Air Connectors.

Sheet metal fittings to which flexible ducts with plain ends are attached shall be beaded and have a minimum of 2 inches [50 mm] collar length. Beads are optional for fittings when using metal worm-gear clamps or when attaching *metallic* flexible ducts using sheet metal screws.

Sheet metal sleeves used for joining two sections of flexible duct with plain ends shall be a minimum of 4 inches [100 mm] in length and beaded on each end. Beads are optional for sleeves when using metal worm-gear clamps or when joining *metallic* flexible ducts using sheet metal screws.

Flexible ducts secured with nonmetallic clamps shall be limited to 6 inches w.g. [1500 Pa] positive pressure.

Installation Requirements . . . continued

4.7.1 Installation Instructions for Air Ducts and Air Connectors - Nonmetallic with Plain Ends

Connections - Using Tape and Fasteners

1. After desired length is determined, cut completely around and through duct with knife or scissors. Cut wire with wire cutters. Fold back jacket and insulation.

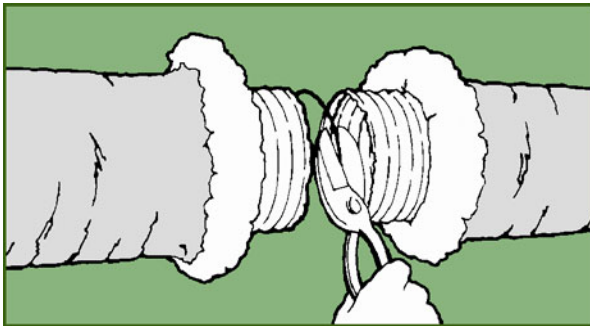

2. Slide at least 1" [25 mm] of core over fitting and past the bead. Seal core to collar with at least 2 wraps of duct tape. Secure connection with clamp placed over the core and tape and past the bead.

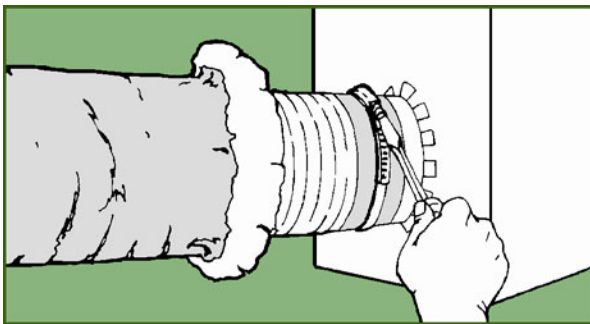

3. Pull jacket and insulation back over core. Tape jacket with at least 2 wraps of duct tape. A clamp may be used in place of or in combination with the duct tape.

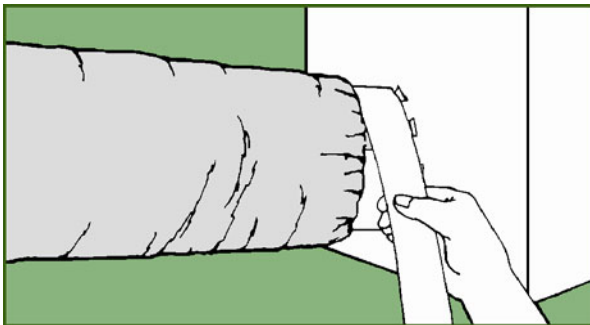

Splices - Using Tape and Fasteners

1. Fold back jacket and insulation from core. Butt two cores together on a 4" [100 mm] min. length metal sleeve.

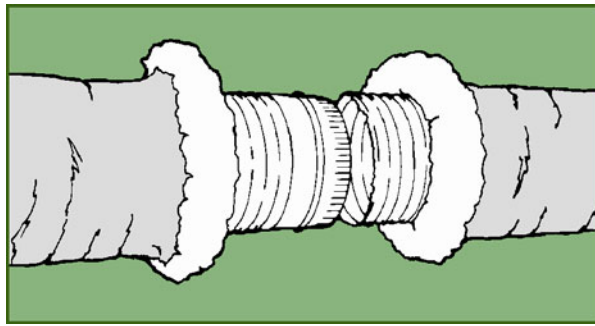

2. Tape cores together with at least 2 wraps of duct tape. Secure connection with 2 clamps placed over the taped core ends and past the beads.

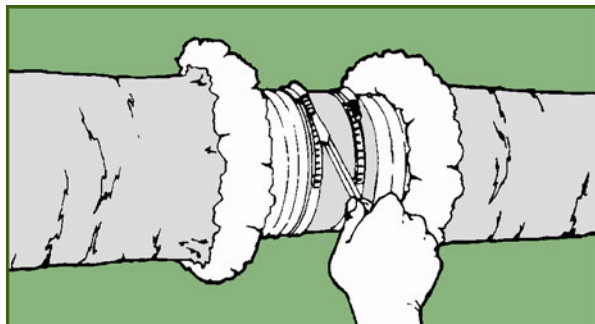

3. Pull jacket and insulation back over cores. Tape jackets together with at least 2 wraps of duct tape.

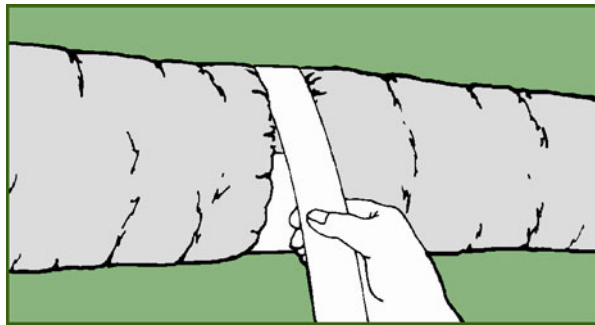

NOTES:

1. For uninsulated air ducts and air connectors, disregard references to insulation and jacket.
2. Use beaded sheet metal fittings and sleeves when using nonmetallic clamps.
3. Use tapes listed and labeled in accordance with Standard UL 181B and marked "181B-FX".
4. Nonmetallic clamps shall be listed and labeled in accordance with Standard UL 181B and marked "181B-C". Use of nonmetallic clamps shall be limited to 6 in. w.g. [1500 Pa] positive pressure.

Installation Requirements . . . continued

4.7.2 Alternate Installation Instructions for Air Ducts and Air Connectors - Nonmetallic with Plain Ends

Connections and Splices - Using Mastic and Fasteners

Step 1

After desired length is determined, cut completely around and through duct with knife or scissors. Cut wire with wire cutters. Pull back jacket and insulation from core.

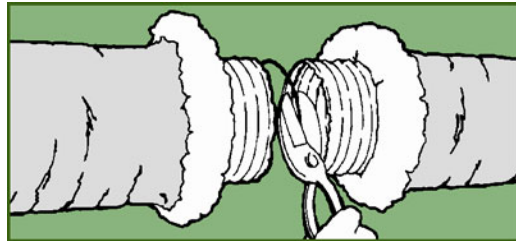

Step 2

Apply mastic approximately 2" [50 mm] wide uniformly around the collar of the metal fitting or over the ends of a 4" [100 mm] min. length metal sleeve. Reference data on mastic container for application rate, application thickness, cure times and handling information.

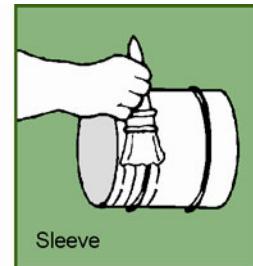
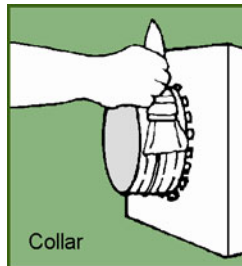

Step 3

Slide at least 2" [50 mm] of core over the fitting or sleeve ends and past the bead.

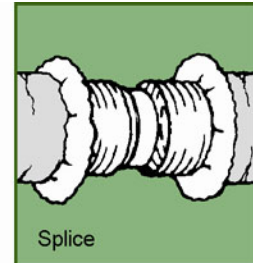
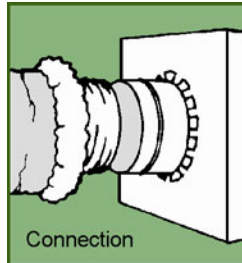

Step 4

Secure core to collar with a clamp applied past the bead. Secure cores to sleeve ends with 2 clamps applied past the beads.

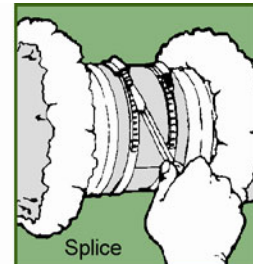
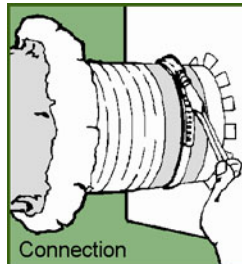

Step 5

Pull jacket and insulation back over core ends. Tape jacket(s) with at least 2 wraps of duct tape. A clamp may be used in place of or in combination with the duct tape.

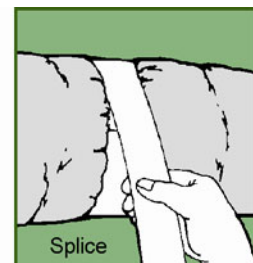
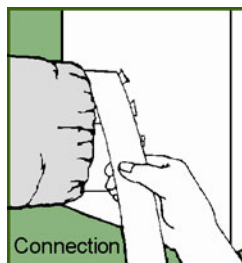

NOTES:

1. For uninsulated air ducts and air connectors, disregard references to insulation and jacket.
2. Use beaded sheet metal fittings and sleeves when using nonmetallic clamps.
3. Use mastics listed and labeled in accordance with Standard UL 181B and marked "181B-M" on container.
4. Use tapes listed and labeled in accordance with Standard UL 181B and marked "181B-FX".
5. Nonmetallic clamps shall be listed and labeled in accordance with standard UL 181B and marked "181B-C". Use of nonmetallic clamps shall be limited to 6 in. w.g. [1500 Pa] positive pressure.

Installation Requirements . . . continued

4.7.3 Installation Instruction for Air Ducts and Air Connectors - Metallic with Plain Ends

Connections and Splices - Using Tape or Mastic and Sheet Metal Screws

1. After cutting duct to desired length, fold back jacket and insulation exposing core. Trim core ends squarely using suitable metal shears. Determine optional sealing method (Steps 2 or 5) before proceeding.

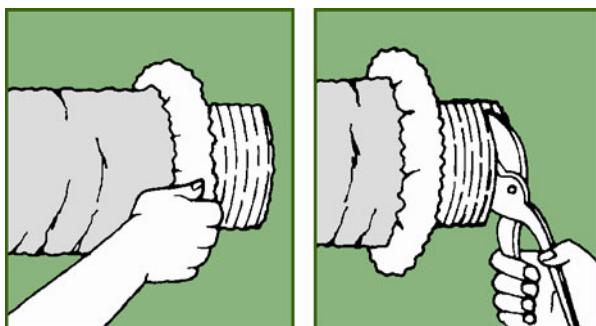

4. Secure to collar/sleeve using #8 sheet metal screws spaced equally around circumference. Use 3 screws for diameters under 12" [300 mm] and 5 screws for diameters 12" [300 mm] and over.

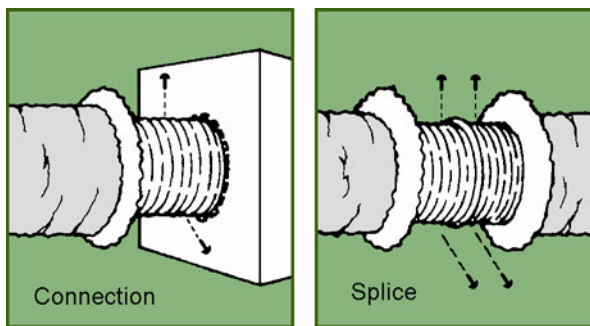

2. When mastics are required and for pressures 4" w.g. [1000 Pa] and over, seal joint with mastic applied uniformly to the outside surface of collar/sleeve. (Disregard this step when not using mastics and proceed to Step 3).

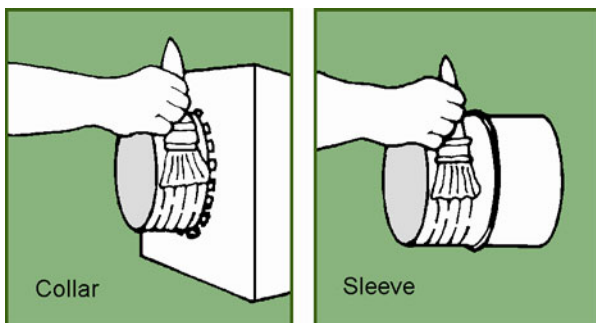

5. For pressures under 4" w.g. [1000 Pa] seal joint using 2 wraps of duct tape applied over screw heads and spirally lapping tape to collar/sleeve. (Disregard this step when using mastics per Step 2).

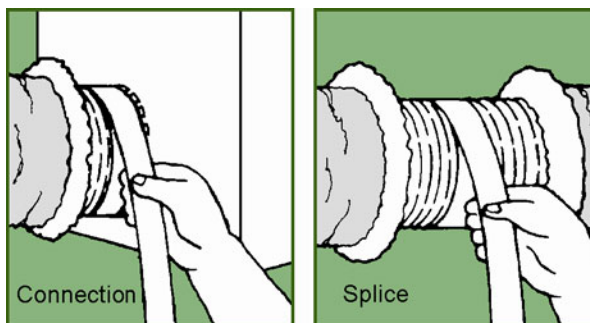

3. Slide at least 1" [25 mm] of core over metal collar for attaching duct to take off or over ends of a 4" [100 mm] metal sleeve for splicing 2 lengths of duct.

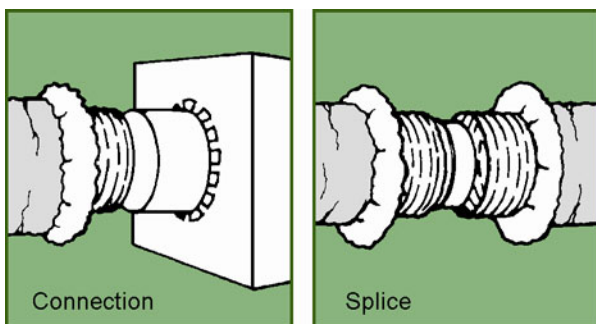

6. Pull jacket and insulation back over core. Tape jacket with 2 wraps of duct tape. A clamp may be used in place of or in combination with the duct tape.

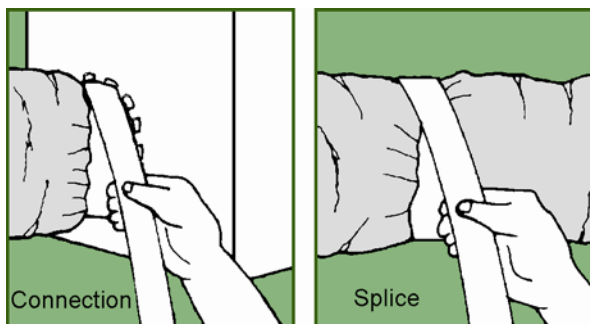

NOTES:

1. For uninsulated air ducts and air connectors, disregard references to insulation and jacket.
2. Use mastics listed and labeled to Standard UL 181B and marked "181B-M" on container.
3. Use tapes listed and labeled to Standard UL 181B and marked "181B-FX".
4. Nonmetallic clamps shall be listed and labeled in accordance with Standard UL 181B and marked "181B-C".