

**NAMIC**<sup>®</sup>  
NATIONAL ASSOCIATION OF MUTUAL INSURANCE COMPANIES

# *woodburning stoves*

*"Woody the Woodburner"*

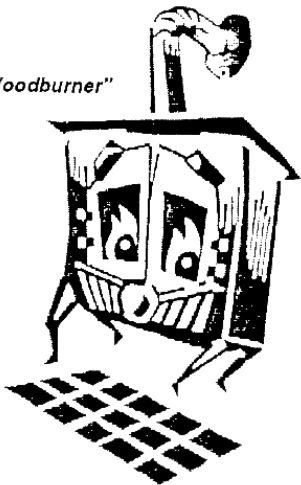

installation and procedures

REVISED AUGUST, 2006  
CONFORMS TO NFPA 211-2006

## **Legal Disclaimer**

The information contained herein is not intended to be used as a guide for installation or operation of any solid or liquid fuel heating device. Use of this information is at your own risk. Please refer to your local or state building codes for installation and operational compliance.

*"Woody the Woodburner"*

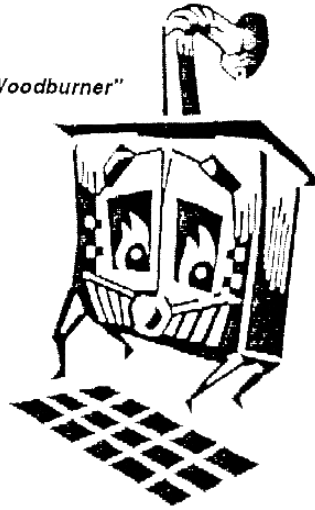

# Woodburning Stoves

## BEFORE YOU BUY A WOODSTOVE

### KNOW THAT:

- 1. Woodburning stoves are not to be installed in residential garages or where there is a likelihood of fuel vapors. This may also include service or utility buildings such as machine sheds or workshops.*
- 2. There are special requirements for the use of Woodburning stoves in mobile homes. The appliance must be listed for use in mobile homes.*
- 3. Do it yourself installations are not always the best. Consider employing a qualified professional.*

Make sure the stove is listed by Underwriters Laboratories or a similar nationally recognized testing agency which tests in accordance with UL standards.

Check with your insurance company and local building inspector to make sure you can use a woodstove without large penalties in the form of higher premiums or extensive remodeling.

Compare the expected heat output of various types of wood with alternative fuels. You will then be in a position to compare costs on an available energy basis.

Make sure you have access to or can install a suitable chimney for your stove.

Look at several different stove types and visit with people who are using them. Are they satisfied with the performance? Have they had any problems with the unit? Has the dealer been willing to correct any problems?

Examine stoves for quality workmanship. Are materials sturdy and parts well put together? Modern stoves gain efficiency from their ability to control combustion air. This requires an airtight unit with close fitting parts and a tight or gasketed door.

## **STOVE TYPES**

Many types of Woodburning stoves are available. Most fall into one of the following general categories, although further definition is provided by the National Fire Protection Association.

### **CIRCULATING ROOM HEATERS:**

These are double-walled with an inner combustion chamber usually constructed of cast iron or firebrick-lined welded steel. An outer shell of lightweight sheet metal promotes the flow of air over the inner shell. The room is heated primarily by warm air. You obtain draft control and heat output with a thermostatically operated damper. Burning efficiencies of 60 to 70 percent are possible with well-built units.

The major advantage of the circulating unit is the relatively cool outer shell during operation.

### **RADIANT ROOM HEATERS:**

These single walled units may be constructed of sheet metal, cast iron, or welded steel. They may or may not be lined with firebrick, which improves a stove's efficiency and prolongs its life.

Heat is transferred to the room directly by radiant energy and indirectly by convection currents set up by air flow over the surface of the stove unit. The early American “pot bellied stove” falls into this general category, as do many of today’s imported and domestic units. Draft and heat control may be automatic but are more often obtained by manually operated dampers.

Combustion efficiency for these units can be as high as for the circulating units. Lower efficiencies are associated with poor management of manual draft controls.

## **ROOM HEATER/FIREPLACE STOVE COMBINATION:**

These units combine the look and feel of an openfired “Franklin Type” stove with the efficiency of a closed unit. These radiant type heaters have a door which can be opened to provide a view of the fire without adversely affecting stove operation. When the door is closed, these units operate the same as other stoves. Overall efficiencies are in the 50 to 60 percent range, depending on the amount of time units are operated in the “fireplace” modes. This compares to efficiencies of 10 to 20 percent for the usual home fireplace.

## **CONSTRUCTION**

The UL listed stove you buy will have a sheet metal, welded steel, or cast iron fire box. It may also be lined with firebrick.

Sheet metal stoves are the lowest in cost and should be considered only for occasional use. Since they are light in weight, they warm up rapidly. However, extensive use leads to early burnout. Their life can be prolonged by limiting the size of fires or by lining the fire area with heavier material or firebrick. Sheet metal stoves should be examined frequently for weak, burned out spots.

Welded steel stoves are constructed of 1/4 inch thick or thicker steel plate. They warm up more slowly than sheet metal stoves, but the thicker wall section lasts longer. These units are suitable for continuous use. High quality models will have firebrick lining in the combustion area.

Cast iron has long been considered “top of the line” in Wood-burning stoves. It provides a stove which warms up slowly, retains

heat well, does not warp, and lasts for many years. However, a cast-iron stove is no more efficient than well constructed stoves of other types. Cast iron is relatively brittle and is subject to cracking if roughly handled. For this reason, new and used cast-iron units should be carefully inspected for breaks before using them.

Firebrick or ceramic liners may be used in any of the three stove types. Liners add mass to the stove and tend to spread heat away from hot spots in the fire. This promotes more uniform heating and prolongs the useful life of the stove. Liners also lengthen the time between starting of the fire and the heating of the room.

## **LOCATING THE STOVE**

Stove placement is usually determined by location of an existing chimney flue or by the potential location for a chimney. The stove should be located as close as possible to the chimney inlet, while maintaining required clearances to combustibles.

Some woodstoves are not designed with positive circulation systems. Locate these stoves near the center of the area to be heated.

## **INSTALLATION**

Manufacturer's installation instructions must be strictly adhered to. Adequate clearance must be maintained between the stove and any combustible surface. A stove placed too close to a wall or furniture can cause a fire. Remember, chimneys and connector pipes do get dirty. Make sure your woodstove is installed in a manner that will permit access to both the connector pipe and the chimney flue for the periodic cleaning necessary to remove soot and creosote buildup on the interior surfaces.

## **CLEARANCES (See figure 1)**

Most home fires involving woodstoves are the result of improper installation or operation. To reduce the possibility of fire, the National Fire Protection Association (NFPA) has recommended clearances between woodstoves and protected and unprotected combustible walls and ceilings. Table 1 illustrates these clearances and shows clearance reduction when various protection is installed.

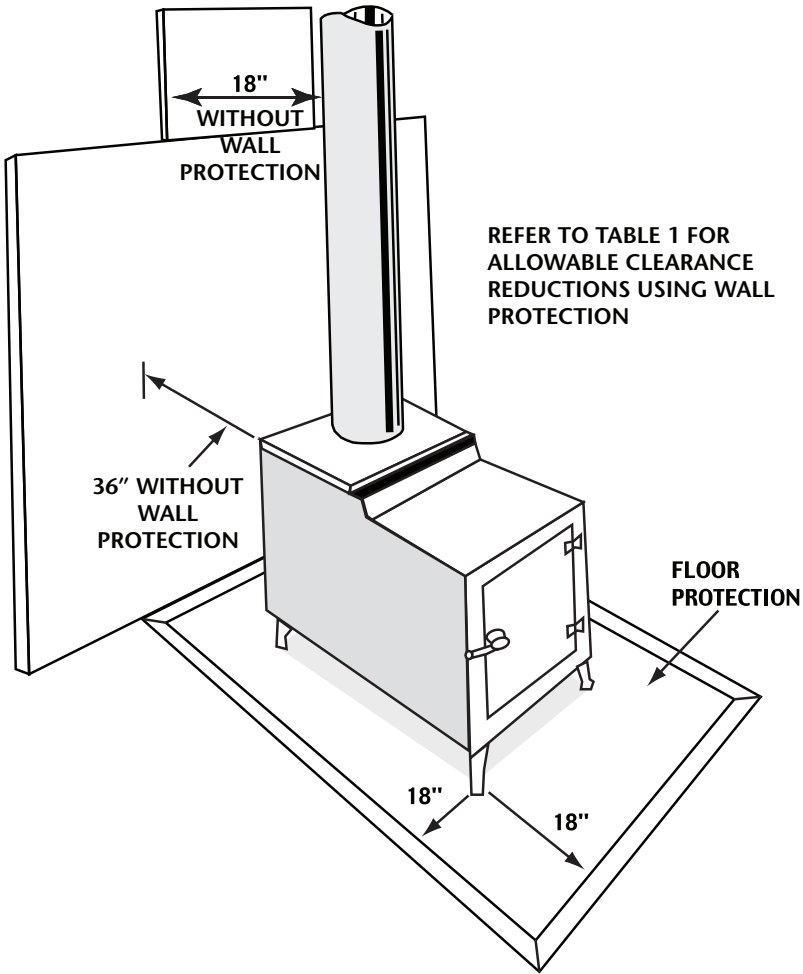

**Figure 1**

# Table 1

## Reducing Clearance from the Woodburning Appliance and Connector Pipe

It is possible to reduce manufacturer's or NFPA 211 recommended clearances from the woodburning appliance and connector to combustible surfaces. When the required clearance with no protection is 36 inches or 18 inches respectively, the allowable clearance reduction is shown below.

Combustible Surface Covering	As Wall Protector		As Ceiling Protector	
	appliance	connector	appliance	connector
1. 3 1/2 in. thick masonry wall without ventilated air space.	33%-24"	33%-12"		
2. 1/2 in. thick non-combustible insulation board over 1 in. glass fiber or mineral wool batts without ventilated air space.	50%-18"	50%-9"	33%-24"	33%-12"
3. 24 gage sheet metal over 1 in. glass fiber or mineral wool batts reinforced with wire or equivalent, on rear face with 1 in. ventilated air space.	66%-12"	66%-6"	50%-18"	50%-9"
4. 3 1/2 in. thick masonry wall with 1 in. ventilated air space.	66%-12"	66%-6"		
5. 24 gage sheet metal with 1 in. ventilated air space.	66%-12"	66%-6"	50%-18"	50%-9"



**Table 1 (continued)**

Combustible Surface Covering	As Wall Protector		As Ceiling Protector	
	appliance	connector	appliance	connector
6. 1/2 in. thick non-combustible insulation board with 1 in. ventilated air space.	66%-12"	66%-6"	50%-18"	50%-9"
7. 1 in. glass fiber or mineral wool batts sandwiched between two sheets of 24 gage sheet metal with 1 in. ventilated air space.	66%-12"	66%-6"	50%-18"	50%-9"

**NOTE: After reduction, appliance clearance shall be not less than 12 inches to combustible walls and not less than 18 inches to combustible ceilings.**

**Connector clearance shall be not less than 6 inches to combustible walls and not less than 9 inches to combustible ceilings.**

**Non-combustible spacers must be used. Refer to NFPA 211 for further details.**

All floors under stoves (except solid concrete) must be protected from heat and coals which may fall out. This protection should extend under the stove and outward for a distance of 18 inches on all sides. Manufacturers of listed heaters usually specify the type of material required for floor protection. If manufacturer's specifications are not known, the type of floor protection required for heaters depends on heater leg length. Heaters with legs less than 2 inches in height can only rest on a non-combustible floor. Heaters with legs 2 inches to 6 inches must have floor protection consisting of 4 inch hollow masonry laid to provide air circulation through the layer and covered with 24-gage sheet metal. Heaters

with legs higher than 6 inches must have floor protection consisting of closely spaced masonry which provides a thickness of not less than 2 inches. Such masonry must be covered by 24-gage sheet metal. Instead of the requirements for floor protection specified here, a floor protector listed by a recognized testing laboratory and installed in accordance with the listing may be employed.

Legs installed by the manufacturer should not be shortened or removed; nor should any item be placed where it will interfere with circulation of air under the stove.

## **CONNECTING PIPE**

Stoves are connected to chimney inlets with uncovered sheet metal pipe known generally as stove pipe or smokepipe. This pipe is usually six or eight inches in diameter and should be constructed of 24 gage or heavier metal. (The lower the gage number, the heavier the metal.) Pipe size should match the outlet size of the stove.

Maximum efficiency is obtained when pipes are as short and as straight as possible.

If the pipe runs horizontally to the chimney, a minimum slope should be 1/4 inch per foot toward the stove. Joints in the pipe should be assembled to funnel any liquid creosote accumulating in the pipe back to the stove where it will burn. Joints should fit tightly to eliminate entry of room air directly into the chimney system. Furnace cement may be used to insure tightness. Rivets or screws can be used at pipe joints for added strength. A minimum of three rivets or screws is recommended at each joint. To reduce fire potential, maintain the recommended clearance of 18 inches between the pipe and combustibles.

## **CONNECTING PIPE TO CHIMNEY INSTALLATION**

If the pipe must pass through a combustible wall, at least 12 inches of solid masonry around a 5/8" fire clay tile thimble must be constructed in the wall. (See Figure 2.) The use of a UL listed prefabricated wall pass through is also acceptable. In no case should a pipe extend through an area of the house which is unoccupied.

When using a factory built chimney, the wall pass through (See Figure 3) or ceiling support (See Figure 4) is manufactured and listed as part of the venting system. Installation must conform to the manufacturer's specifications.

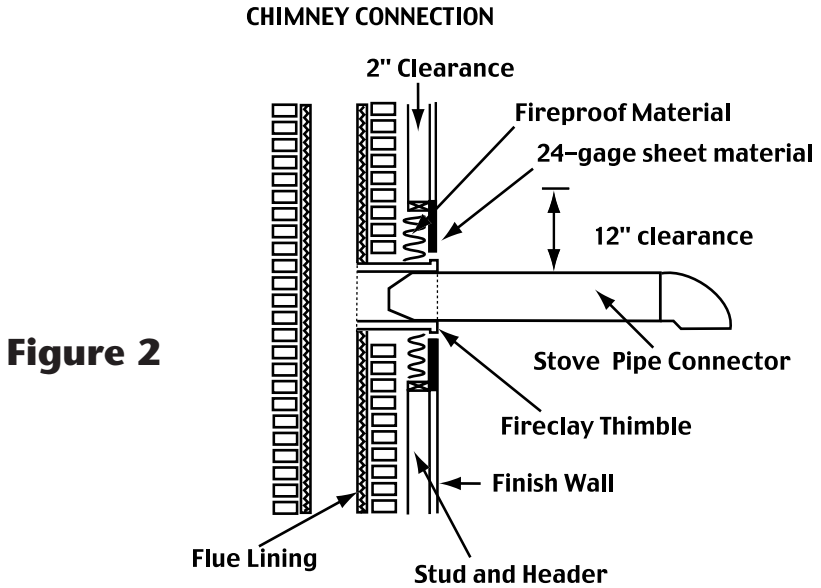

**Prefabricated Chimney – Outside Installation**

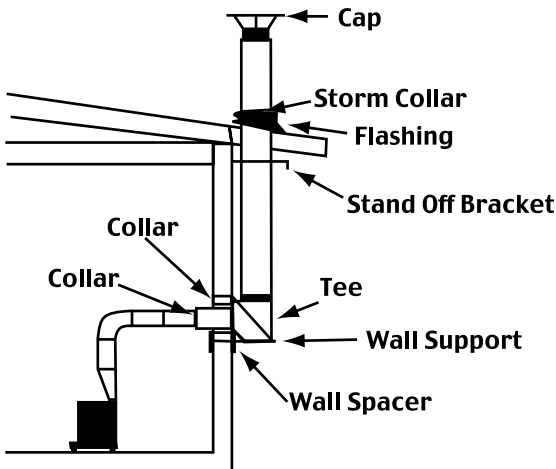

**Figure 3**

## Prefabricated Chimney — Interior (Preferred) Installation

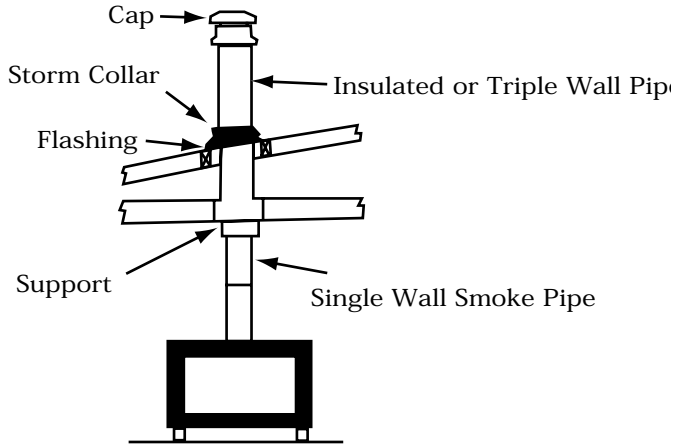
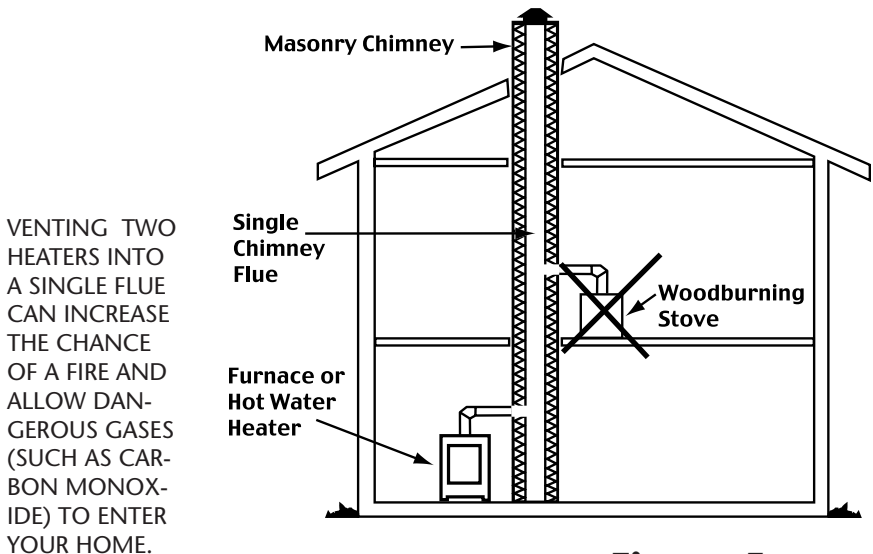

**Figure 4**

## MULTIPLE VENTING

Unless listed for such connection, solid fuel burning appliances should not be connected to a chimney flue serving another appliance such as gas or oil fired furnaces and water heaters.



(See Figure 5)



**Figure 5**

## OPERATION

Once a good stove has been selected and installed correctly, the next important factor is proper operation. Many problems which arise with a correctly installed stove are the direct result of incomplete combustion.

Stages of Combustion	
<p><b>1st Stage</b></p> 	<p>The wood is heated to evaporate and drive off moisture.</p> <p>This heat <u>does not</u> warm the stove or room.</p>
<p><b>2nd Stage</b></p> <p>500° F to 1100° F</p> 	<p>The wood starts to break down chemically at 500° F and <u>volatile matter is vaporized.</u></p> <p>These vapors contain between 50–60% of the heat value of the wood.</p> <p>At 1100° F these vapors burn. This high temperature must be maintained for <u>maximum efficiency of combustion.</u></p>
<p><b>3rd Stage</b></p> <p>Over 1100° F</p> 	<p>Following the release of volatile gases, the remaining material is <u>charcoal</u>, which burns at temperatures exceeding 1100° F.</p>

**Figure 6**

## COMBUSTION (See Figure 6)

Combustion consists of a complex chemical reaction between the fuel (wood) and oxygen. The combustion of wood in a stove results in heat and water vapors, carbon dioxide, and other products of combustion (gases and ash). To assure satisfactory combustion and safe operation, several conditions must be met:

*A continuous supply of oxygen for the fire and the occupants of the room or area.*

*A proper amount of fuel (wood) - not enough to cause overheating, but enough to maintain a flue temperature that prevents the accumulation of creosote residues.*

*Proper burning - to avoid wasted fuel and toxic products of combustion, such as carbon dioxide.*

*Removal of unwanted products of combustion -gaseous products should be continuously removed while the stove is in operation, and solid products (ashes) should be disposed of safely.*

Complete combustion can be assured by supplying air and maintaining a sufficient heat level. Incomplete combustion results from an insufficient air supply, misapplied air, or insufficient heat.

New stoves with cast-iron parts should be “seasoned” to avoid cracking. Do this by building only small fires for the first two or three times.

The entire system must be properly maintained to operate safely and efficiently. The chimney connectors, joints, and flues must be clean and in proper working order.

## **CONTROL CREOSOTE**

When wood is burning rather slowly, the smoke usually contains a substance called creosote that collects in the relatively cool chimney flue. The main causes of creosote buildup are:

*Wet or unseasoned wood.*

*Incomplete combustion.*

*Cool surfaces.*

The best method of controlling creosote buildup is by maintaining a briskly burning fire with dry, well seasoned wood and by maintaining a flue temperature exceeding 250 degrees F.

Some new, more efficient stoves deliver more heat to the room than an open stove or fireplace, thus reducing the amount

of heat escaping up the chimney and lowering the flue temperature. Make sure that creosote is not building up in these stoves. Additional inspections and clean-outs may be needed.

## **CHIMNEY FIRES**

With the increased accumulation of creosote in the flue comes the increased possibility of a chimney fire. The combustion of these creosote deposits is more likely to occur during a very hot fire in your stove. The burning of creosote deposits results in a very intense fire, a roaring noise, and flames and sparks from the top of the chimney.

Any chimney, metal or masonry, can be weakened or deformed by a chimney fire. The complete chimney should be inspected after a fire, and any repair should be made or parts replaced before re-starting the stove.

### **IF A FIRE OCCURS ...**

If a fire occurs, follow these steps to reduce your loss:

**CALL YOUR LOCAL FIRE DEPARTMENT IMMEDIATELY**

**CLOSE ALL OPENINGS AND DRAFT CONTROLS ON THE STOVE**

If the fire is burning vigorously, squirt a multipurpose dry chemical extinguisher onto the fire in the stove. If possible, avoid introducing water into the chimney: the water could damage relatively brittle heated flue liner.

## **CHIMNEY INSPECTIONS AND CLEANING**

Stove pipes and chimney flues should be inspected each year before you use your stove. Look for cracked flue liners, broken or missing chimney bricks, heavy creosote deposits, bird nests, and other foreign material. Thoroughly clean the flue and connecting pipe when necessary.

The stove pipe and chimney should be inspected frequently during the heating season for creosote buildup. If you use an air tight stove, check the connecting pipe and flue at least once a month.

How often a flue needs cleaning depends on how frequently a stove is used and how it is operated. If there is excessive buildup, a stiff wire chimney cleaning brush should be used. Utilizing a professional chimney sweep for cleaning is recommended.

If using an existing chimney, always have your chimney cleaned before your woodstove is installed. Many people have begun to utilize the services of professional chimney sweeps.

## **DISPOSAL OF ASHES**

Store ashes in a non-combustible metal container with a tight fitting lid. The closed container should be placed on a non-combustible floor or on the ground, well away from all combustible materials, pending final disposal. Keep ashes away from small children. Swallowing ashes could cause illness.

## **FIRE EXTINGUISHERS AND SMOKE DETECTORS**

In addition to the extinguishers already in the home, a multi-purpose ABC dry chemical fire extinguisher should be installed for each stove. The extinguisher should be located near the stove and easy to reach. To offer your family additional protection in case of fire, equip your home with smoke detectors. These may be required by law.

## **SPECIAL SAFETY POINTS**

Because of high temperatures when the stove is operating, locate the heater out of traffic and away from furniture and draperies.

Alert children to the hazard of high surface temperatures and keep them away from the stove to avoid burns or clothing ignition.

Carefully supervise young children when they are in the same room with the heater.



A qualified person should install and service the stove and inspect it before use and at least annually.

Keep combustible materials away from heaters to avoid the possibility of ignition. Some common combustible materials include walls, ceiling, furniture, rugs, draperies, fuel and clothing.

## **CHIMNEYS FOR WOODSTOVES**

All woodburning stoves need a tight, well designed and constructed chimney to maximize efficiency and to minimize the danger of unwanted fire. Most homeowners who add a wood-burning stove will also have to add a chimney. This guide explains some basic chimney requirements and provides basic information on the construction of the two general types, masonry and factory-built.

The chimney serves two major functions in stove operation. It provides a draft, a vacuum which draws oxygen needed for combustion into the stove. It also discharges the products of combustion outside the living area. Some of the heat from the stove and occasional sparks are also discharged through the chimney. For this reason, chimneys must be carefully constructed and well maintained.

Draft is caused primarily by the natural rising of warm air (smoke) up the chimney. In general, the taller the chimney, the greater the draft. (A warm chimney will provide greater draft than a cool chimney because a warm chimney does not cool the rising smoke.) This is why stoves generally perform better after they have run long enough to warm the chimney. For the same reason, chimneys which are located within the house generally produce better draft than those located completely outside the house.

Outside air currents can affect draft if they swirl around obstructions and blow down the chimney rather than across the outlet. Eddy currents of air that affect draft are most often caused by wind blowing across nearby parts of the building roof. For this reason, certain clearances have been established to lessen the problem. A chimney must extend at least three feet above a roof and at least two feet above a roof ridge or any raised part of a roof within 10 feet. See Figure 7 for an illustration of these clearances.

Sometimes getting enough vertical clearance to prevent eddy currents from affecting chimney draft is impossible. This may be because of unusual heights of nearby trees. A hood or chimney

To prevent downdrafts and fire from sparks, chimney height must be at least 2 feet above any roof surface within 10 feet horizontally.

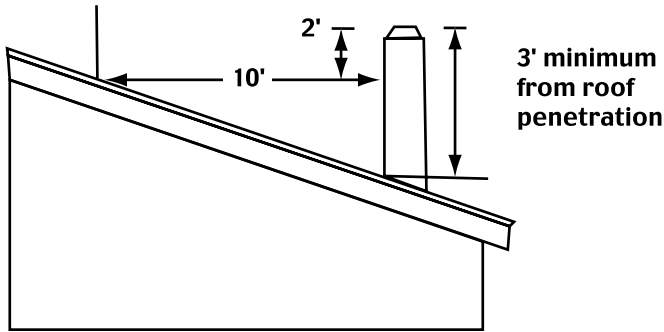

**Figure 7**

cap can sometimes be used to prevent eddies from interfering with draft. Caps and hoods also minimize rain entry into the chimney during periods of non-use.

## **FLUE**

The opening in the chimney through which smoke passes is called the flue. To provide adequate room for smoke passage and draft development, flues must be carefully sized in relation to stove capacity and chimney height. In general, flue size should be equal to and no more than 3 times larger than the cross sectional area of the stove pipe which connects the stove to the chimney. This means a stove with a six-inch diameter pipe would require at least a six-inch, but no more than approximately a ten-inch flue.

Smoke moves up the flue in a swirling pattern. Round flues are more efficient than square or rectangular ones because they offer little obstruction to the natural flow of smoke. For best performance, the inner surface of flues should be as smooth as possible.

One frequently asked question about chimneys for woodstoves is "Can a stove be connected to an existing flue that serves another appliance?" National Fire Protection Association (NFPA)

recommended standards prohibit connecting a stove to a chimney flue serving another appliance burning dissimilar fuels unless listed for such connection. This requirement has been incorporated into most building codes and insurance regulations. The NFPA recommends that each stove be connected to a separate flue. This reduces interference between units and increases the efficiency of each stove.

## **MASONRY CHIMNEYS**

Many chimneys in new and existing homes are constructed of noncombustible masonry material. This may be brick, chimney block, or stone. Masonry chimneys must be constructed on a concrete footing to support the chimney without settling. Chimney footings must extend below normal frost depth and rest on undisturbed or well compacted soil.

Masonry chimneys should be lined with vitrified fire clay tile (flue tile), or other listed lining material (See NFPA 211). This tile is designed to withstand rapid fluctuations in temperature without cracking and has a smooth surface that is easily cleaned.

Flue tile should be at least 5/8 inch thick. It is available in several sizes. The most commonly used sizes in residential construction are 8 by 8 inches, 8 by 13, and 13 by 13 (outside dimensions). Flue tiles are cemented together with refractory mortar, which is struck smooth on the inside. There should be a minimum 1/2 inch and maximum 4 inch space between the outside of the flue tile and the surrounding masonry to reduce heat loss through the chimney and allow for thermal expansion. Relining of masonry chimneys is acceptable as long as listed products are installed according to their listing.

Brick walls for chimneys must be at least four inches thick. If rubble stone is used for the wall, a 12 inch minimum thickness is needed. Chimney block may also be used. The block must be 4 inch solid masonry or 6 inch hollow masonry with the cells fully filled with mortar. In both cases, the block must be waterproofed. Masonry units should be laid with cement mortar.

A chimney may contain more than one flue; however, they should be separated by nominal 4-inch thick solid masonry.

Interior masonry chimneys must be separated from combustible material by at least two inches on all sides. This means that framing and other combustible material in walls, floors, ceil-

ings, and roofs must stop at least two inches from the chimney. This two-inch space must be filled with sheet metal or other non-combustible material to provide a fire stop.

Connection of the smokepipe to a masonry chimney is made through the use of 5/8" thick round fire clay or 24 gage galvanized steel units called thimbles. These are installed horizontally into the chimney wall. Thimbles must not extend into the chimney beyond the inner surface of the flue liner. (See figure 2.)

Soot and creosote will accumulate on the inner surface of flues. A tight fitting clean-out door should be installed at the base of the chimney to assist in cleaning.

## **FACTORY-BUILT CHIMNEY UNITS**

Masonry chimney units cannot be easily added to many existing homes and are not practical in some new home designs. A listed factory-built chimney unit may be the best choice for woodstoves or fireplaces in these homes.

Factory-built chimneys are easier to erect than masonry units, and although materials cost more, total unit cost will be nearly the same. These units are relatively light weight and need no heavy foundation. These can often be installed through a closet or unused room corner in an existing home. In this situation, the chimney must be enclosed and minimum clearance requirement maintained.

Factory-built chimneys used for woodstoves must bear the Underwriters Laboratories (UL), (Note: Underwriters Laboratories of Canada listings may apply), listed label and be designed as "all fuel" chimney units. UL listed vents commonly used for oil or gas fired heaters are not satisfactory for use with woodstoves.

There are two UL listings which must be noted. UL 103 and UL 103 HT. The 103 HT chimney is required with stoves that operate with the loading door closed.

Freestanding fireplaces and heaters that operate with the door open can be connected to chimneys with the UL 103 listing. The UL 103 HT listing requires more severe testing criteria.

There are two general types of factory-built chimneys available. They are the insulated unit and the triple walled unit. The insulated unit is constructed of inner and outer layers of metal (usually stainless steel) with the space between filled with one or more inches of non-combustible insulation. Triple walled units

have three layers of metal and are designed so that air circulates between the layers and removes excess heat. Either type is satisfactory as long as it is UL listed, properly installed, and is suited for the heater it is being used with.

Factory-built chimneys are available in several sizes, and a variety of accessories are available to accommodate different types of installation. There generally is a required two-inch clearance between these units and combustible material. Manufacturers' installation requirements must be adhered to.

## **SMOKY FIRES**

Sometimes even properly constructed and operated stove-chimney combinations result in smoky fires. Each of the following items can cause smoky fires.

## **CHIMNEY OBSTRUCTIONS:**

Bird nests, fallen bricks, and a variety of other objects have all been found in chimneys. Any object which restricts the smooth flow of exhaust gases can cause smoky fires. A good cleaning is the solution to this problem.

## **LACK OF COMBUSTION AIR:**

Occasionally in a new, tightly constructed home there will not be enough natural openings to supply air for the stove. This restricts the chimney draft and results in smoking. Opening a window slightly or providing some other source of outside air will usually eliminate this problem.

Occasional smoking can be caused by:

- (a) Unusual wind direction resulting in abnormal eddy currents. If this is a persistent problem, extending chimney height or adding a cap may help.
- (b) Burning green or wet wood or too cool of a fire. These can prevent the chimney from warming up and developing full draft. If wet or green wood must be burned, wait until the fire is going well and then mix it with dry wood to keep chimney temperature up.

## **WOOD**

Burn dry and well-seasoned hardwood. Season wood at least six months, preferably a year to eighteen months. Woodburners who ignore this advice are likely to have dirty chimneys and inadequate heat from their stoves.

If you buy green wood, season it before using. With some experience, you can spot green wood easily. It is heavier and looks different. Seasoned wood will often show cracks radiating outward from the heartwood toward the bark, like wheel spokes. Green wood will not show this pattern of cracks.

## **FIRING INSTRUCTIONS FOR WOOD STOVES**

Cover the bottom of the stove with an inch or so of sand. This protects the floor and the bottom plate from extremes of heat.

To start the fire, place a small pile of paper and kindling at the front of the stove. Place heavier wood on the kindling. A wad of paper placed in front of the kindling works well. The draft will draw flame from the paper through the kindling, igniting it.

Do not do anything that will cause sudden sharp changes in the temperature of the cast iron. Do not throw cold water on a hot stove. Do not use the stove as an incinerator for trash.

Do not store wood near or under the stove.

**NEVER use gasoline, kerosene; charcoal starter, or similar liquid to start a fire.**



**NAMIC<sup>®</sup>**

National Association of  
Mutual Insurance Companies

3601 Vincennes Road

P. O. Box 68700

Indianapolis, IN 46268

(317) 875-5250

[www.namic.org](http://www.namic.org)