



Introduction to Article 250 – Grounding and Bonding

The purpose of the *National Electrical Code* is the practical safeguarding of persons and property from hazards arising from the use of electricity [90.1(A)]. In addition, the *NEC* contains provisions that are considered necessary for safety. Compliance with the *NEC* combined with proper maintenance shall result in an installation that is essentially free from hazard [90.1(B)].

Understanding the Basics of Electrical Systems

Contrasting the electric utility system wiring, which is governed by the National Electrical Safety Code (NESC), with those of premises wiring which are covered by the *NEC*, should be helpful to enhance an understanding of some basic electrical principles such as current flow, neutral and fault-current paths.

Utility Current Flow. Electrons leaving a power supply are always trying to return to the same power supply; they are not trying to go into the earth. When alternating current is applied to the primary of a transformer, it induces a voltage in the secondary. This induced secondary voltage causes electrons to leave one end of the transformer’s secondary, travel over the circuit’s conductors through the load and return over the remaining circuit’s conductors to the other end of the transformer’s secondary. Figure 250-1

Utility Neutral Current Path. The electric utility grounds the primary and secondary neutral conductor to the earth at multiple locations to create a parallel path so as to reduce the impedance of the return neutral current path. This multipoint grounded

utility neutral helps in reducing primary utility neutral voltage drop, the clearing of utility line-to-neutral faults and in reducing elevated line-to-ground voltages caused by ground faults. Figure 250-2

Utility Ground-Fault Current Path. Metal parts of the electric utility equipment (transformer and capacitor cases, guy wires, luminaires, etc.) are grounded to the earth and bonded to the grounded (neutral) conductor to provide a low-impedance parallel path for the purpose of clearing a line-to-case ground fault. If the utility grounded (neutral) conductor is inadvertently opened, the earth itself should still have sufficiently low impedance to permit sufficient fault current to flow to blow the fuse, thereby clearing the high-voltage ground fault.

For example, a 7,200V line is typically protected by a 60A to 100A fuse (depending on wire size). The earth, having an impedance of 25Ω, would have no problem carrying sufficient fault current to blow a 100A fuse. ($I = E/Z$, $I = 7,200V/25\Omega$, $I = 288A$). Figure 250-3

Premises Neutral Current Path. Neutral current should only flow on the grounded (neutral) conductor, not on metal parts of the electrical installation [250.6]. Figure 250-4

Premises Ground-Fault Current Path. Metal parts of premises wiring are bonded to a low-impedance path designed and intended to carry fault current from the point of a line-to-case fault on a wiring system to the grounded (neutral) conductor at the electrical supply source. This low-impedance fault-current path

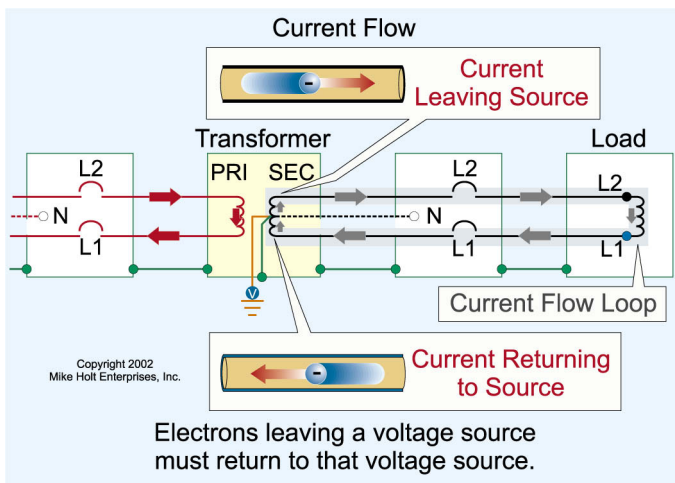

Figure 250-1

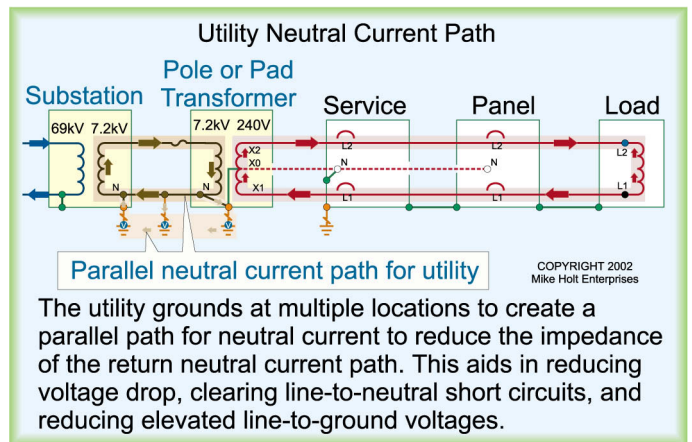

Figure 250-2

250.10 Protection of Grounding Fittings

Ground clamps and other grounding fittings shall be protected from physical damage by:

- (1) Locating the grounding fitting where they are not likely to be damaged
- (2) Enclosing the grounding fittings in metal, wood, or equivalent protective covering

AUTHOR'S COMMENT: Grounding fittings are permitted to be buried or encased in concrete if installed in accordance with 250.53(G), 250.68(A) Ex. and 250.70.

250.12 Clean Surface

Nonconductive coatings such as paint, lacquer and enamel shall be removed on equipment to be grounded or bonded to ensure good electrical continuity, or the termination fittings shall be designed so as to make such removal unnecessary [250.53(A) and 250.96(A)].

AUTHOR'S COMMENT: Some feel that "tarnish" on copper water pipe should be removed before making a grounding termination. This is a judgment call by the AHJ.

Part II. System and Equipment Grounding

250.20 Alternating-Current Systems to be Grounded

System (power supply) grounding is the intentional connection of one terminal of a power supply to the earth for the purpose of stabilizing the phase-to-earth voltage during normal operation [250.4(A)(1)].

- (A) AC Circuits of Less than 50V.** Alternating-current circuits supplied from a transformer that operate at less than 50V are not required to be grounded unless:
- (1) The primary is supplied from a 277V or 480V circuit.
 - (2) The primary is supplied from an ungrounded power supply.

AUTHOR'S COMMENT: Typically, circuits operating at less than 50V are not grounded because they are not supplied from a 277V or 480V system, nor are they supplied from an ungrounded system. Figure 250-48

- (B) AC Systems Over 50V.** Alternating-current systems over 50V that require a grounded (neutral) conductor shall have the grounded neutral terminal of the power supply grounded

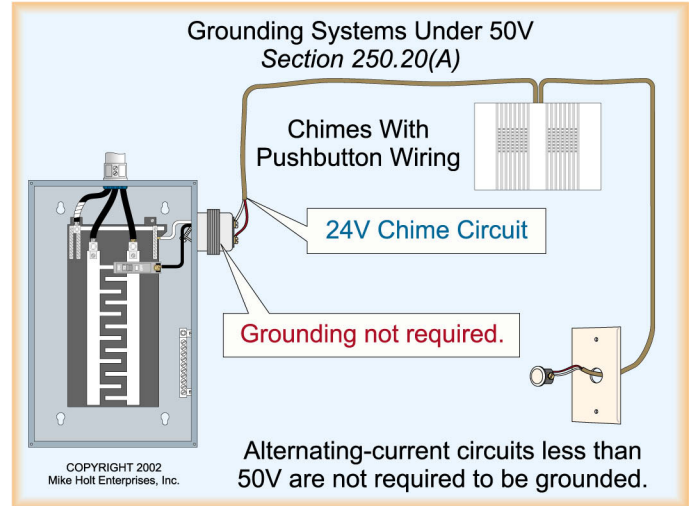

Figure 250-48

to earth in accordance with 250.4(A)(1) and 250.30(A)(1). Such systems include: Figure 250-49

- 120V or 120/240V single-phase systems
- 208Y/120V or 480Y/277V, 4-wire, 3-phase, wye-connected systems
- 120/240V 4-wire, 3-phase, delta-connected systems

AUTHOR'S COMMENT: Other power supply systems, such as a corner-grounded delta-connected system, are permitted to be grounded [250.26(4)], but this is beyond the scope of this book.

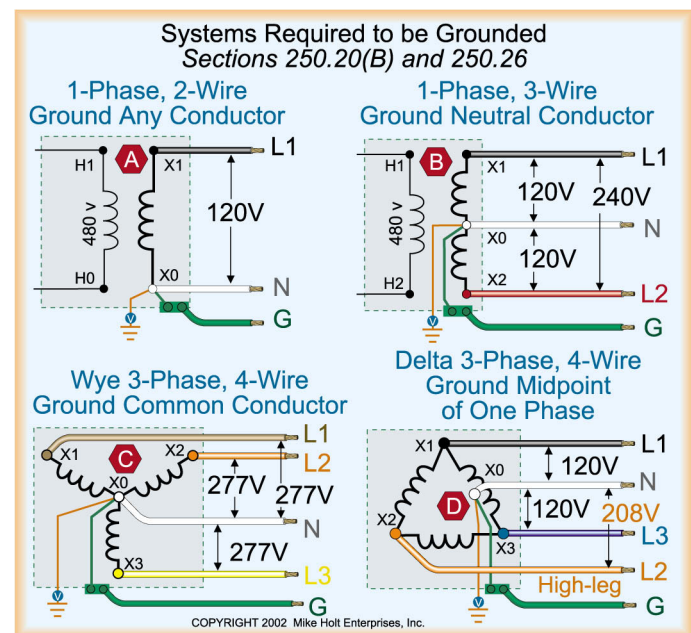

Figure 250-49

Article 250

1. A ground fault is a(n) _____ electrical connection between an ungrounded (hot) conductor and metallic enclosures, metallic raceways, metallic equipment, or earth.
(a) deliberate (b) intentional (c) designed (d) unintentional
2. An effective ground-fault current path is an intentionally constructed low-impedance path designed and intended to carry fault current from the point of a line-to-case fault on a wiring system to _____.
(a) ground (b) earth
(c) the electrical supply (neutral) (d) none of these
3. An effective ground-fault current path is created when all electrically conductive materials that are likely to be energized are bonded together and to the _____.
(a) ground (b) earth
(c) electrical supply (neutral) (d) none of these
4. Electrical systems that are grounded shall be connected to earth in a manner that will _____.
(a) limit voltages due to lightning, line surges, or unintentional contact with higher-voltage lines
(b) stabilize the voltage-to-ground during normal operation
(c) facilitate overcurrent protection device operation in case of ground faults
(d) a and b
5. Non-current-carrying conductive materials enclosing electrical conductors or equipment, or forming part of such equipment, shall be connected together to the _____ in a manner that establishes an effective ground-fault current path.
(a) ground (b) earth
(c) electrical supply (neutral) (d) none of these
6. Electrical equipment and wiring, and other electrically conductive material likely to become energized, shall be installed in a manner that creates _____ likely to be imposed on it from any point on the wiring system where a ground fault may occur to the electrical supply source.
(a) a permanent path
(b) a low-impedance path
(c) the capability of safely carrying the ground-fault current
(d) all of these
7. The earth can be used as the sole equipment grounding conductor.
(a) True (b) False
8. Grounding electrode conductor fittings shall be protected from physical damage by being enclosed in _____.
(a) metal (b) wood
(c) the equivalent of a or b (d) none of these