

## Table of Contents

### Light Gauge Metal Roof & Wall Panels

<b>Section</b>	<b>Section</b>		
Introduction . . . . .	2	Slope Transition - High to Low Slope . . . . .	29
Minimum Recommended Tools & Equipment. . . . .	3	Slope Transition - Low to High Slope . . . . .	30
Delivery, Handling & Storage . . . . .	4	Chalet Gable Flashing . . . . .	31
Safety Considerations. . . . .	4	Adjustable Gable Flashing. . . . .	32
Roof Preparation . . . . .	5-6	Vent Flashing . . . . .	33
Map of Typical Roof Conditions . . . . .	7	Vent/Pipe Flashing Installation Procedure. . . . .	34
Trim Locations . . . . .	8	Skylight Flashing . . . . .	35
Fastener Placement . . . . .	9	Skylight Flashing (Side) . . . . .	35
Fastener Selection . . . . .	10	Skylight Flashing (Uphill Side). . . . .	36
Panel Installation . . . . .	11	Skylight Flashing (Downhill Side) . . . . .	37
Hip/Ridge Flashing. . . . .	12	Procedure for the Installation of	
Universal Ridge Termination. . . . .	13	Skylight Flashings . . . . .	38
Vented Ridge Flashing . . . . .	14	Skylight Flashing Preparation. . . . .	38-39
Vented Ridge Termination. . . . .	15	Chimney Flashing . . . . .	40
Valley Flashing. . . . .	16	Chimney Flashing (Side) . . . . .	41
Valley Termination . . . . .	17	Chimney Flashing (Uphill Side). . . . .	42
Eave and Vented Eave Flashings. . . . .	18	Chimney Flashing (Downhill Side) . . . . .	43
Eave Flashing Preparation . . . . .	19	Valley Top End. . . . .	44
Gutter and Vented Gutter Flashing . . . . .	20	Valley Dormer . . . . .	45
Gable Flashing. . . . .	21	Panel End Lap . . . . .	46
Gable/Ridge Transition . . . . .	22	Sealing End Laps & Lapping the Hems . . . . .	47
Gable Corner at Eave. . . . .	22	Window/Door Trim Corner Wall Detail. . . . .	48
Gable Flashing Preparation . . . . .	23	Base Trim, Wall Step, Panel Top Wall Detail. . . . .	49
Gable Flashing Preparation at Ridge. . . . .	24	Inside Corner Wall Detail . . . . .	50
Peak Flashing . . . . .	25	Outside Corner Wall Detail. . . . .	51
Sidewall Flashing. . . . .	26		
Endwall Flashing . . . . .	27		
Vented Endwall Flashing . . . . .	28		

# Light Gauge Metal Roof and Wall Panels

Installation Guide for Delta Rib, Delta Rib III, Nor-Clad®, Strata Rib® & 2½ Corrugated



## Introduction

In addition to weather tightness, long life, good looks and economy, ASC Building Products' Light Gauge Roof and Wall Panels are designed with ease of installation as a primary consideration. This guide is intended to help the installer achieve a high level of quality in the finished product. Please do not hesitate to contact an ASC Building Products representative for assistance.

## Manufacturing Locations:

### **Anchorage, Alaska**

2441 Cinnabar Loop  
Anchorage, AK 99507

### **McClellan, California**

5001 Bailey Loop  
McClellan, California 95652

### **Salem, Oregon**

4063 Salem Industrial Drive NE  
Salem, OR 97303  
800-272-7023 • 503-390-7174

### **Salt Lake City, Utah**

4228 West 1730 South  
Salt Lake City, UT 84104

### **Spokane, Washington**

4111 East Ferry  
Spokane, Washington 99202  
800-776-8771 • 509-536-4097

## Important Notice

### **Be sure to read this manual in its entirety before beginning installation.**

This manual is provided to the customers of ASC Building Products as a guide to assist in the installation of Light Gauge Metal Roof and Wall Panels. Use for any other purpose is prohibited. This manual remains the property of ASC Building Products.

These instructions contain suggested application procedures only and cannot replace the need for good common sense and experience. Responsibility for conformance to state and local building codes, as well as any other applicable project requirements rests with the installer, as does the responsibility to observe reasonable safety procedures.

ASC Building Products assumes no responsibility for any problems which might arise as a result of improper installation or any personal injury or property damage that may occur with the product's use.

*Notes:* It is recommended that Light Gauge Roofing be applied on roofs with a minimum slope of 3 inches per foot (3:12).

\* The details contained in this guide are shown over a plywood substrate. Details remain the same for either a solid substrate (plywood or steel), spaced framing or intermittent support condition with only the fastener type changing. Where spaced framing is used, perimeter supports for flashings must be considered.

\*\*Each flashing part in this guide has been assigned a part number. Each part number contains one or two letters followed by one or two numbers, for example: (EW17). These part numbers have been provided for you to make ordering these flashing parts quick and easy.

## Minimum Recommended Tools & Equipment

**Screw Gun:** Clutch type screw gun with depth locating nose piece allowing variable torque settings is recommended to insure proper installation of the screws. The following sockets will be required: 1/4" and/or 5/16" hex.

**Snips:** For miscellaneous panel and flashing cutting requirements. Three pairs will be required for left edge, right edge, and centerline cuts.

**Electrical Metal Shears:** Used for general metal cutting, such as at the hips and valleys.

*Note:* Some erectors prefer to use circular power saws with metal cutting abrasive blades. While the use of power saws may be faster, there are some disadvantages that must be considered:

- (1) The edges of metal that have been saw cut are jagged and unsightly, and are more likely to rust than sheared edges.
- (2) Saw cutting will leave small particles of metal on the panel surface that will rust and damage the panel finish if not completely removed.

**Chalk Line:** Used to assist in the alignment of panels, flashings, etc.

**Neoprene Mastic Tape:** 1/16" x 1/4" roll of tape used for installation of inside and outside profile closures and panel side laps.

**Butyl Mastic Tape:** 1/16" x 1/2" roll of tape used for prevention of water infiltration in flashing to sheet metal applications and Super-Span® panel-to-panel sidelaps.

**Caulk:** Butyl or urethane sealant used to inhibit water infiltration.

**Caulking Gun:** For miscellaneous caulking and sealing to inhibit water infiltration.

**Blind Rivet Hand Tool:** Used for miscellaneous flashing and trim applications.

**Marking Tools:** Indelible markers, pencils, or scratching tools.

**Scratch Awl:** Used to mark the steel.

**Utility Knife:** Used for miscellaneous cutting.

**Electric Drill:** Used to drill holes such as those required for rivet installation.

**String Line:** Used for general alignment and measuring.

**Tape Measure:** 25 foot minimum (another 50 ft. is handy).

**Locking Pliers:** Standard and "Duckbill" style for miscellaneous clamping and bending of parts.

## Light Gauge Metal Roof and Wall Panels

Installation Guide for Delta Rib, Delta Rib III, Nor-Clad®, Strata Rib® & 2½ Corrugated



### Delivery, Handling and Storage

- Always check the shipment upon delivery. Check for damage and check material quantities against the shipping list. Note any damaged material or shortages at the time of delivery.
- Handle panel bundles and individual panels with care to avoid damage. Longer bundles and panels may require two or more “pick points” properly spaced to avoid damage that can result from buckling and/or bending of the panels. Request a copy of the Long Length Handling Instructions and diagrams from ASC Building Products customer service as required.
- Store the panels and other materials in a dry, well ventilated area and away from traffic. Elevate one end of the bundle so that any moisture that may have accumulated during shipping can run off. Be sure that air will be able to circulate freely around the bundles to avoid the build-up of moisture. Never store materials in direct contact with the ground.
- Wear clean cotton gloves when handling unpainted Zinalume®-coated panels or flashings to avoid discoloration. Rollforming die marks (which appear black), particularly at bends, will be visible.
- Wear clean, non-marking, soft soled shoes when walking on the panels to avoid shoe marks or damage to the finish. Do not step on the panel seams or ribs. Step only in the flat area of the panel.

### Safety Considerations

- **Never use unsecured or partially installed panels as a working platform**  
Do not walk on panels until they are in place on the roof and all of the fasteners attaching the panels to the roof have been installed.
- **Metal roofing panels are slippery when wet, dusty, frosty or oily**  
Do not walk on a metal roof when any of these conditions are present. Wearing soft soled shoes will help minimize slipping and help prevent damage to the painted surfaces.
- **Do not walk on the panel seams or major ribs**  
When walking on the fully installed roof panels, be sure to step only in the flat areas of the panels.
- **Always be aware of your position on the roof relative to your surroundings.**  
Take note of the locations of roof openings, roof edges, equipment, co-workers, etc.
- **Always wear proper clothing and safety attire.**  
Wear proper clothing when working with sheet metal in order to minimize the potential for cuts, abrasions, and other injuries. ASC Building Products recommends safety glasses and gloves.
- **Use care when operating electrical and other power equipment.**  
Observe all manufacturer’s safety recommendations.
- **Roof installation on windy or stormy days can be dangerous.**  
Avoid working with sheet metal products on windy or stormy days.

## Roof Preparation

ASC's Light Gauge Roofing can be used in both new construction and retrofit roofing applications. We recommend the installation of Light Gauge Roofing over a continuous rigid substrate such as plywood, wood decking, or over intermittent supports. Contact ASC for additional information.

The following steps need to be taken to prepare the roof for installation of Light Gauge Roofing panels:

### New Roofs

1. Make sure there are no nails or other objects protruding from the substrates that might puncture the underlayment or the roof panels. Clean all debris from the roof.
2. Check all details for possible roof penetrations which must be added to the deck prior to roof panel installation.
3. Cover the entire roof deck with a minimum of 30 lb. asphalt-saturated felt paper. For applications over spaced framing other types of moisture barriers may be required. Begin at the eave and roll the felt horizontally (parallel to the eave). Allow each consecutive course to overlap the previous one 3 inches. Overlap the end a minimum of 6" when starting a new roll of felt. Areas of felt paper that have been torn or cut should be replaced or repaired prior to installation of the metal roof. (See *illustration #1*).

*Note:* In areas where snow, ice, and heavy rain conditions exist, a high temperature cold-applied rubberized underlayment should be used in lieu of felt in the valleys. Felt on the remainder of the roof will lap over the membrane where the two meet. See *Valley page 16*.

4. Place an alignment line along the gable end where the first roof panel will be installed. **This line must be parallel to the gable edge of the roof deck and square with the eave line.** Check the roof for squareness by making a 3' line across the eave. (See *illustration #2*). Completing the 3' x 4' x 5' triangle should place the 4' edge of the triangle parallel with the gable. The first roof panel will be placed parallel with this line. Slight variations or out-of-square conditions up to 3" can be covered by the gable trims shown on page 21.
5. It is very important to measure the entire length of the roof from gable to gable. Correct placement of the panels will allow the panel's ribs on each side to be covered by the gable flashing shown on page 21. This will create a symmetrical appearance on both gables. Should this be impractical, the adjustable gable detail on page 32 can be used.

**ILLUSTRATION #1**

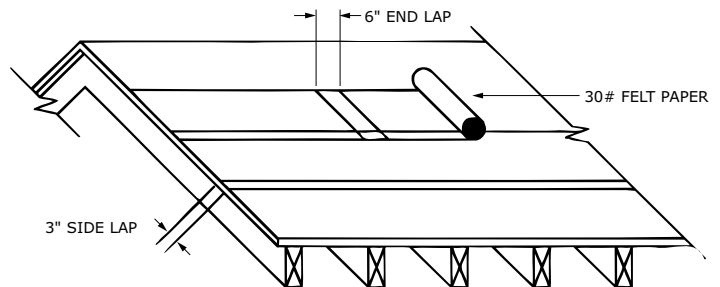

**ILLUSTRATION #2**

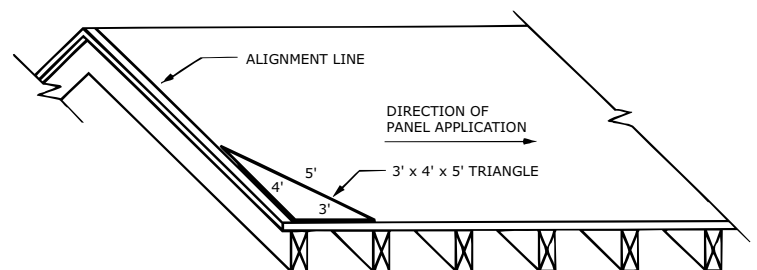

# Light Gauge Metal Roof and Wall Panels

Installation Guide for Delta Rib, Delta Rib III, Nor-Clad®, Strata Rib® & 2½ Corrugated



## Roof Preparation

### Existing Roofing:

Some jurisdictions will allow reroofing over existing roofing without the need for tearoff. Check with your local codes or building department for your specific requirements.

For best results, Light Gauge Roofing requires a relatively smooth and flat substrate. Application over rough and/or uneven surfaces is not recommended, for example, wood shingles.

If the roof is to be stripped down to the existing decking, follow the procedures for new roofs on page 5. Be sure to check the existing roof and repair any damaged areas prior to installation of the new roof system.

*Note:* Do not apply Light Gauge Roofing over roofs with structural damage or trapped moisture.

### The following steps should be taken when installing ASC's Light Gauge Roofing over existing roofing:

1. Inspect the roof for damage and make the necessary repairs to achieve a flat plane for the metal roof panels. Wood shingles should be removed.
2. Secure any warped or loose roofing.
3. Make sure that there are no nails or other objects protruding from the roof that might puncture the new underlayment or the new roof panels.
4. Remove all moss and other debris from the roof.
5. Cut off any overhanging roofing flush with the roof deck and remove all hips, ridge caps, and penetration flashings.
6. Metal debris/shavings should be removed from the roof progressively and daily to prevent immediate corrosion and scratching of the top coat.
7. Follow the directions on page 5, #2 through #5 on roof preparation.

## Map of Typical Roof Conditions

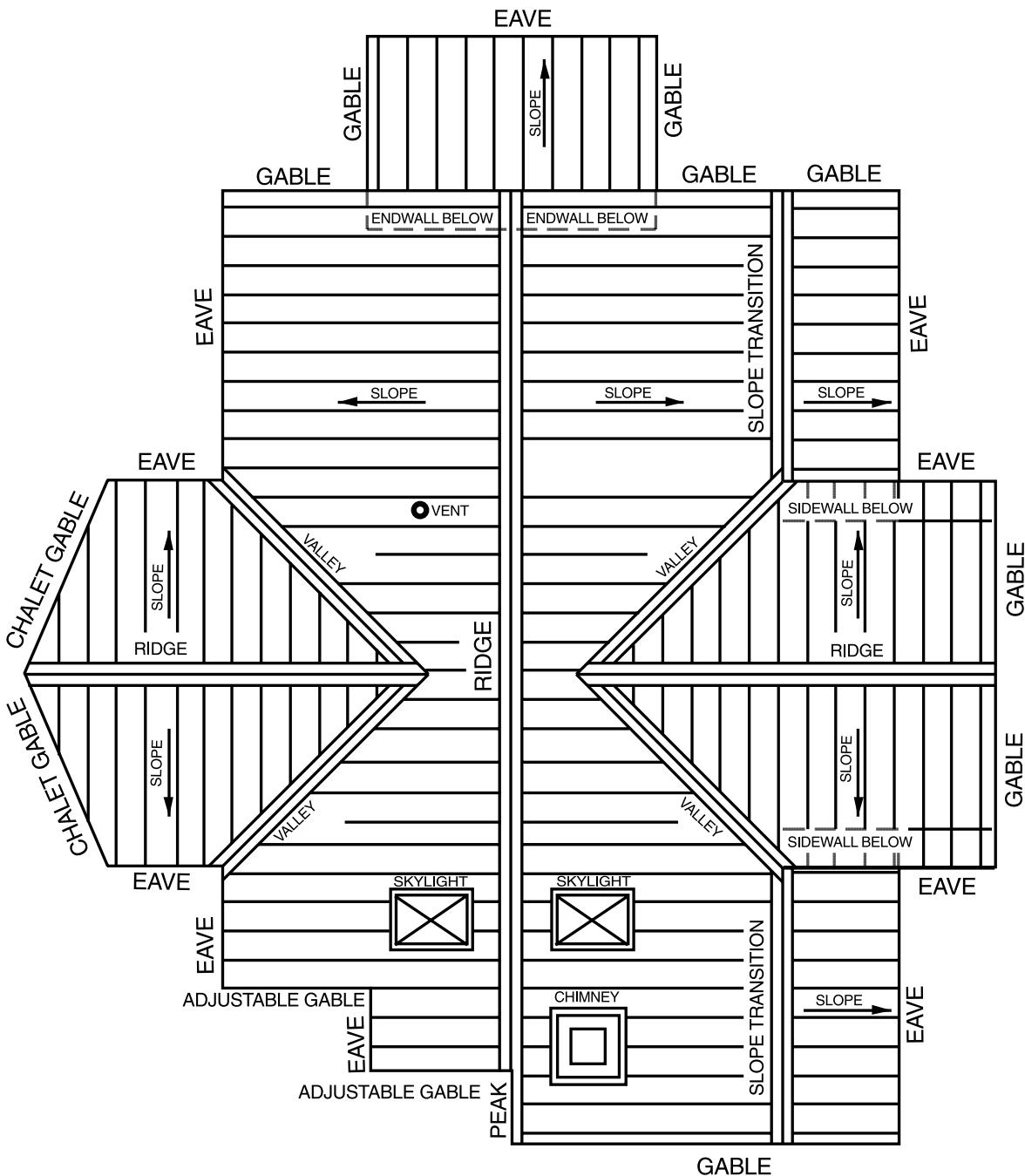

For suggestions on how to trim flashings in the different areas, please refer to the following pages:

<b>Flashing</b>	<b>Page</b>	<b>Flashing</b>	<b>Page</b>	<b>Flashing</b>	<b>Page</b>
Adjustable Gable . . . . .	32	Gable . . . . .	13, 15, 21-24	Sidewall Flashing . . . . .	26
Chalet Gable . . . . .	31	Gutter . . . . .	20	Skylight . . . . .	35-39
Chimney . . . . .	40-43	Peak . . . . .	25	Valley . . . . .	16-17, 44-45
Eave . . . . .	18-19	Pitch Transition . . . . .	29-30	Vent . . . . .	33-34
Endwall . . . . .	27-28	Ridge . . . . .	12, 14		

# Light Gauge Metal Roof and Wall Panels

Installation Guide for Delta Rib, Delta Rib III, Nor-Clad®, Strata Rib® & 2½ Corrugated



## Trim Locations

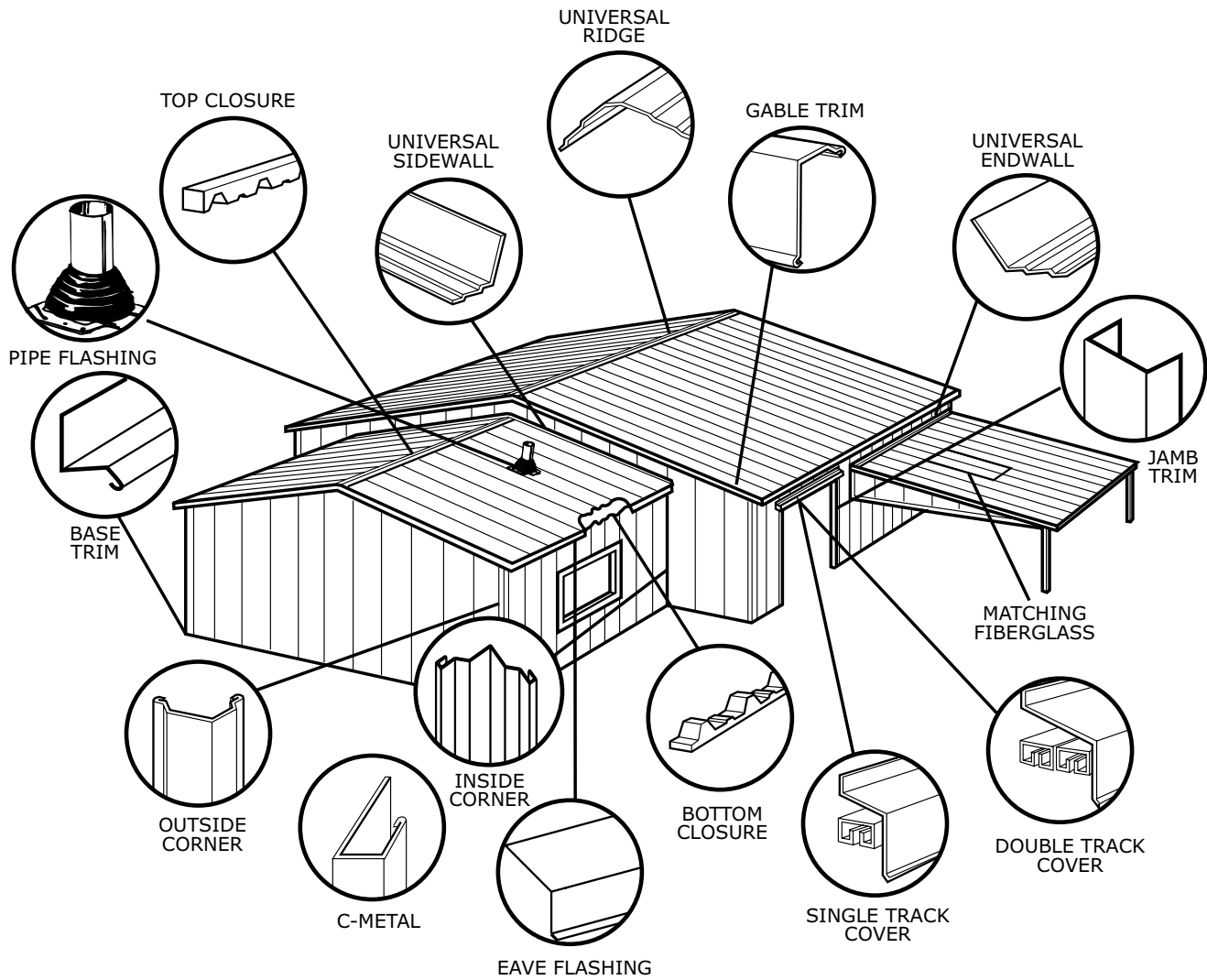



## Fastener Placement

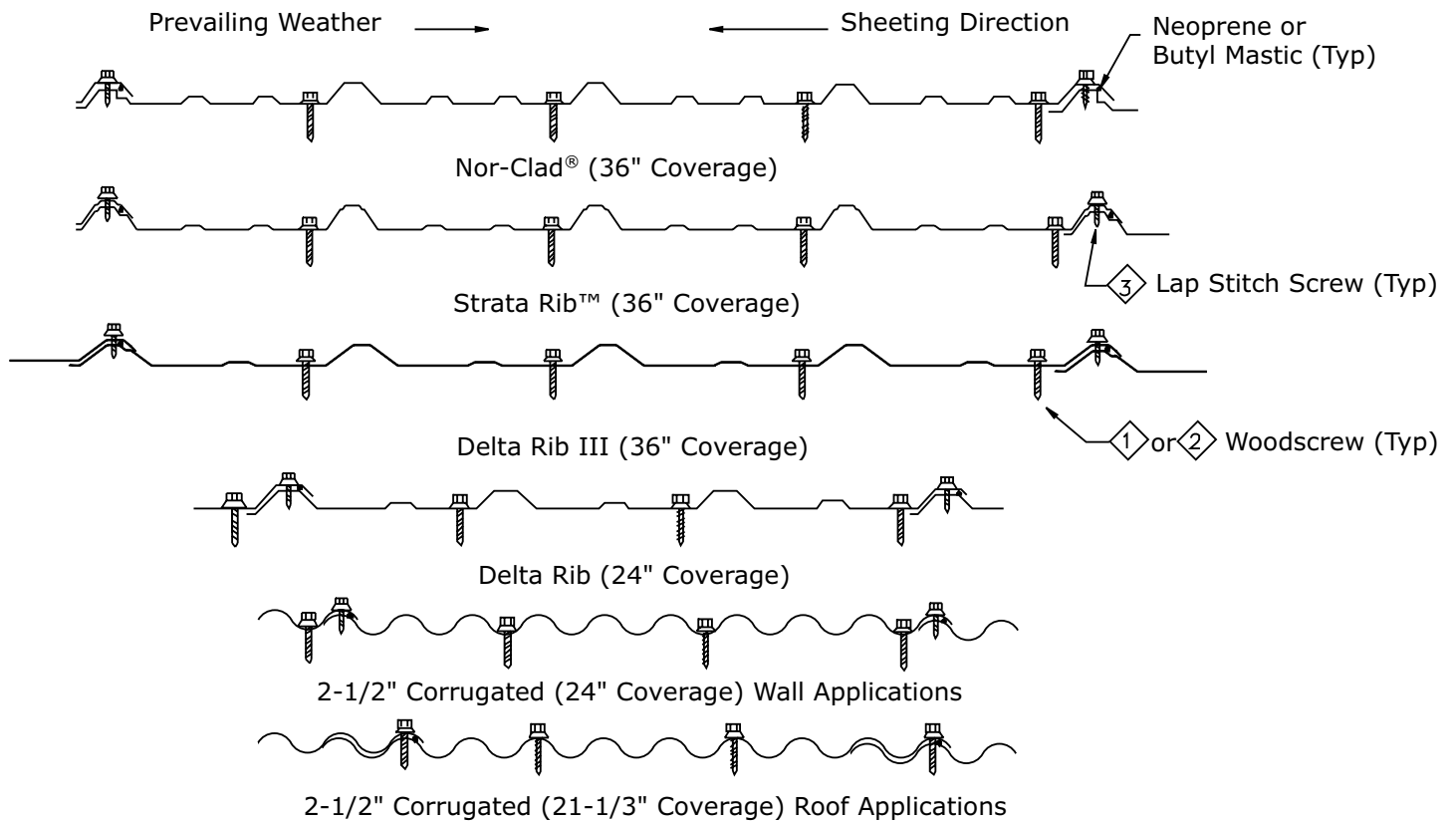

MAXIMUM RECOMMENDED FASTENER ROW SPACING	
1/2" Plywood	24"
5/8" Plywood	36"
2" x 4"	36"

Note: 1) Lap panels away from prevailing weather. Use only those accessories specifically designed for use with this product. Use only galvanized or Zinalume®-coated fasteners. Isolate roofing and flashings from contact with dissimilar metals. Fastener selection will vary based upon substrate. The use of neoprene or butyl mastic tape along the sidelaps, as shown above, is always recommended for roofs. Lap stitch screws should be placed @ 16" o.c. maximum.













Note: 2) The maximum recommended fastener row spacing applies to mild weather conditions of 80 mph winds and an exposure rating of "B" (protected) for typical buildings and substrate. For project specific wind uplift attachment, contact your ASC representative.

# Light Gauge Metal Roof and Wall Panels

Installation Guide for Delta Rib, Delta Rib III, Nor-Clad®, Strata Rib® & 2½ Corrugated



## Fastener Selection

Fastener #	Description	Use
	 No. 9 x 1", 1-1/2", 2", 2-1/2", 3" Wood Screw 1/4" Hex Head	Panel to dimensional lumber
	 No. 14 x 1", 1 1/2" Wood Screw 5/16" Hex Head	Panel to plywood min. 1/2" thick.
	 No. 12 x 3/4" Stitch Screw 1/4" Hex Head (compatible with No. 9 Wood Screw)	Trim and side lap attachments.
	 No. 14 x 7/8" Lap Self Driller 5/16" Hex Head (compatible with No. 14 Wood Screw)	Trim and side lap attachments.
	 STST-42 Stainless Steel Rivet 1/8 x 1/8	Trim-to-trim or trim-to-panel attachments.
	 No. 12 x 1", 1 1/2", 2", 2 1/2" Self Driller 5/16" Hex Head	Panel to purlin or deck attachments

### Notes

- The table above shows the Light Gauge panel fasteners provided by ASC Building Products. Refer to the panel installation, flashing details, and fastener placement pages of this manual for specific fastener usage. See page 9 for fastener spacing.
- Panel attachment screws must be long enough to penetrate through the roof decking at least 3/8", or penetrate solid lumber at least one inch.
- All screws must be coated to provide protection against corrosion.
- Exposed fasteners should have sealing washers and be the same color as the parts they attach.
- Roofing nails will also be required, but are not furnished by ASC. They are typically used to temporarily hold a flashing in place that needs to be installed prior to panels.

- Screws must be properly driven to ensure proper seal and holding strength. Do not under drive or overdrive the screws. Recommended drill speed is 2000 rpm. Use of a depth-sensing nosepiece will aid in properly driving screws.

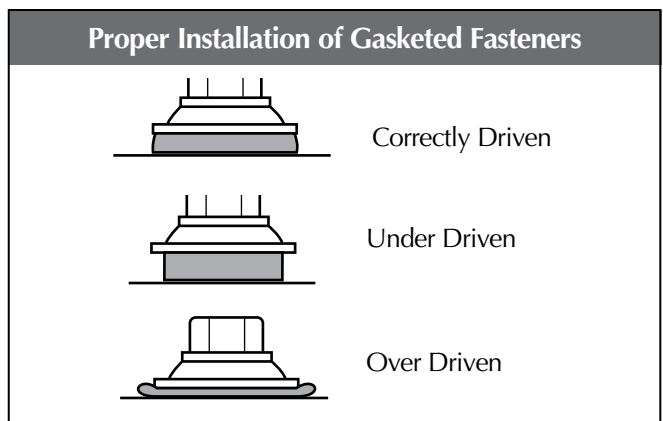

## Panel Installation

### GENERAL

Study the details section of this manual prior to the installation of the panels. Pay close attention to the following:

- Flashings that need to be installed prior to the panels include Valley, Eave, Vented Eave, Adjustable Gable and Chalet Gable.
- Apply sealant or mastic tape to the pre-installed flashings as shown in the detail section of this manual.

### PROCEDURE

1. Install eave trim, valley trim and inside closure prior to panel installation.
2. Align the edge of the first panel with the alignment line constructed along the start gable. (See page 5, item 4 and illustration #3 below.) Allow the panel to overhang the eave 1" minimum.
3. Check the downhill end of the panel. If the panel length is correct, the panel should overhang 1" past the eave trim as shown below in illustration #4. Also, the panel should not extend past the centerline of the ridge. (See pg. 12.)
4. After the first panel is properly aligned, fasten per the fastener placement and spacing guidelines on page 9.
5. Lay down the second and third panels, checking alignment, making sure they are square. This will ensure that a sawtooth effect at the eave and ridge is avoided.
6. Metal debris/shavings should be removed from the roof progressively and daily to prevent immediate corrosion and scratching of the top coat.

### ILLUSTRATION #3

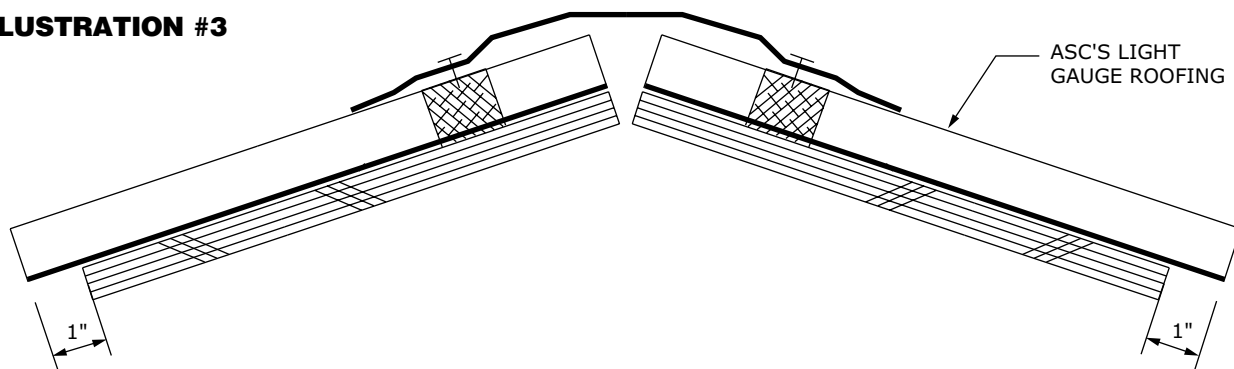

### ILLUSTRATION #4

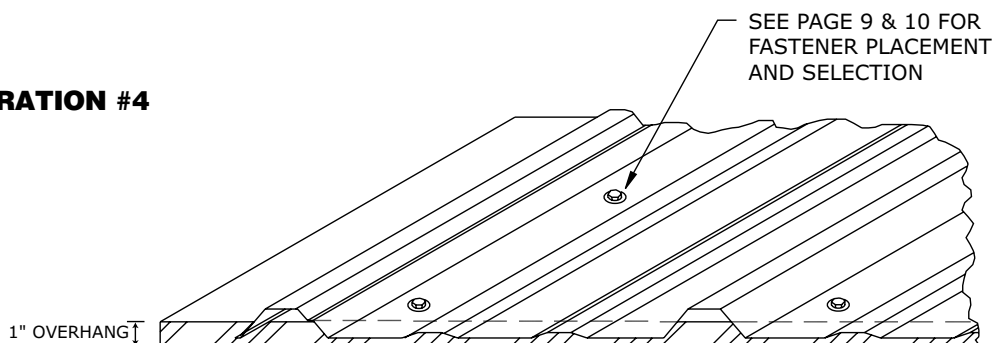

# Light Gauge Metal Roof and Wall Panels

Installation Guide for Delta Rib, Delta Rib III, Nor-Clad®, Strata Rib® & 2½ Corrugated

## Hip/Ridge Flashing

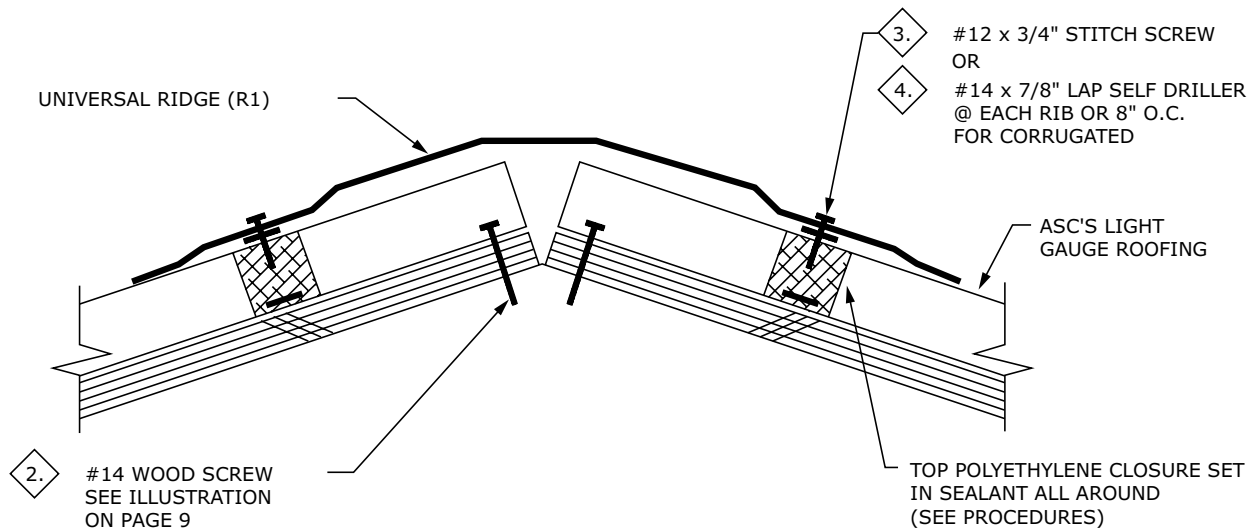
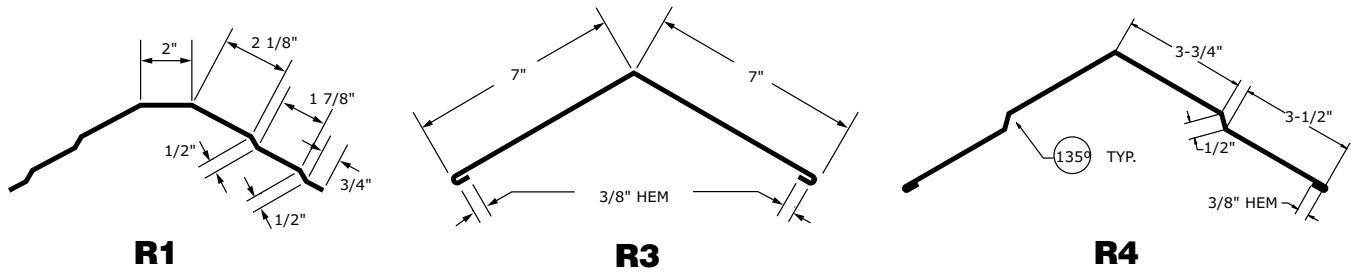

*Note:* The gable flashing must be installed prior to installation of the ridge (see page 21).

### Procedures

- Caulk the bottom and sides of the polyethylene closure. Set the closure as shown above and caulk the top. The closure is optional if the panel is turned up and caulked at the sides near the rib.
- Fasten the ridge cap using stitch screw at each rib or 8" o.c. for corrugated.
- Close the ends of the universal ridge cap by cutting and folding material at each end. Fasten with rivets. (see page 15)
- Caulk, lap and rivet sequential ridge flashings. (see pg. 47).

*Note:* "R1" is a universal hip/ridge. A standard hip/ridge, "R3 & R4", is also available.

## Universal Ridge Termination

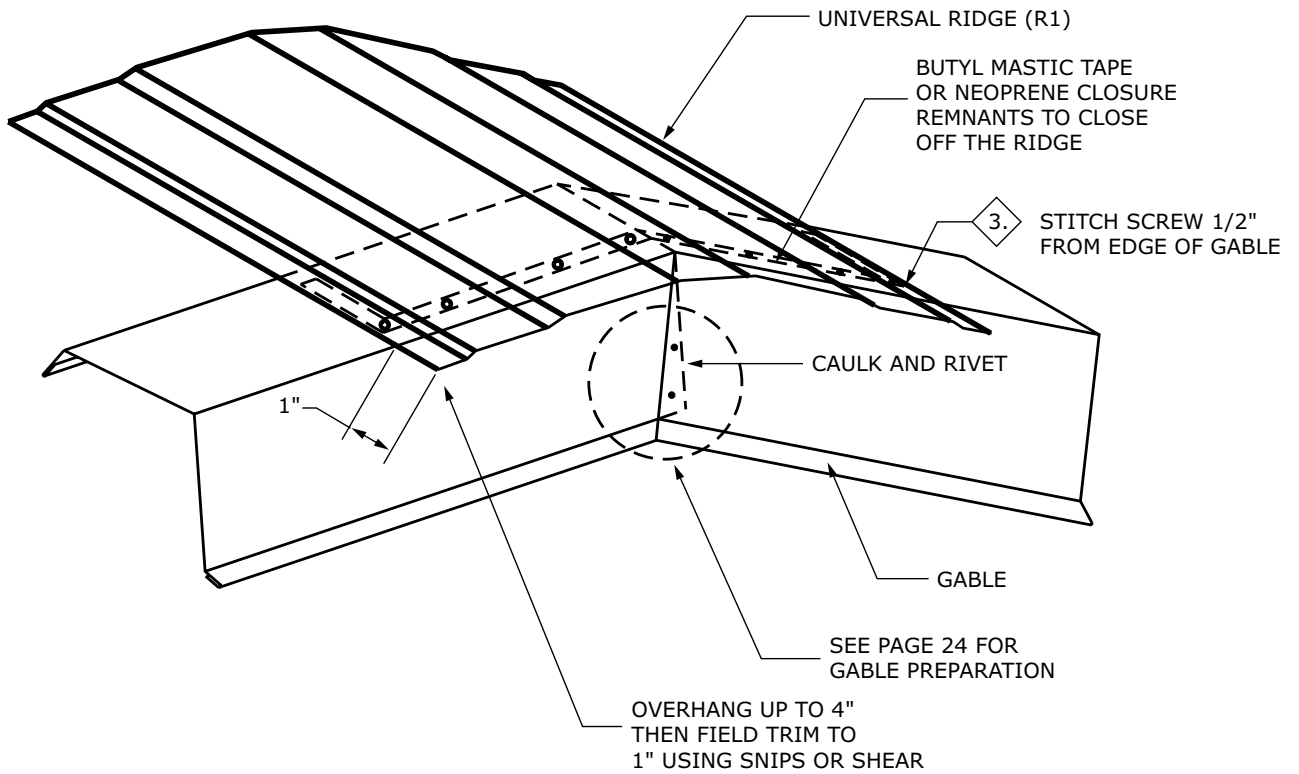

# Light Gauge Metal Roof and Wall Panels

Installation Guide for Delta Rib, Delta Rib III, Nor-Clad®, Strata Rib® & 2½ Corrugated



## Vented Ridge/Hip Flashing

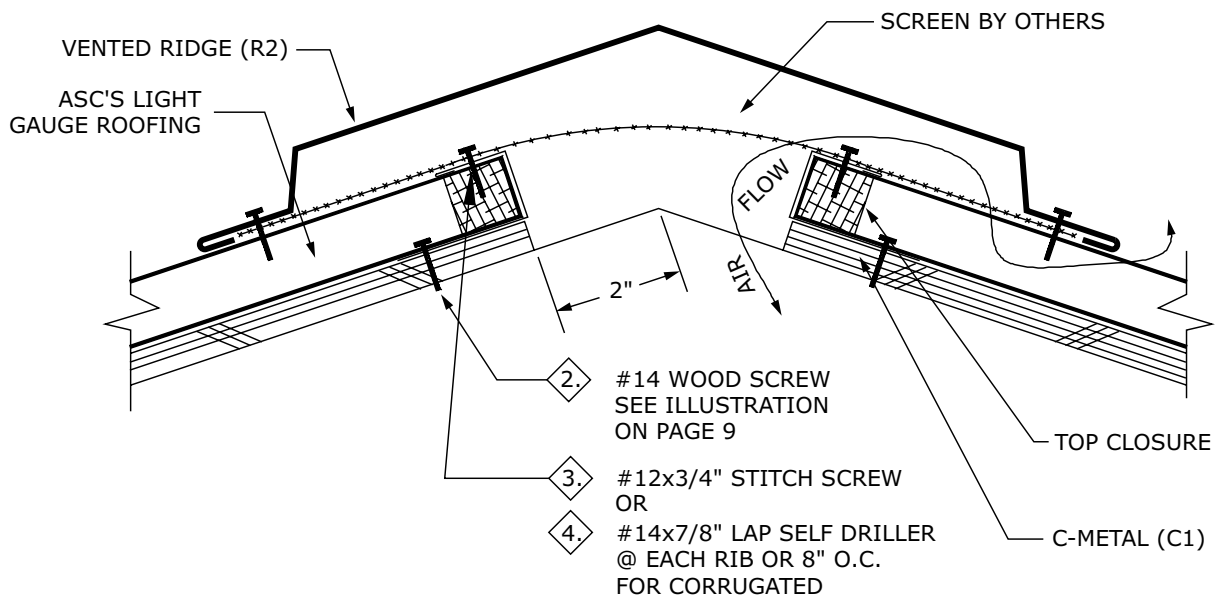
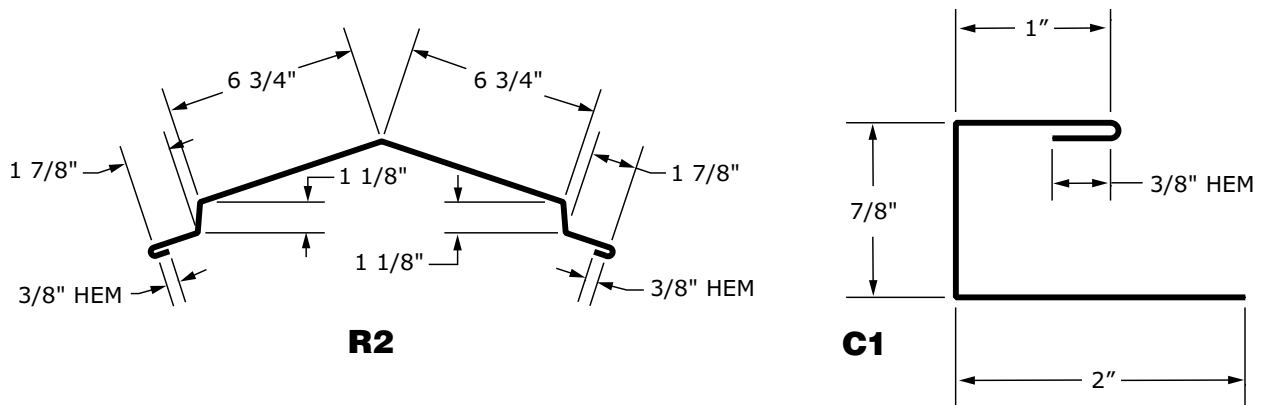

### Procedures

- Plywood should be held back 2" from each side of the ridge.
- Attach the screen at each panel rib sandwiching the top closure in place. Ensure screen is pulled tight to avoid sagging.
- Fasten the vented ridge using stitch screw at each rib or 8" o.c. for corrugated.
- Caulk, lap and rivet sequential flashings. (see pg. 47).
- Close the ends of the ridge cap by cutting and folding material at each end. Fasten with rivets and caulking joints. (see pg. 15).
- Slopes greater than 6:12 may require special ridge dimensions.

*Note:* The gable flashing must be installed prior to installation of the ridge (see page 21).

The screening shown creates a barrier for insects and birds while allowing for ventilation.

For snow and heavy rain environments, please inquire about optional Vented Ridge details.

## Vented Ridge/Hip Termination

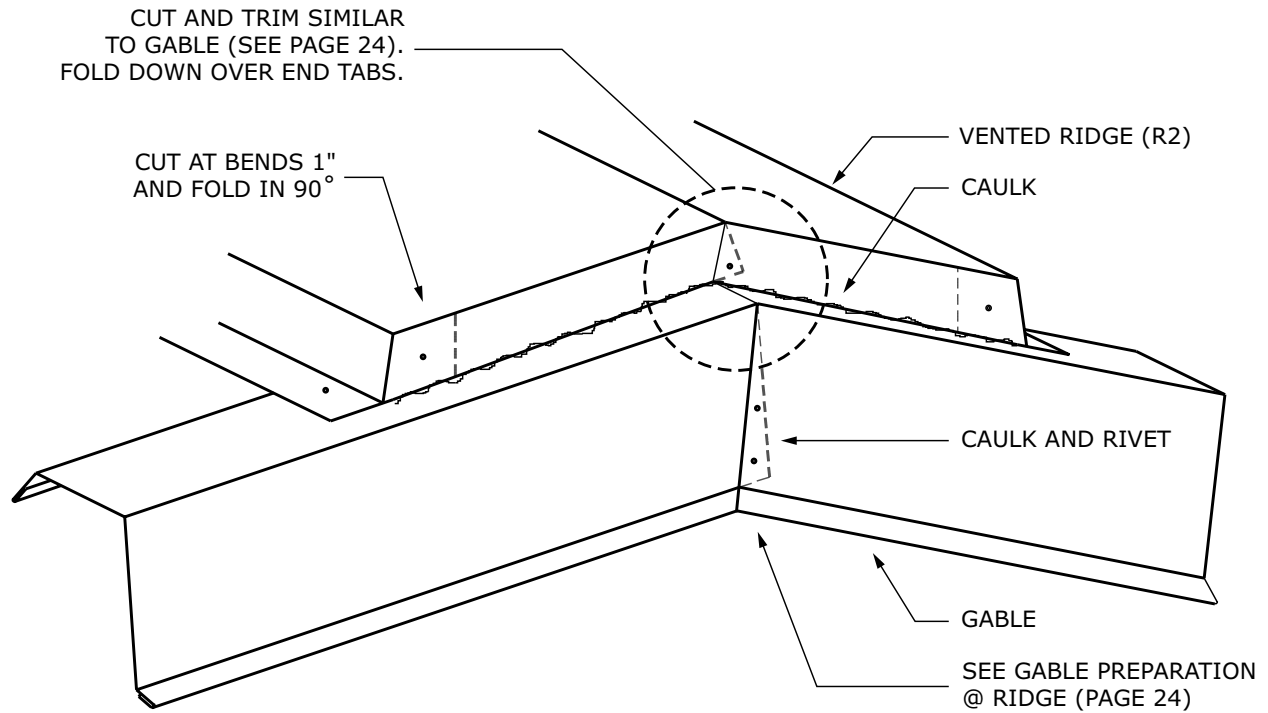

# Light Gauge Metal Roof and Wall Panels

Installation Guide for Delta Rib, Delta Rib III, Nor-Clad®, Strata Rib® & 2½ Corrugated

## Valley Flashing

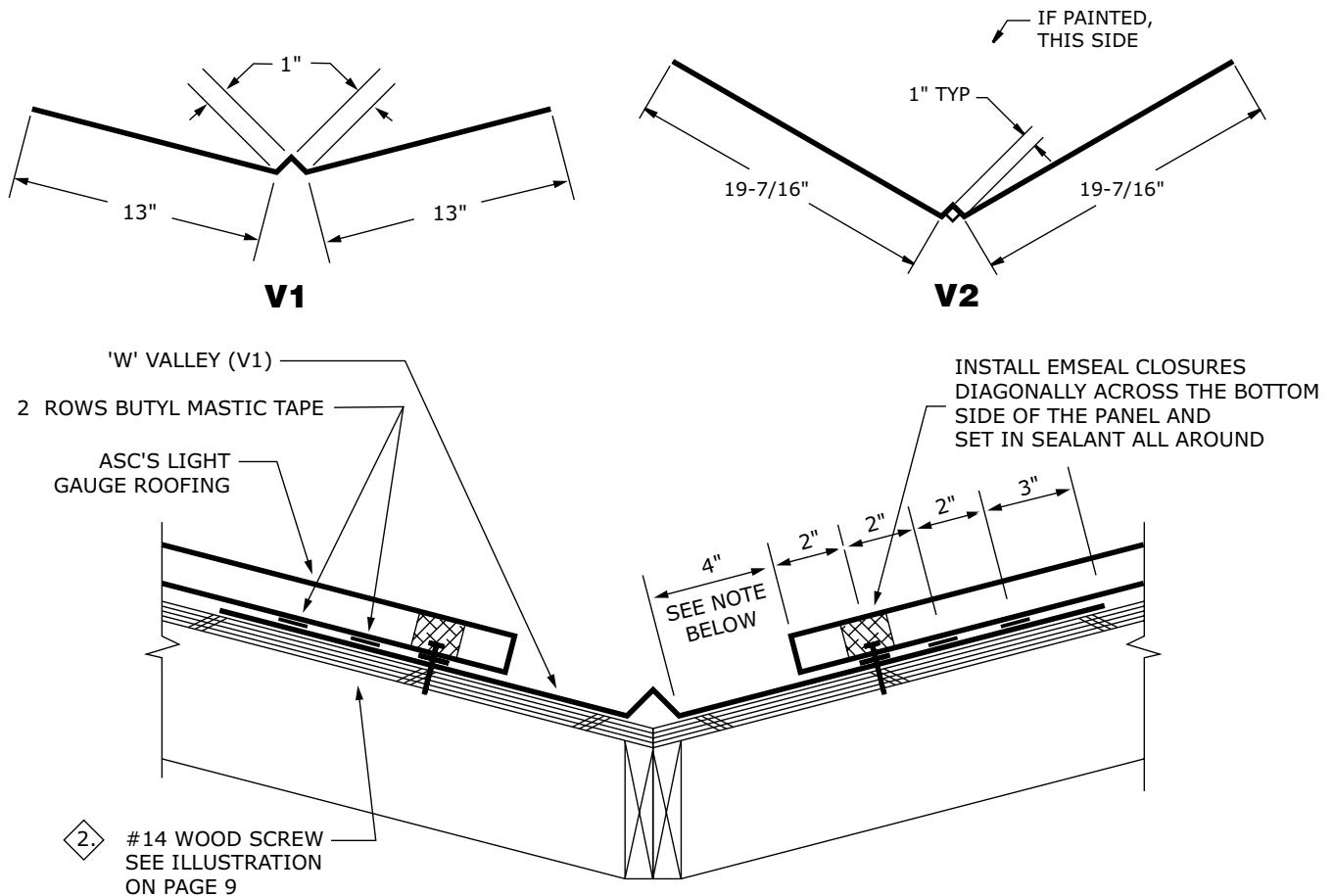

### Procedures

- Place a second layer of 36" roof felt in the valley center line with 18" of roof felt on each side.
- Starting at the low end, trim and place the valley flashing so it overhangs the eaves 1". (see pg. 17.)
- Caulk and lap the subsequent valley flashings a minimum of 8".
- Parallel to the valley, place two rows of 1/2" butyl mastic tape sealant spaced as shown.
- The polyethylene closures cannot be installed diagonally across a panel. At mitre cuts, use emseal closures at a right angle to the panel ribs.
- Field cut the panels holding a minimum of 4" back from the valley as shown. Larger valleys without the center "V", may be required in snow country installations.
- Attach the panels to the roof and 'thru-fasten' along the bottom end using a #14 x 1" woodscrew at 8" up from the valley aligned with the second row of butyl mastic tape.
- When valleys are required, install sidelap neoprene mastic tape along the sidelap a minimum of 10'-0" up from the panel edge.

*Note:* In areas where snow, ice and heavy rain conditions exist, panels may need to be held back more than 4" and the valley flashing overall width must be increased. A high temperature cold-applied rubberized underlayment should be used extending at least 3' up from the center of the valley on each side.



## Valley Termination

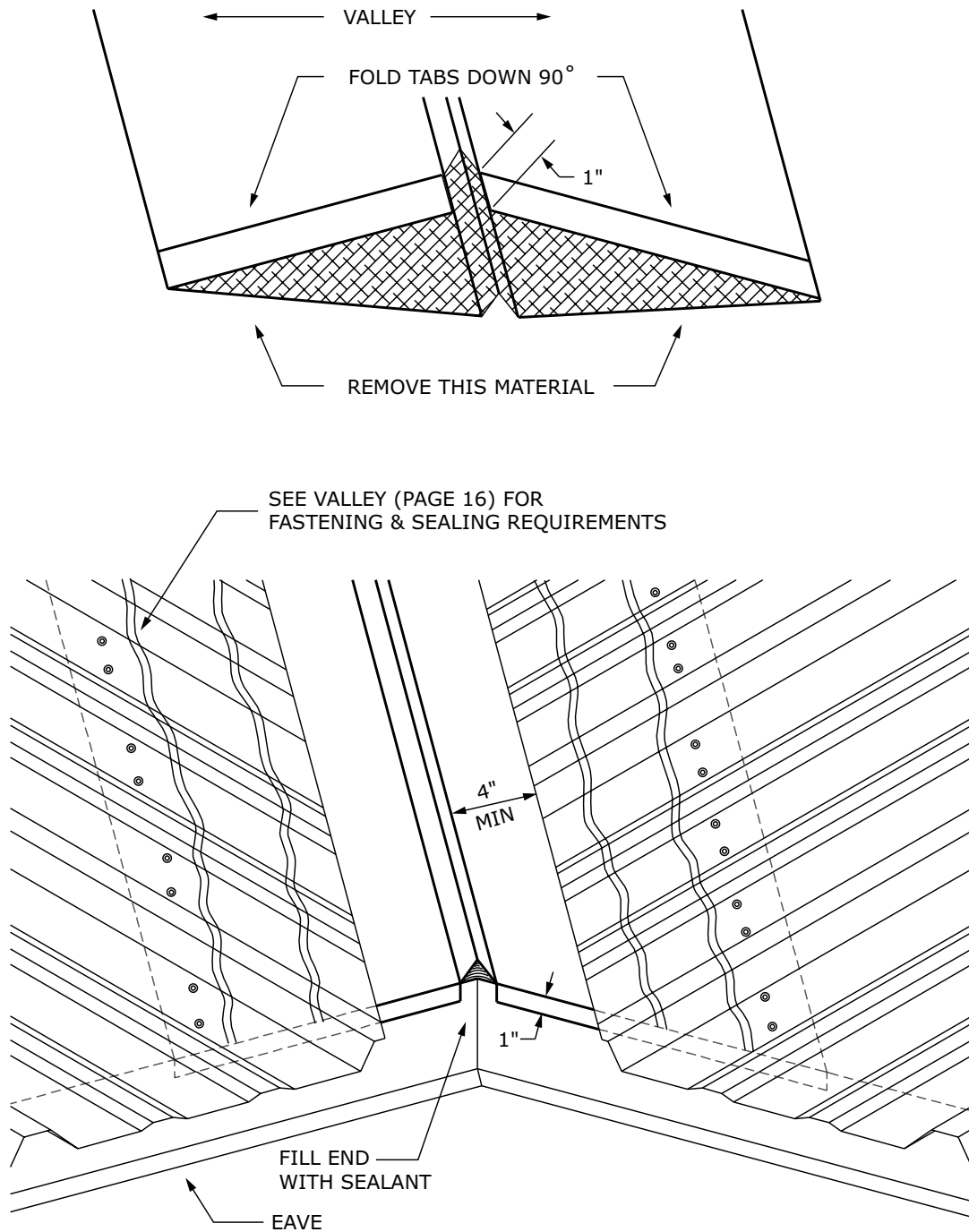

Note: Emseal closures not shown for clarity.

# Light Gauge Metal Roof and Wall Panels

Installation Guide for Delta Rib, Delta Rib III, Nor-Clad®, Strata Rib® & 2½ Corrugated



## Eave and Vented Eave Flashings

This flashing must be installed prior to the panels.

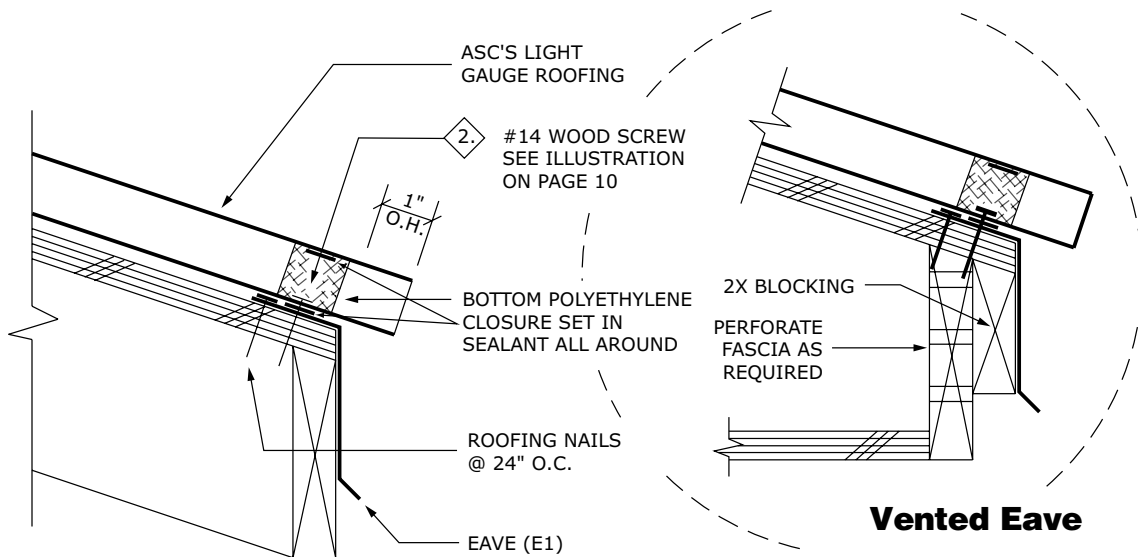
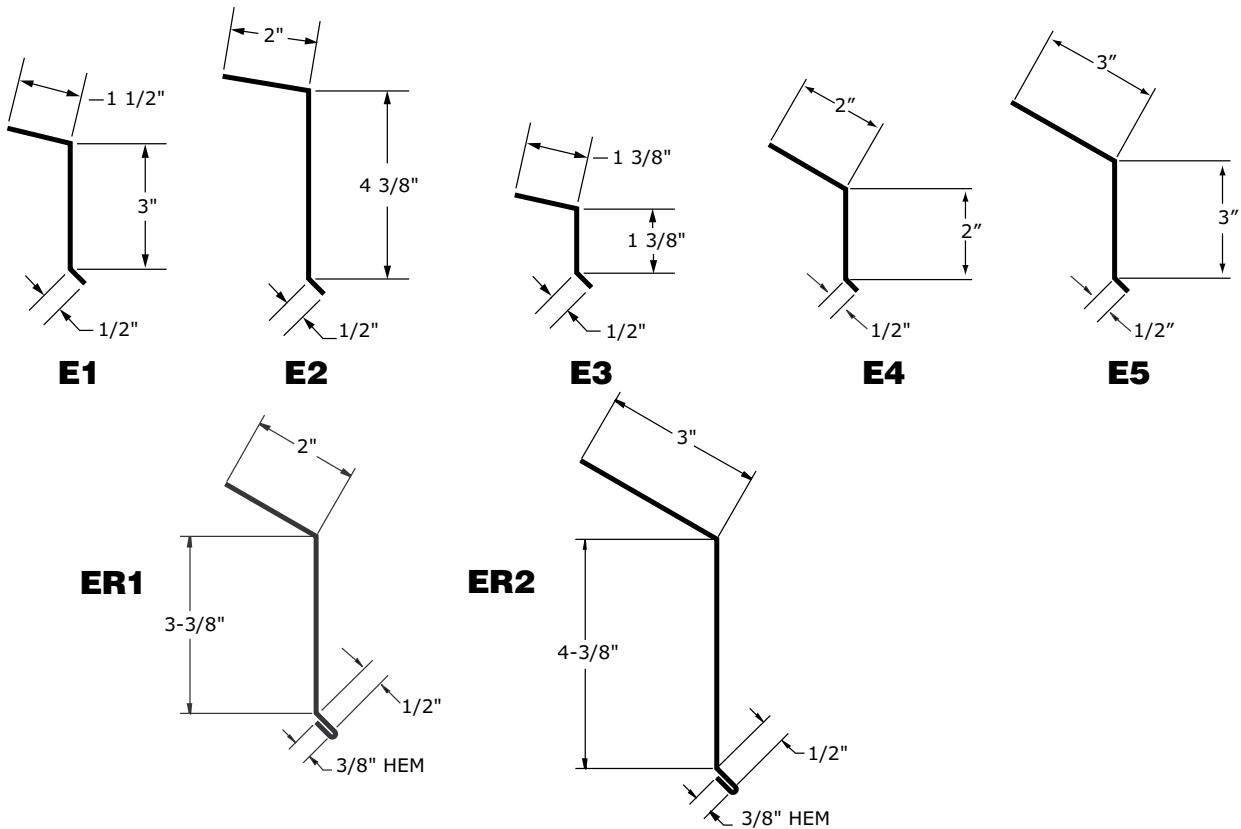

### Procedures

- Carpentry must be completed as indicated prior to installation of the Vented Eave.
- Attach the eave flashing using roofing nails evenly spaced at 24" o.c.
- Caulk and lap the flashing a minimum of 3". (see pg. 47)
- Panels should overhang the eave 1" minimum.

## Eave Flashing Preparation

Use this flashing where eave meets gable

*Note:* Length of eave must allow 1" to extend past gable fascia.

### STEP 1

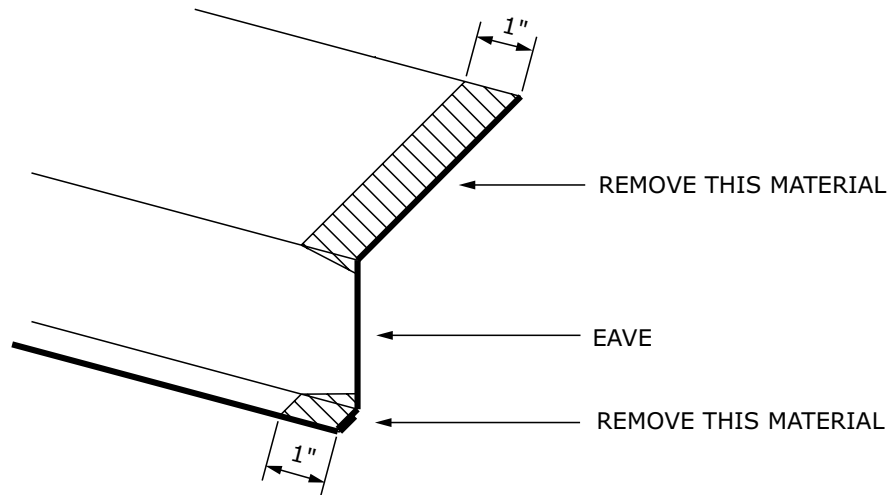

### STEP 2

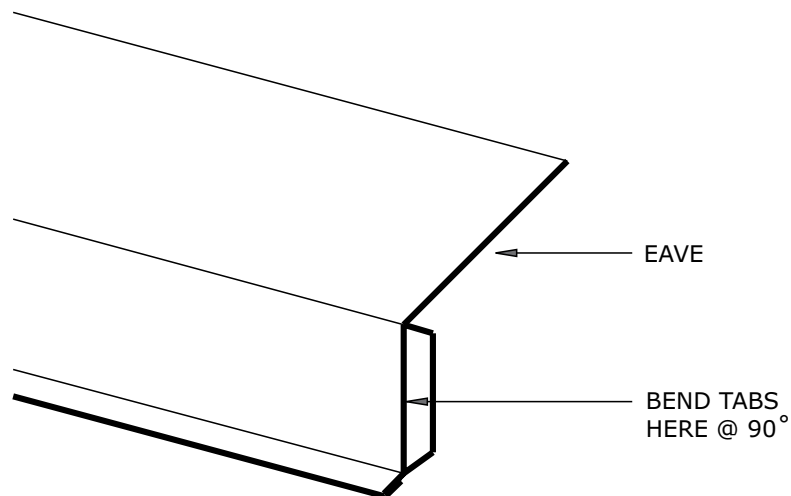

## Light Gauge Metal Roof and Wall Panels

Installation Guide for Delta Rib, Delta Rib III, Nor-Clad®, Strata Rib® & 2½ Corrugated

### Gutter and Vented Gutter Flashings

Note: This flashing must be installed prior to the panels.

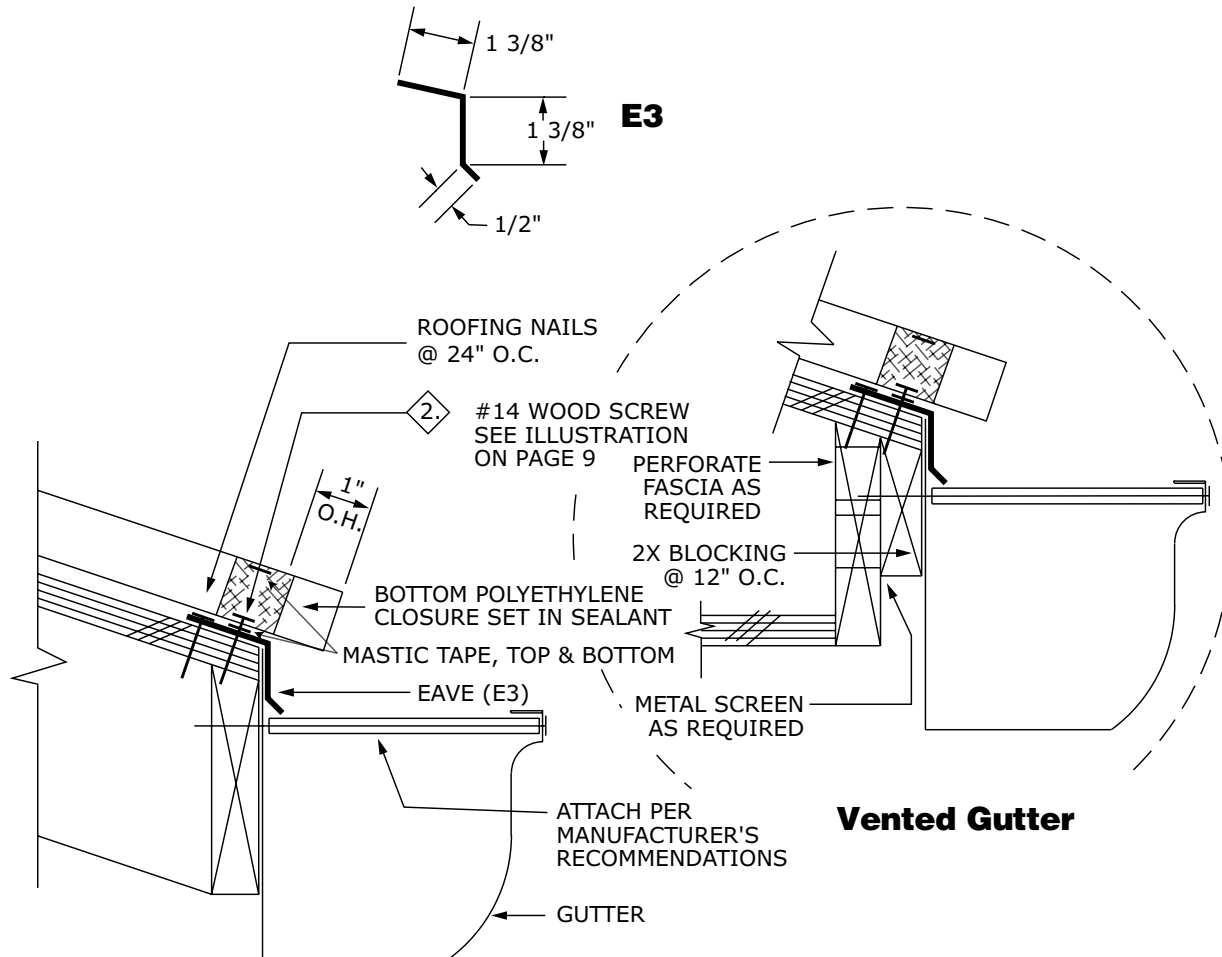

#### Procedures

- Felt should go over top of eave (E3) (felt not shown).
- Carpentry must be complete as indicated prior to installation of the Vented Gutter.
- Attach eave flashing using roofing nails evenly spaced at 24" o.c.
- Caulk and lap the flashing a minimum of 3". (see pg. 47)
- Panels should overhang the eave a minimum of 1".
- ASC Building Products recommends that a licensed gutter contractor install gutters.

## Gable Flashing

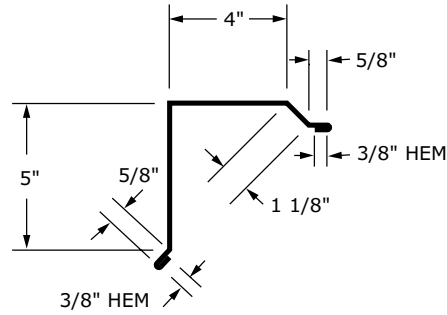

**G1**

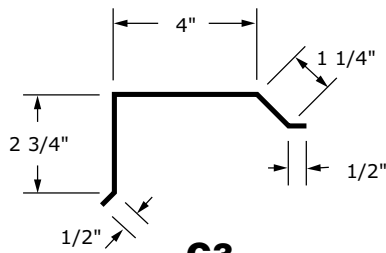

**G3**

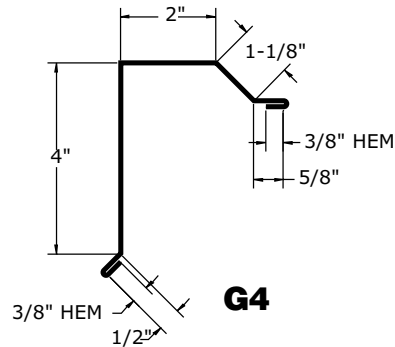

**G4**

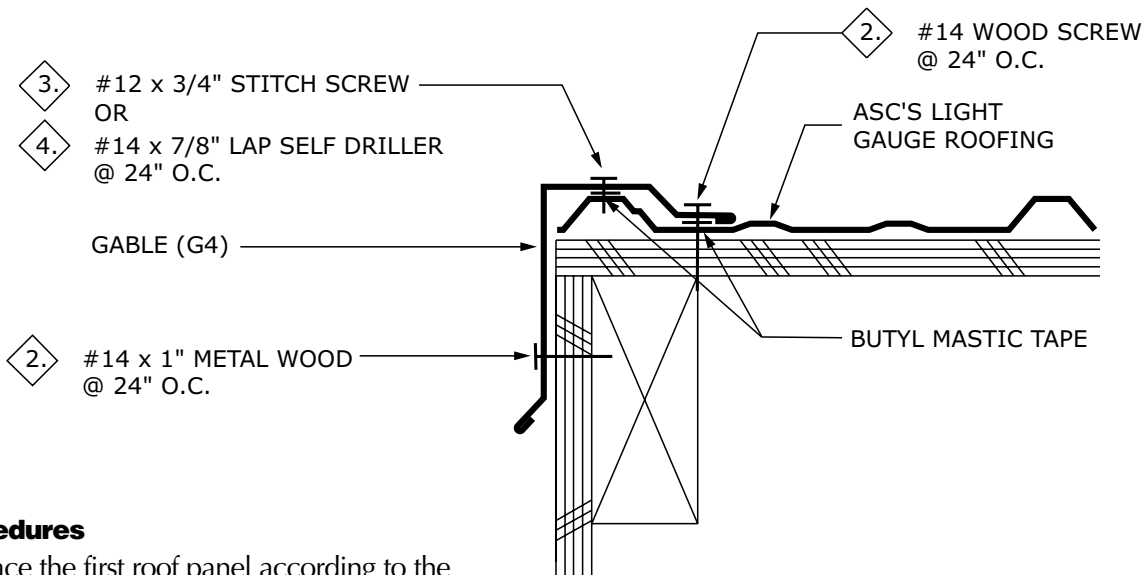

### Procedures

- Place the first roof panel according to the instructions on pages 5-6 and 11.
- Place butyl mastic tape along the top of the panel rib as shown.
- Install the gable flashing by placing it firmly over the rib. Use stitch screws to fasten flashing to the panel and use color matched woodscrews at 24" o.c. to fasten flashing to structure.
- Caulk and lap the flashing a minimum of 3". (see pg. 47)
- Mitre cut the flashing at the peak to join each side at the ridge. (see pg. 24)
- Snip and fold the gable at the eave to close the end. Use rivets to fasten.

Notes: "G1" is a standard gable. Narrower gables, "G3" and "G4", are also available.

# Light Gauge Metal Roof and Wall Panels

Installation Guide for Delta Rib, Delta Rib III, Nor-Clad®, Strata Rib® & 2½ Corrugated



## Gable/Ridge Transition

(similar to Endwall)

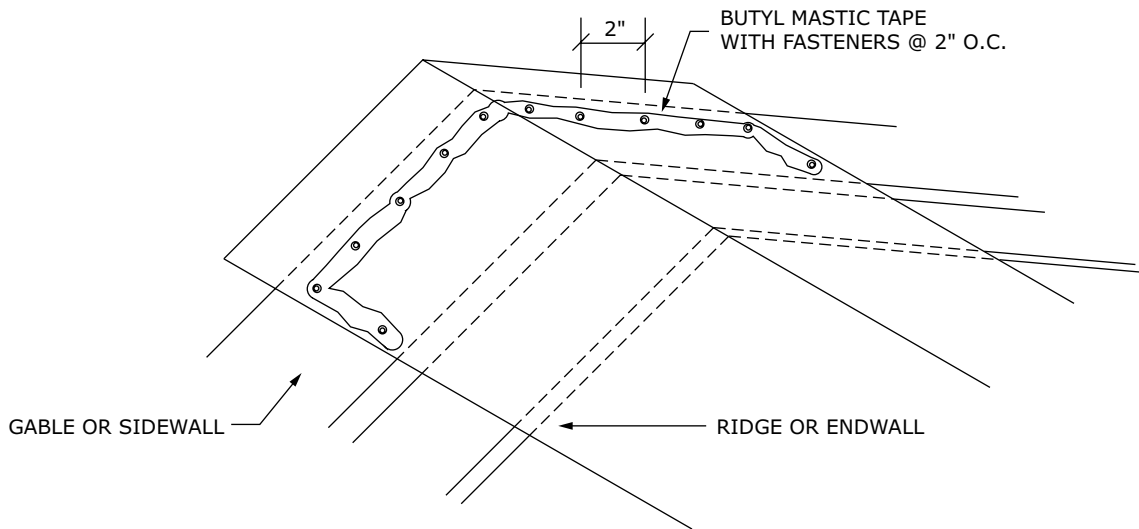

## Gable Corner at Eave

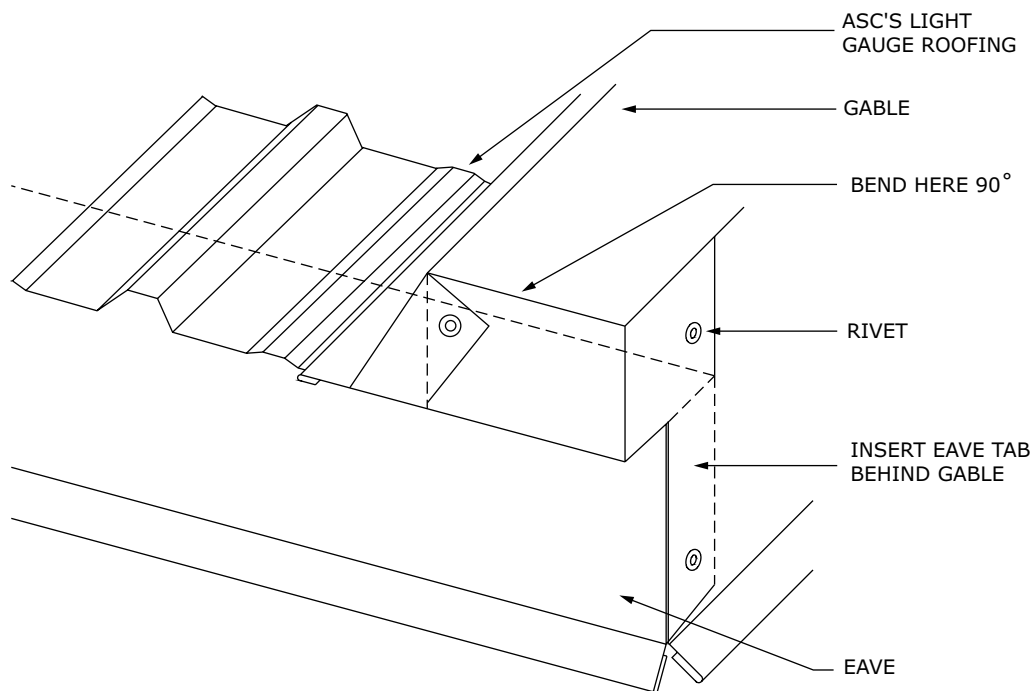

## Gable Flashing Preparation

### STEP 1

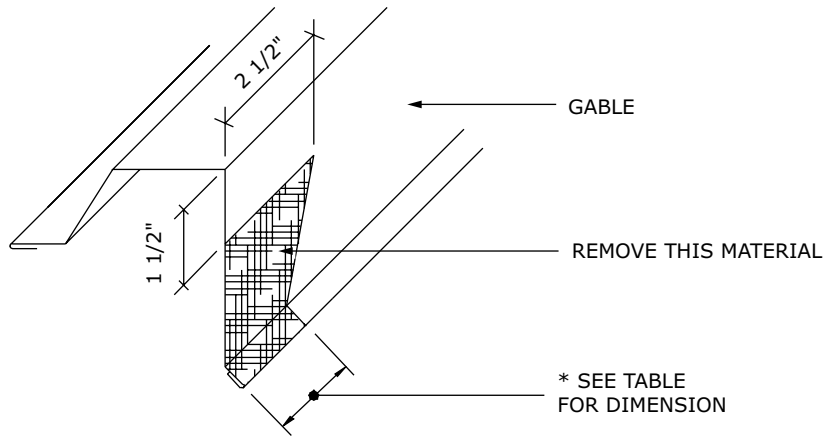

Roof Pitch	Dimension
3:12	2"
4:12	1 7/8"
5:12	1 11/16"
6:12	1 6/16"
12:12	5/8"

### STEP 2

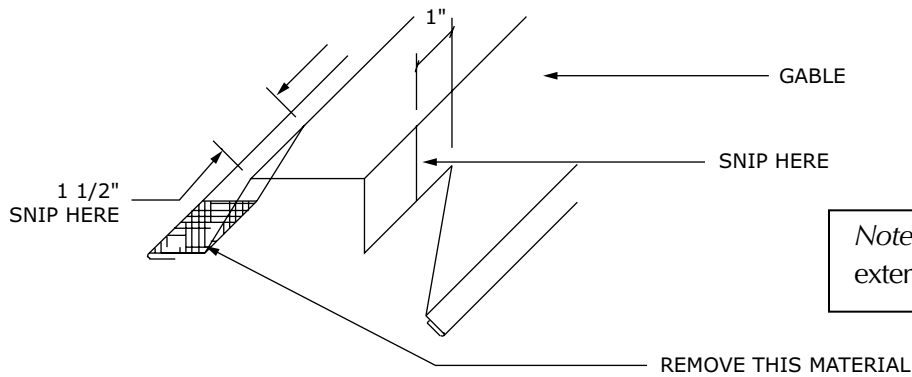

### STEP 3

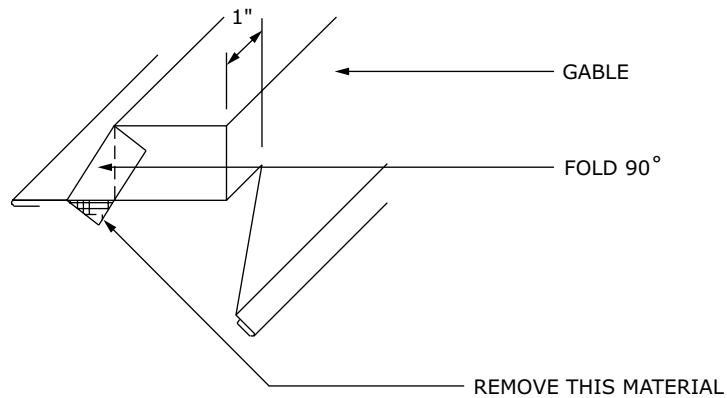

# Light Gauge Metal Roof and Wall Panels

Installation Guide for Delta Rib, Delta Rib III, Nor-Clad®, Strata Rib® & 2½ Corrugated

## Gable Flashing Preparation at Ridge

### STEP 1

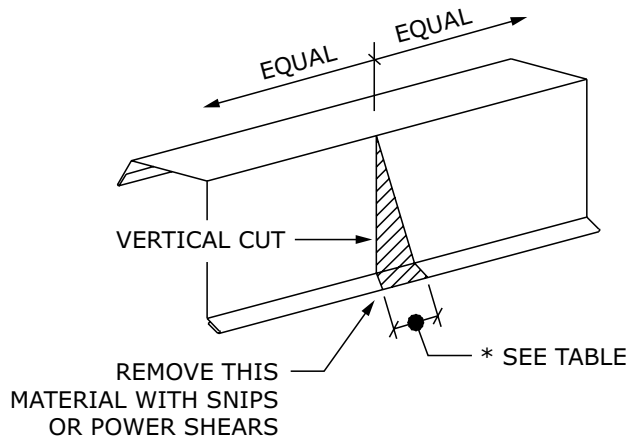

### STEP 2

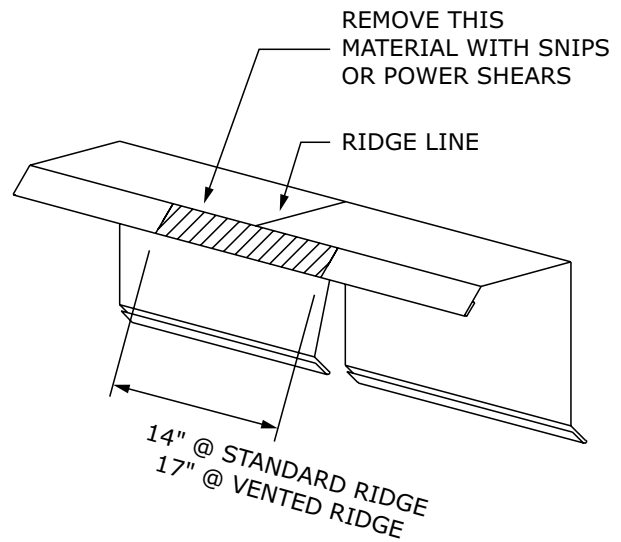

Roof Pitch	Dimension*
3:12	1 <sup>1</sup> / <sub>16</sub> "
3.5:12	1 <sup>1</sup> / <sub>4</sub> "
4:12	1 <sup>7</sup> / <sub>16</sub> "
5:12	1 <sup>3</sup> / <sub>4</sub> "
6:12	2 <sup>3</sup> / <sub>16</sub> "
12:12	4 <sup>7</sup> / <sub>16</sub> "

\* Dimensions only apply to G4 Gable Flashing

### STEP 3

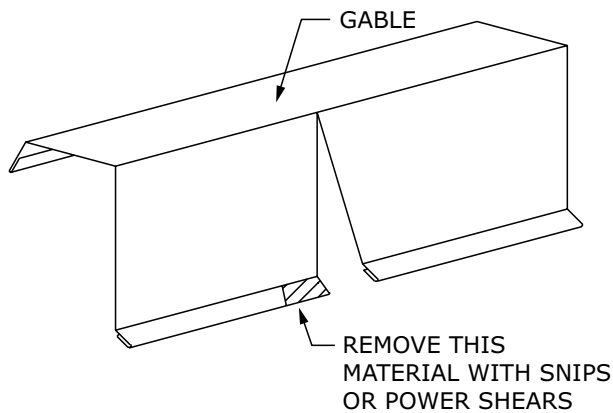

### STEP 4

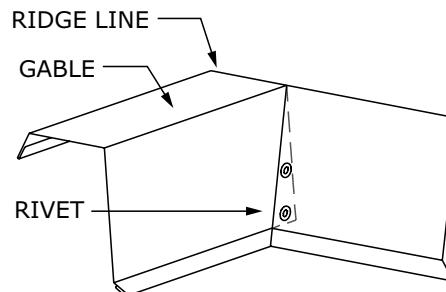



## Peak Flashing

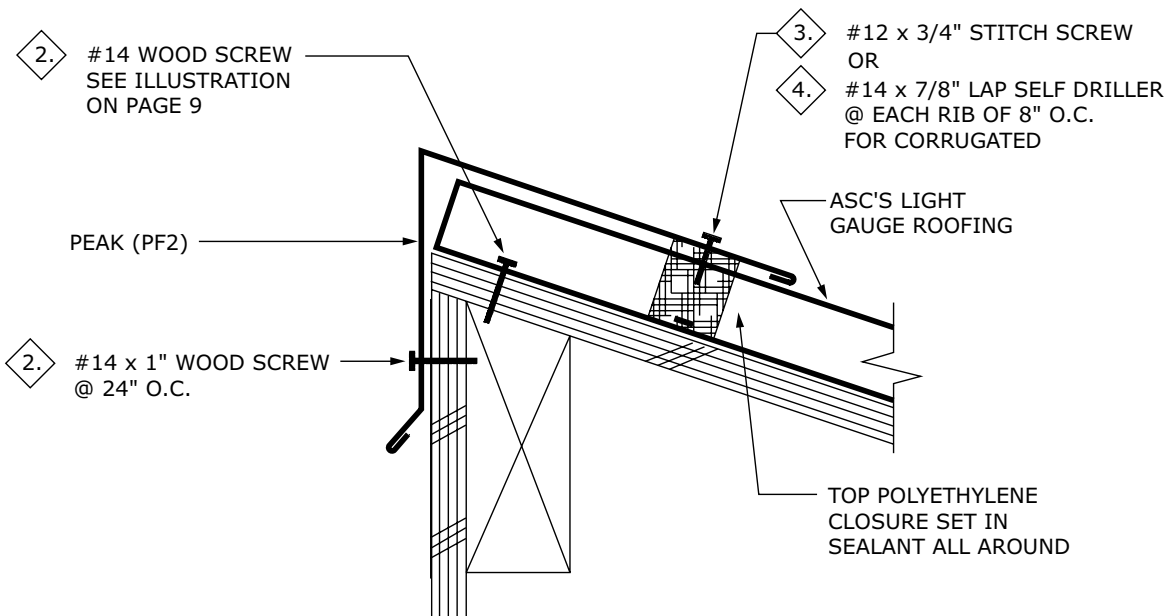
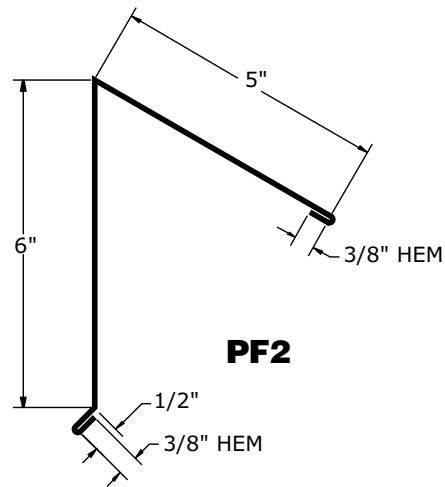

### Procedures:

- Caulk the bottom and sides of the polyethylene closure. Set the closure as shown above and caulk the top. The closure is optional if the panel is turned up and caulked at the sides near the rib.
- Fasten the peak flashing as shown above.
- Caulk and lap the flashing a minimum of 3". (see pg. 47).

# Light Gauge Metal Roof and Wall Panels

Installation Guide for Delta Rib, Delta Rib III, Nor-Clad®, Strata Rib® & 2½ Corrugated

## Sidewall Flashing

This flashing must be installed prior to wall panels.

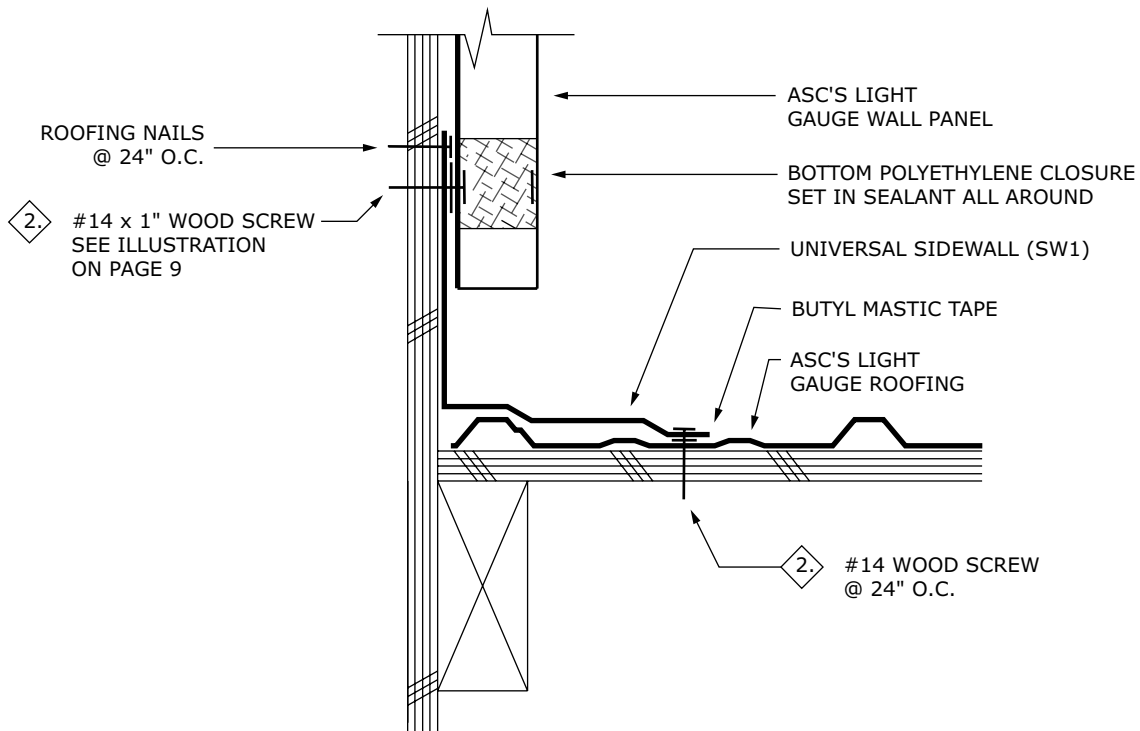
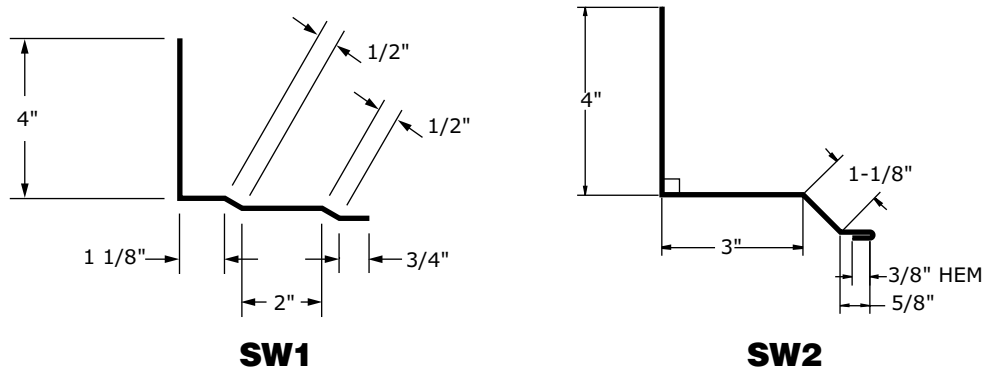

### Procedures

- The roof should be installed prior to the siding.
- Place butyl mastic tape along the top of the panel as shown.
- Install the side wall flashing by placing it firmly on the roofing panel and fastening with the fastener indicated.
- Caulk and lap the flashing a minimum of 3". (see pg. 47.)

## Endwall Flashing

This flashing must be installed prior to wall panels.

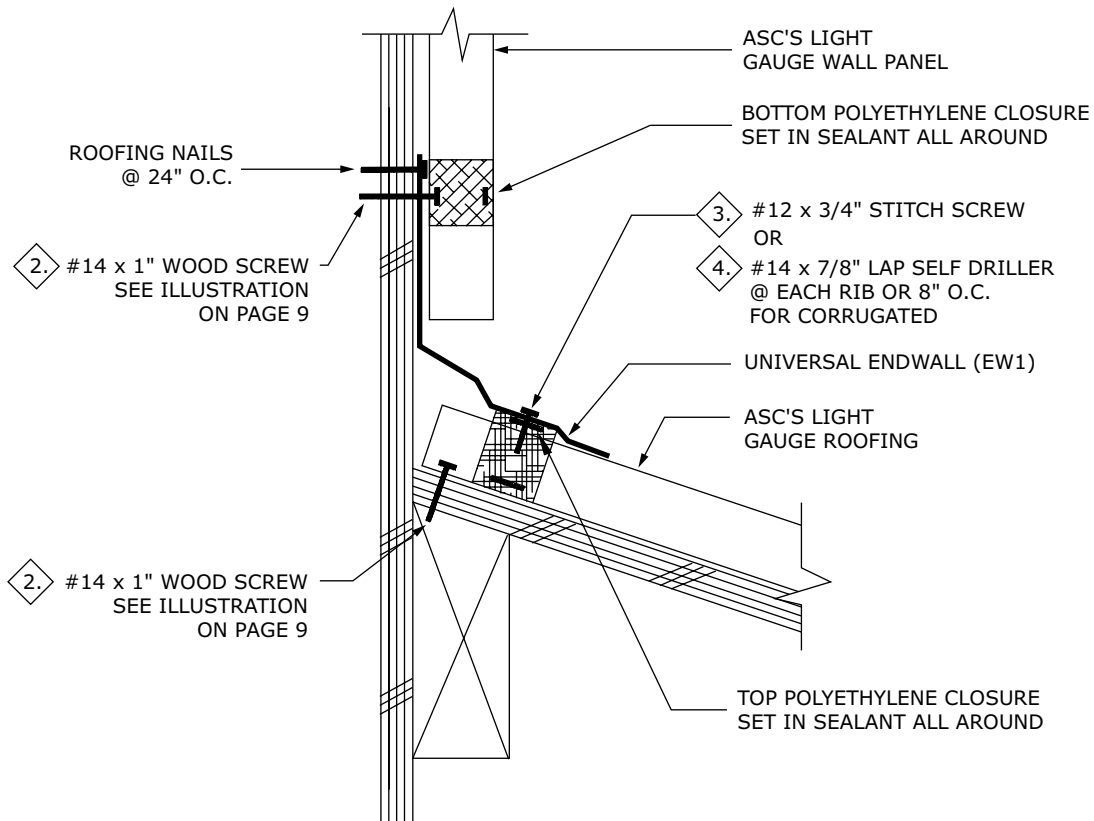
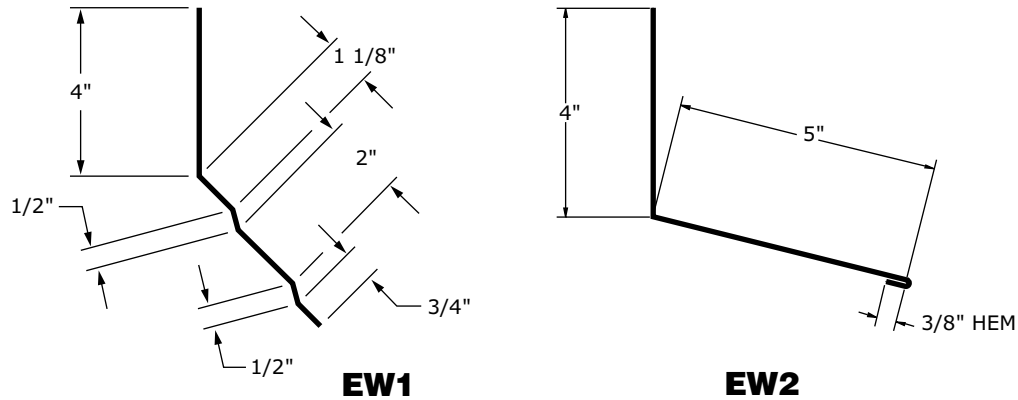

### Procedures

- Install sealant on the bottom and top of the polyethylene closure. Set the closure as shown above.
- Fasten the end wall flashing to the wall with roofing nails at 24" o.c.
- Caulk and lap the flashing a minimum of 3". (see pg. 47.)

# Light Gauge Metal Roof and Wall Panels

Installation Guide for Delta Rib, Delta Rib III, Nor-Clad®, Strata Rib® & 2½ Corrugated

## Vented End Wall Flashing

This flashing must be installed prior to wall panels.

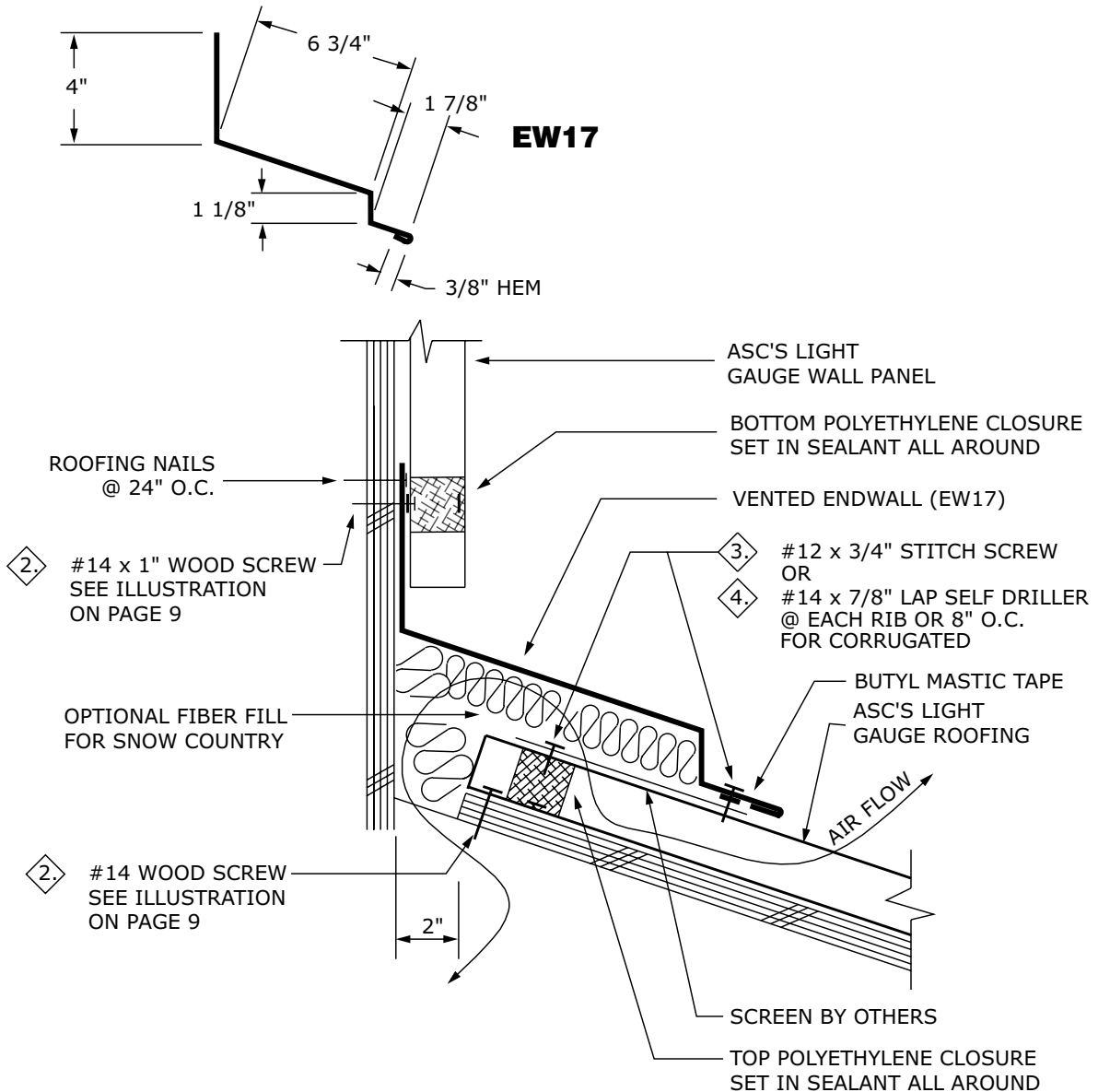

### Procedures

- Plywood should be held back 2" from the wall.
- Install sealant on the bottom and top of the polyethylene closure. Set the closure as shown above.
- Fasten the end wall flashing to the wall with roofing nails at 24" o.c. max.
- Fasten the flashing to each rib with #12 x 3/4" stitch screws. Place a small length of sealant on top of each rib as shown.
- Caulk and lap the flashing a minimum of 3". (see pg. 47)
- For Profile Vent, use (EW1) for vented endwall flashing detail.

## Slope Transition - High Slope to Low Slope

*This flashing must be installed prior to uphill panels.*

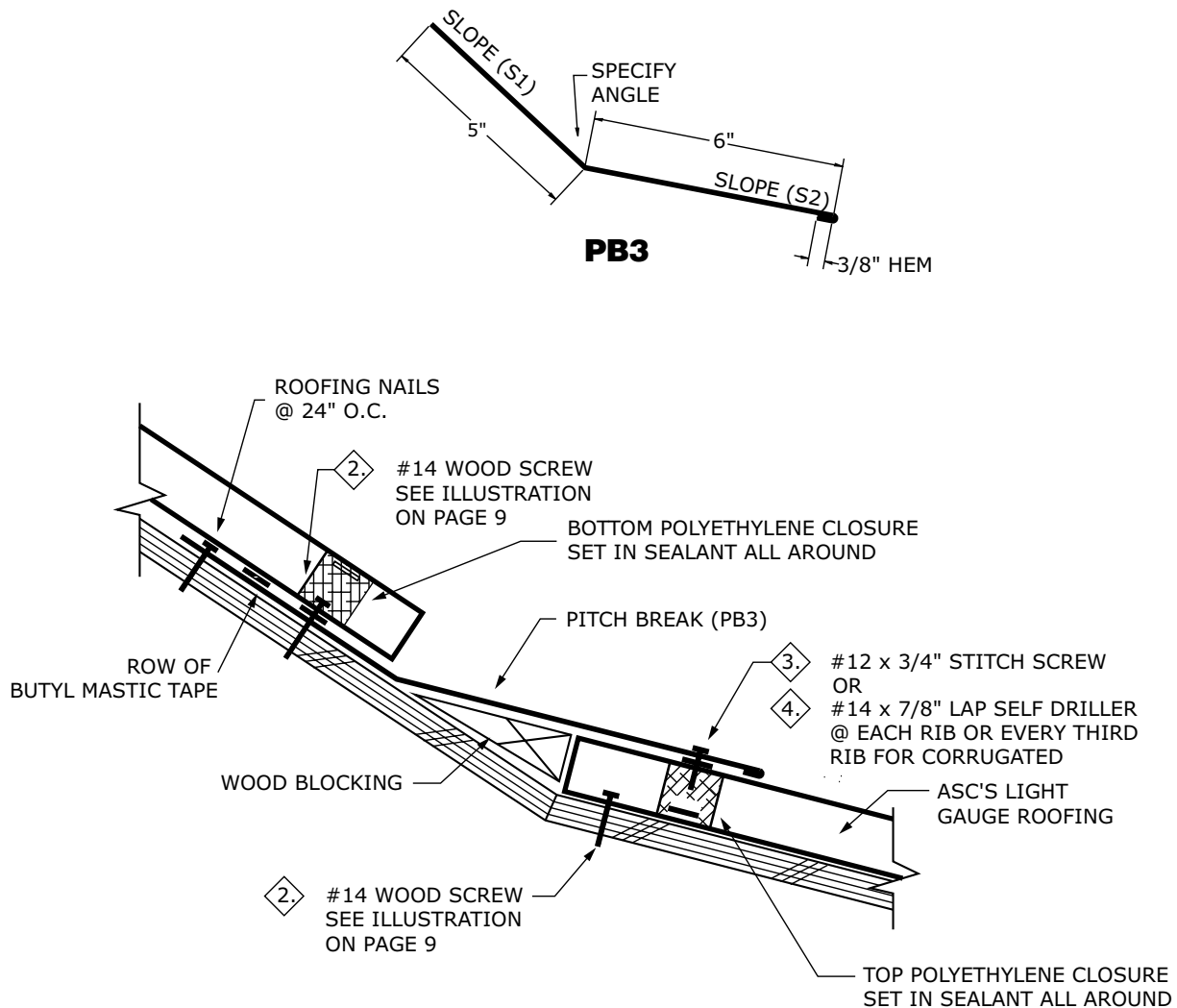

### Procedures

- Install sealant on the bottom and top of the polyethylene closure. Set the closure as shown above.
- Fasten the transition flashing to the substrate with roofing nails at 24" o.c.
- Caulk and lap the flashing a minimum of 3". (see pg. 47.)
- Parallel to the transition, place one rows of 1/2" butyl mastic tape as shown above.
- Attach the uphill panels as shown.
- Install wood blocking as needed for support.
- Place a small length of sealant on the top of each rib as shown.

## Light Gauge Metal Roof and Wall Panels

Installation Guide for Delta Rib, Delta Rib III, Nor-Clad®, Strata Rib® & 2½ Corrugated

### Slope Transition - Low Slope to High Slope

This flashing must be installed prior to uphill panels.

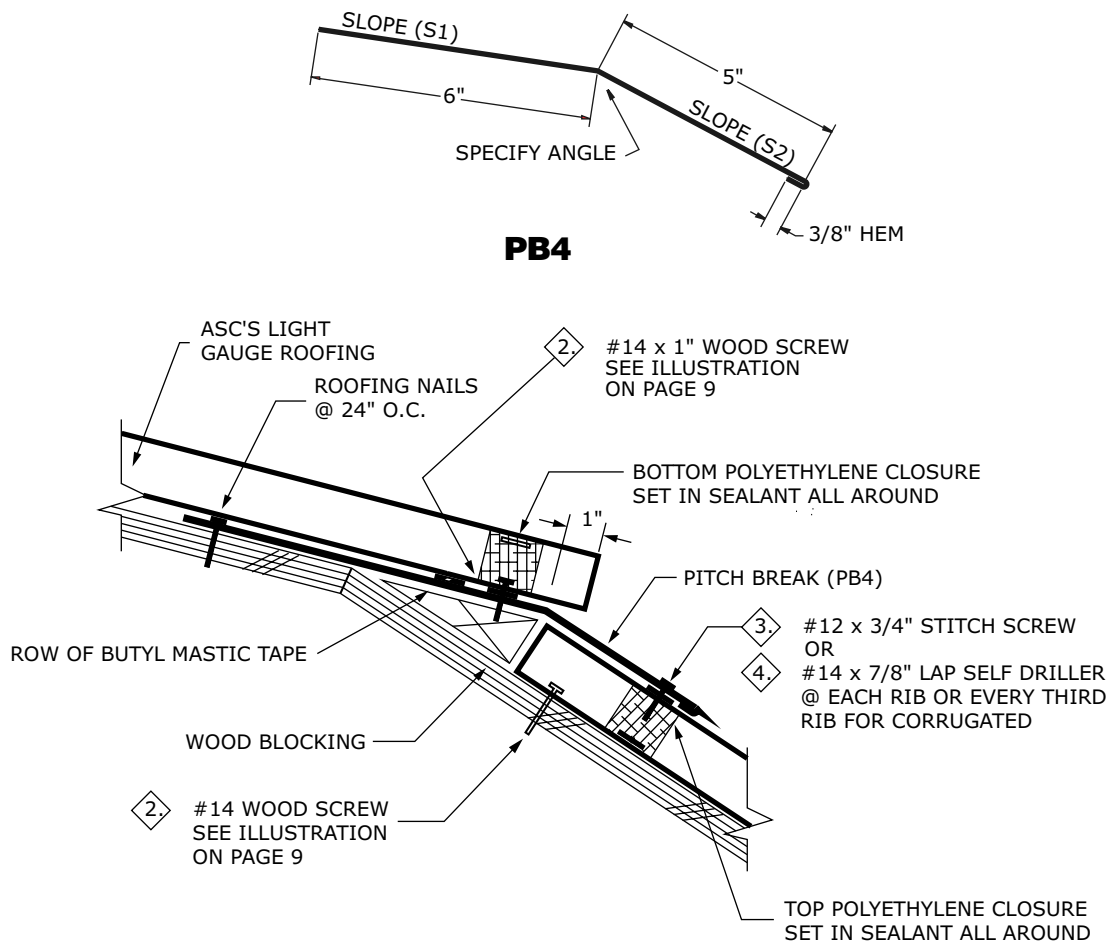

#### Procedures

- Install sealant on the bottom and top of the polyethylene closure. Set the closure as shown above.
- Fasten the transition flashing to the substrate with roofing nails at 24" o.c., prior to installing the uphill panels.
- Caulk and lap the flashing a minimum of 3". (see pg. 47)
- Parallel to the transition, place one rows of 1/2" butyl mastic tape as shown above.
- Attach the uphill panels with a 1" overhang.
- Install wood blocking as needed for support.
- Place a small length of sealant on the top of each rib as shown.

## Chalet Gable Flashing

This flashing must be installed prior to panels.

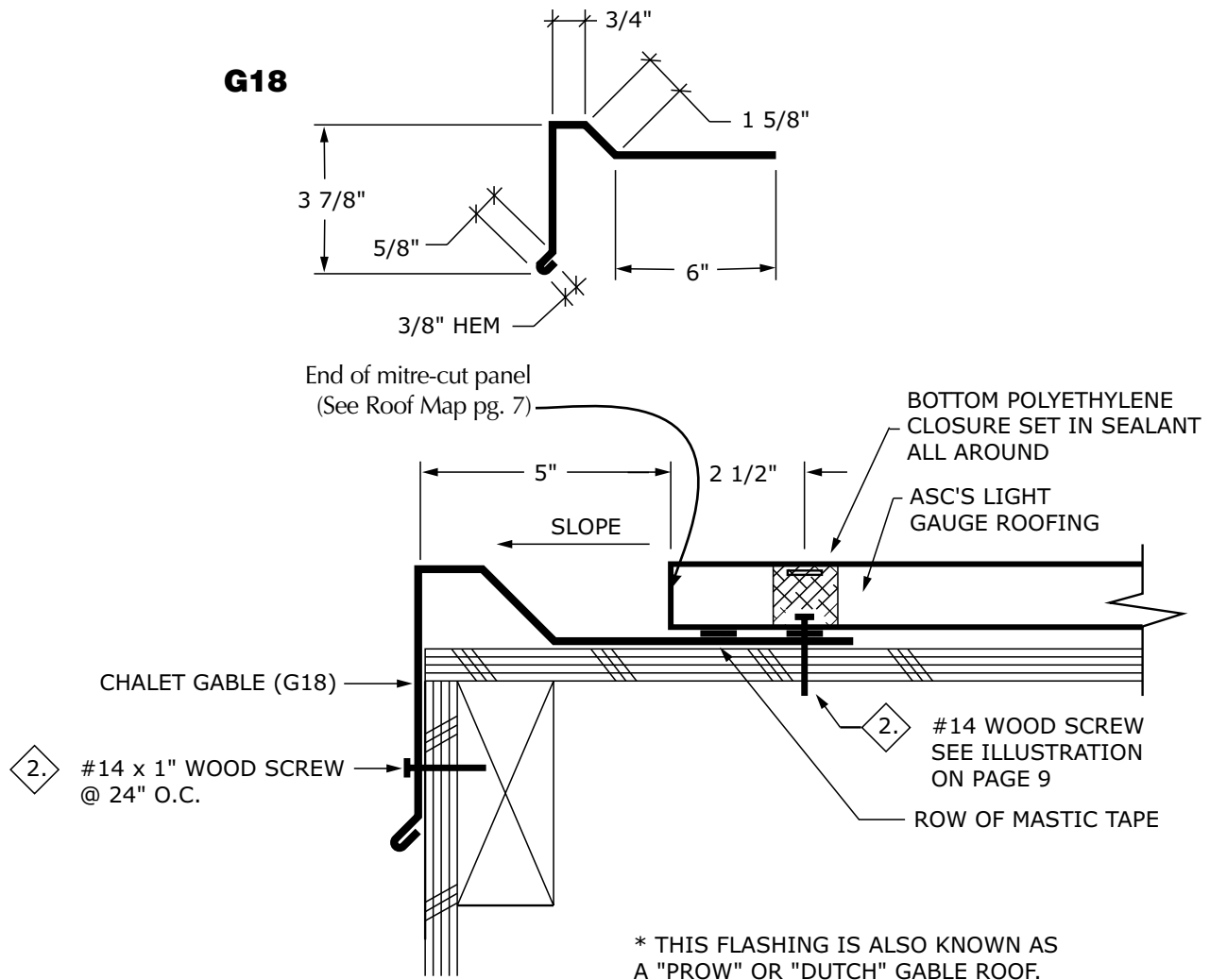

### Procedures

- Attach the chalet flashing using color matched woodscrews spaced at 24" o.c.
- Parallel to the face of the flashing, place 1/2" butyl mastic tape as shown.
- The polyethylene closures cannot be installed diagonally across a panel. At mitre cuts, use emseal closures at a right angle to the panel ribs.
- Field cut the panels holding 5" back from the face of the flashing as shown.
- Attach the panels to the roof and 'thru-fasten' along the bottom edge using #14-10 woodscrews with washer evenly spaced at 4" o.c. and at approximately 7 1/2" in from the face of the flashing so they align with the second row of tape sealant.
- Chalet gable to be used with standard eave "E1". (see pg. 18)

# Light Gauge Metal Roof and Wall Panels

Installation Guide for Delta Rib, Delta Rib III, Nor-Clad®, Strata Rib® & 2½ Corrugated

## Adjustable Gable Flashing

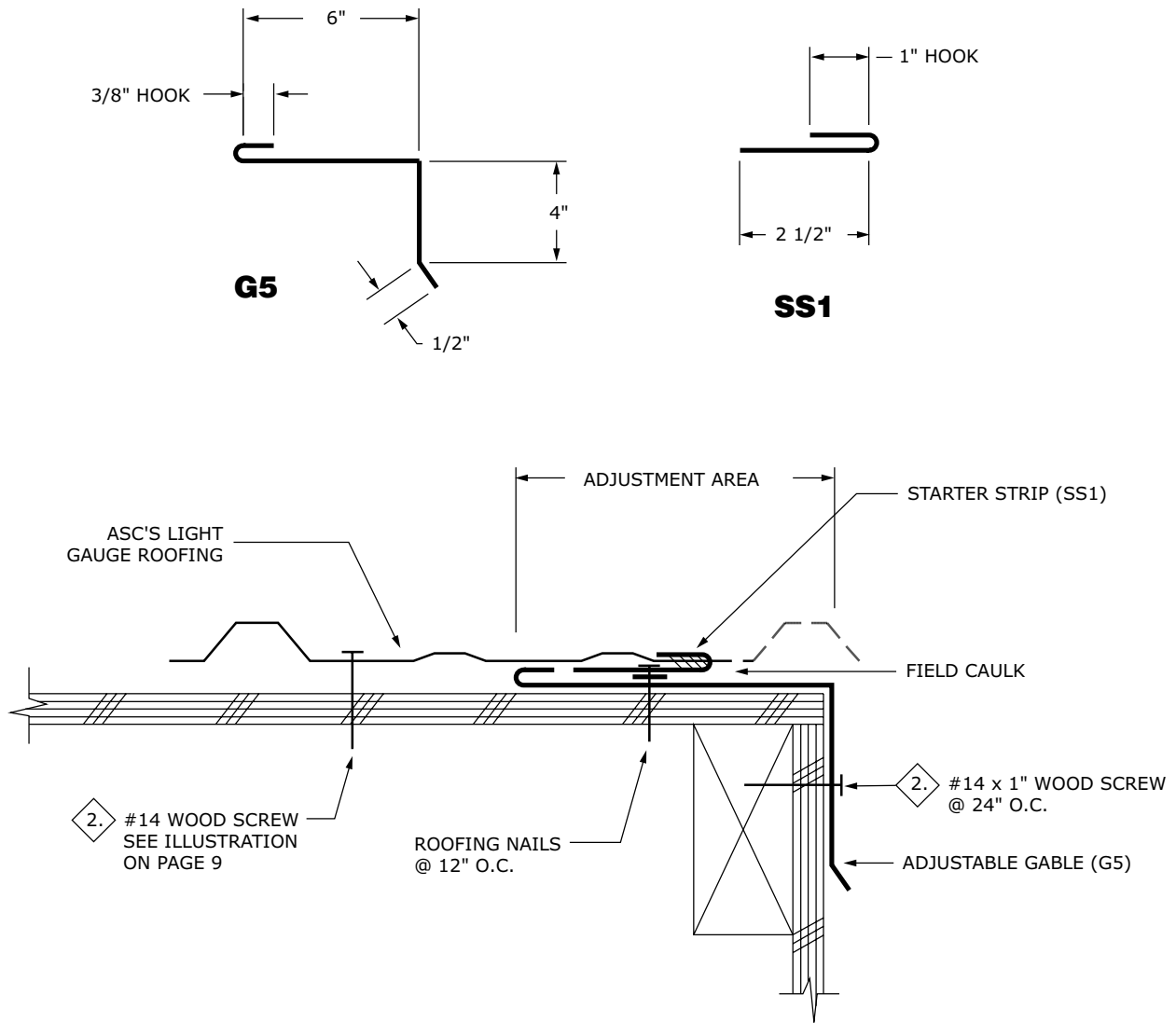

### Procedures

- In many instances, the roof sheet will have to be field modified (major rib removed along the gable). See roof map on page 7 and locate “adjustable gable”. If gable trims are used in this location, and as the roof drains from the ridge, water will flow inside the gable trims shown on page 20. The adjustable gable trim pieces shown above can assist in a proper roof installation.
- When a major rib on a Light Gauge panel occurs over the roof area within 3” of the edge of the gable, cut the panel and remove the major rib from the end of the sheet from the low eave to allow for the placement of the starter strip.
- Install the gable trim, extending the horizontal leg 6” uphill and underneath the eave on the portion of the roof sheet at the gable/eave intersection.
- Locate the placement of the starter strip to insure that the cut edge of the roof sheet can be inserted into the 1” leg of the starter strip.
- Field caulk inside the open hem and the under side of the starter strip per the detail on this page and install parallel to gable.

*Note:* Locate starter strip to allow proper installation of adjustable gable trim as shown.



## Vent Flashing

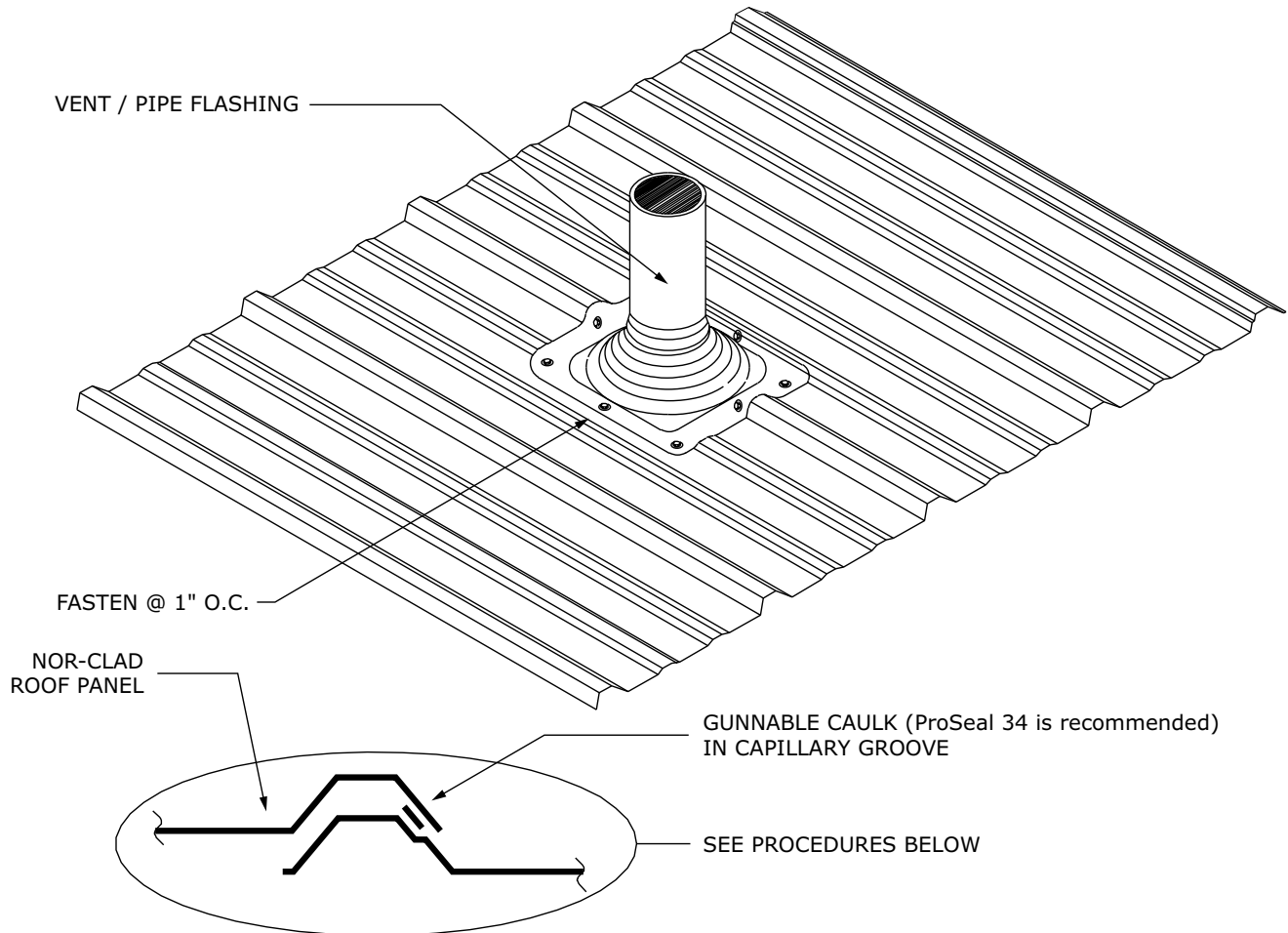

**ILLUSTRATION #5**

### Procedures

- Trim the opening in the flashing to 20% smaller than the pipe diameter.
- Slide the flashing down over the pipe.
- Seal between the vent flashing and the roofing with gunnable caulk and set the flashing.
- Form the flashing to fit the profile of the roof.
- Fasten the flashing with fasteners at 1" o.c. Refer to the fastener selection guide on page 9.
- Penetrations occurring over spaced supports require additional support framing.
- A stainless steel draw band should be installed at the top of the vent/pipe flashing.
- A minimum drainage area of 2" should be maintained between the base of the flexible vent/pipe flashing and the roof panels' major ribs.
- When a penetration occurs through a Nor-Clad® panel sidelap, gunnable caulk needs to be installed in the capillary groove from the penetration to the ridge. This will prevent water from running downhill in the capillary groove and into the roof opening. Refer to illustration #5, above.

*Note:* For the best drainage when a square-based pipe flashing is used, one corner of the flexible pipe flashing should be oriented to the high-side of the roof.

## Light Gauge Metal Roof and Wall Panels

Installation Guide for Delta Rib, Delta Rib III, Nor-Clad®, Strata Rib® & 2½ Corrugated

### Vent/Pipe Flashing Installation Procedure

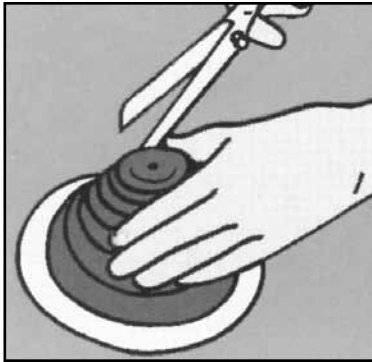

#### **STEP 1: Cut**

Cut to pipe diameter marked on Flashers (this is approximately 20% smaller than the diameter of the pipe).

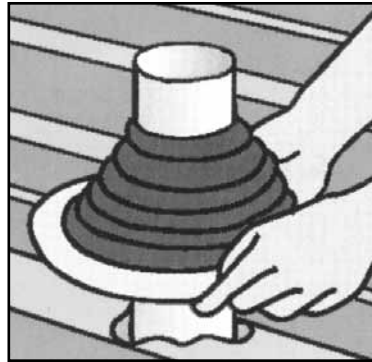

#### **STEP 2: Slide**

Slide the Flashers down the pipe, using water to lubricate if necessary.

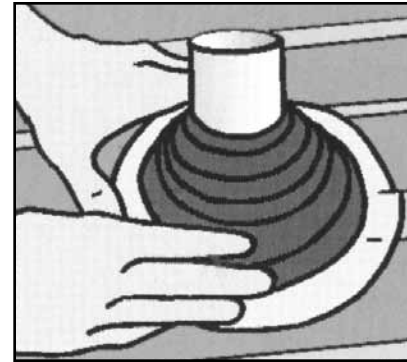

#### **STEP 3: Form**

Form and bend the aluminum base of the Flashers to fit the surface of the roof.

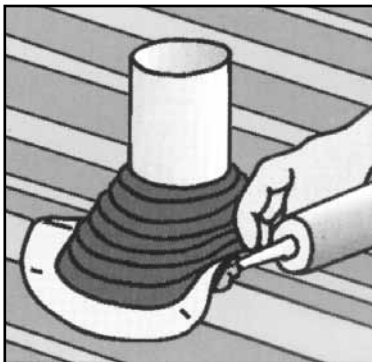

#### **STEP 4: Seal**

Seal the Flashers by applying urethane/silicone sealant between the Flasher and the roof. Use a large slot screwdriver to press the base down tightly.

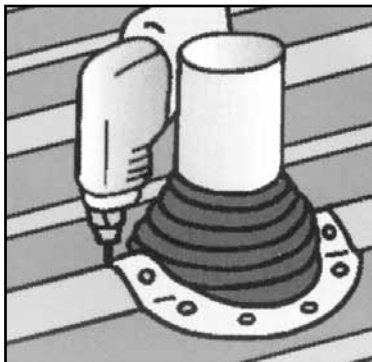

#### **STEP 5: Fasten**

Fasten the Flashers with weather-resistant fasteners to complete the seal.

*Note:* For the best drainage when a square-based pipe flashing is used, one corner of the flexible pipe flashing should be oriented to the high-side of the roof.

## Skylight Flashing

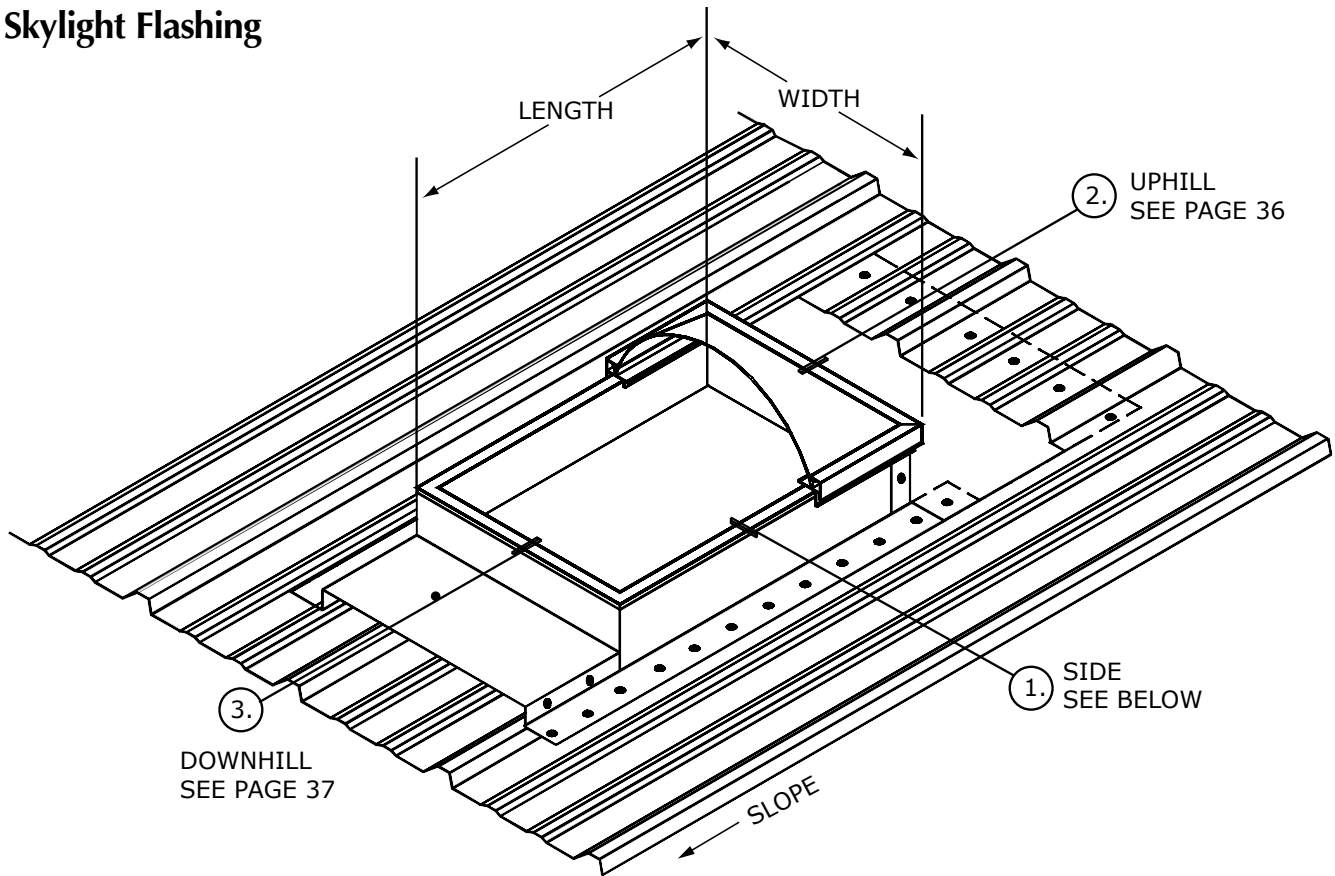

- Wherever possible, position the skylight curb so the ribs of the roof panels do not interfere with the flashing.
- Cut the light gauge roof panels as close to the left, right and downhill sides of the curb as possible. Cut the uphill side 6" up from the curb as indicated above.

- Penetrations occurring over spaced supports require additional support framing.

*Note: Do not fasten the panels within 24" uphill from the skylight until the penetration flashing is installed.*

### 1 – Skylight Flashing (Side)

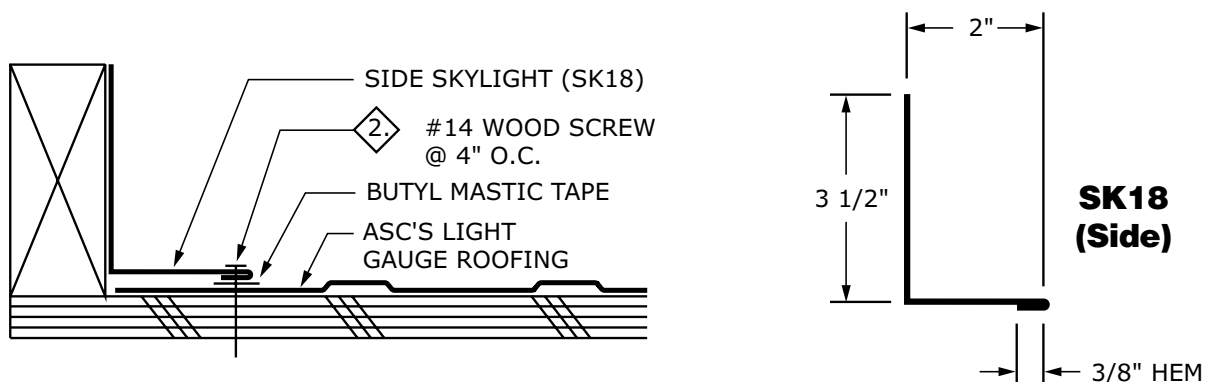

# Light Gauge Metal Roof and Wall Panels

Installation Guide for Delta Rib, Delta Rib III, Nor-Clad®, Strata Rib® & 2½ Corrugated

## 2 – Skylight Flashing (Uphill Side)

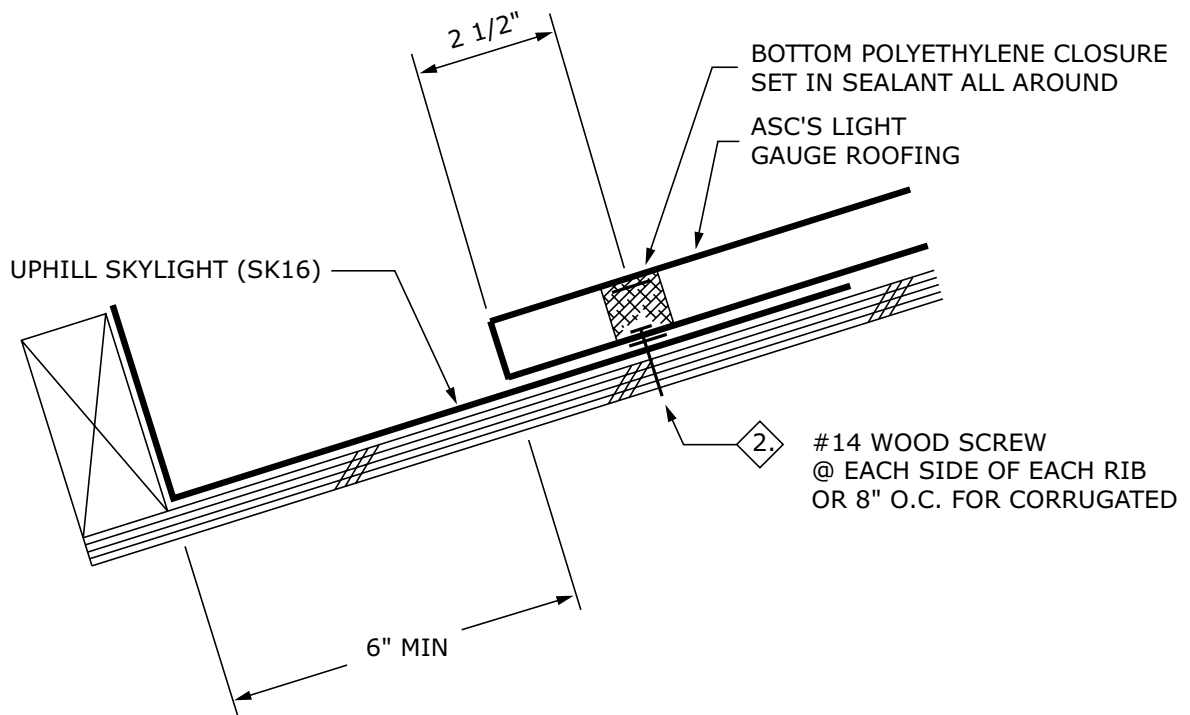
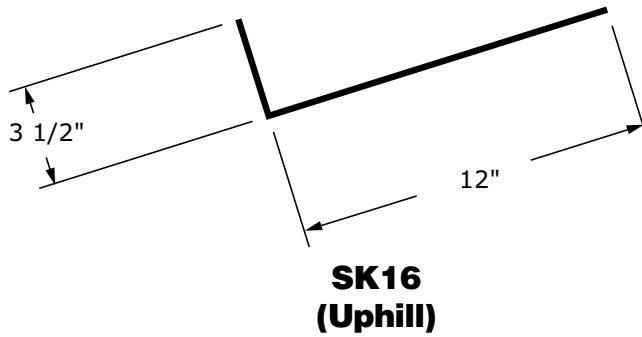

③ – Skylight Flashing (Downhill Side)

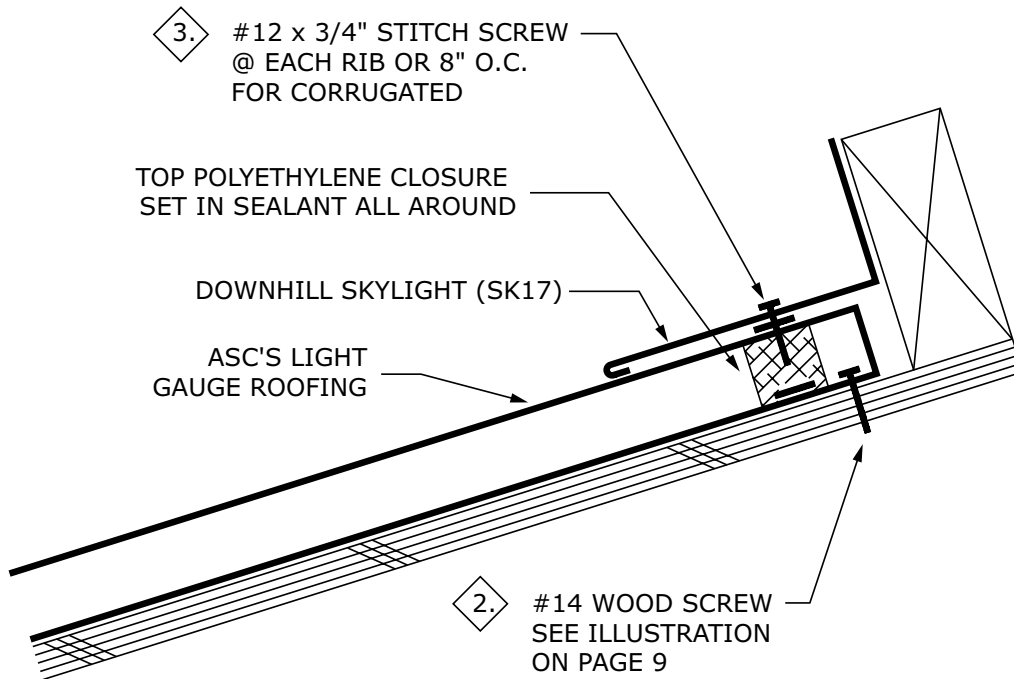
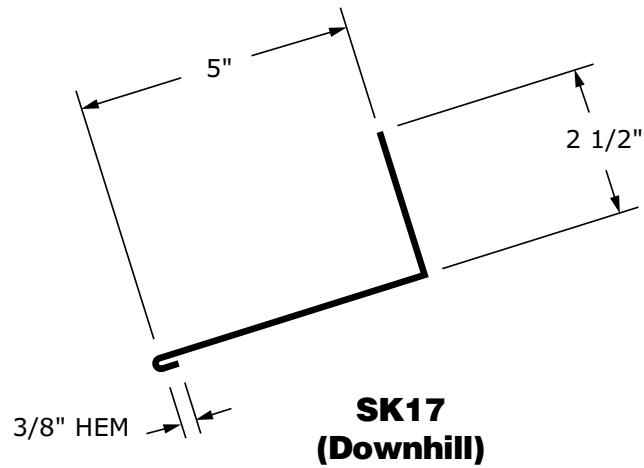

## Procedure for the Installation of Skylight Flashings

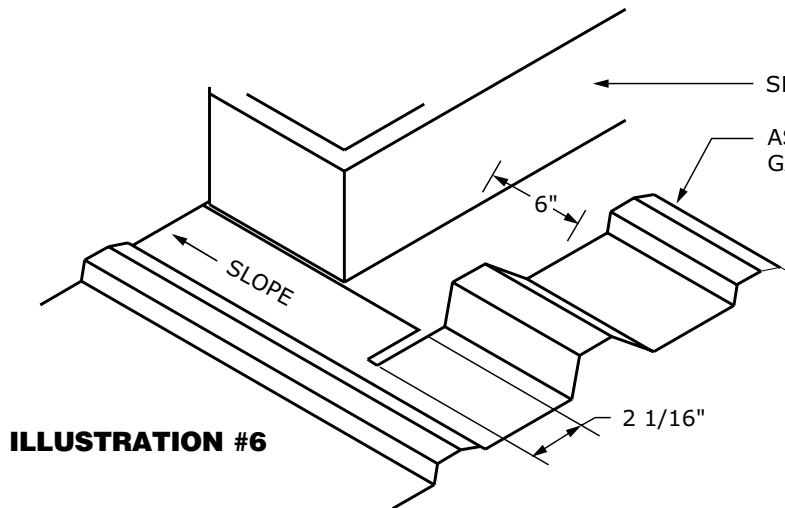

**ILLUSTRATION #6**

The skylight flashing will be 4" wider than the width of the curb (2" on each side). Cut a 1/8" slot in the two uphill corners of the Light Gauge Roofing Panel slightly wider than 2", so the uphill flashing can slide through the two slots.

(See illustration #6).

Adjustments to the horizontal leg dimension and length of slit may have to be modified depending on the location of the panels' major rib.

## Skylight Flashing Preparation

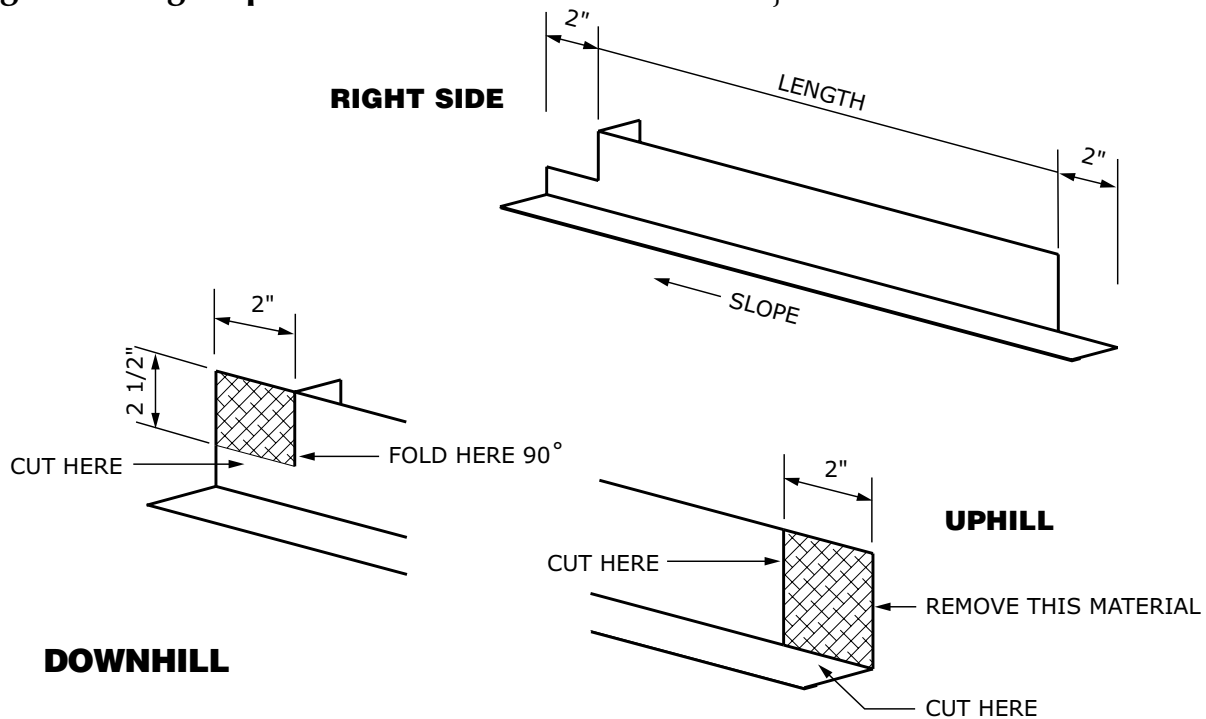

Trim and bend the right side skylight flashing as indicated. Trim the left side in a similar fashion.

## Skylight Flashing Preparation (continued)

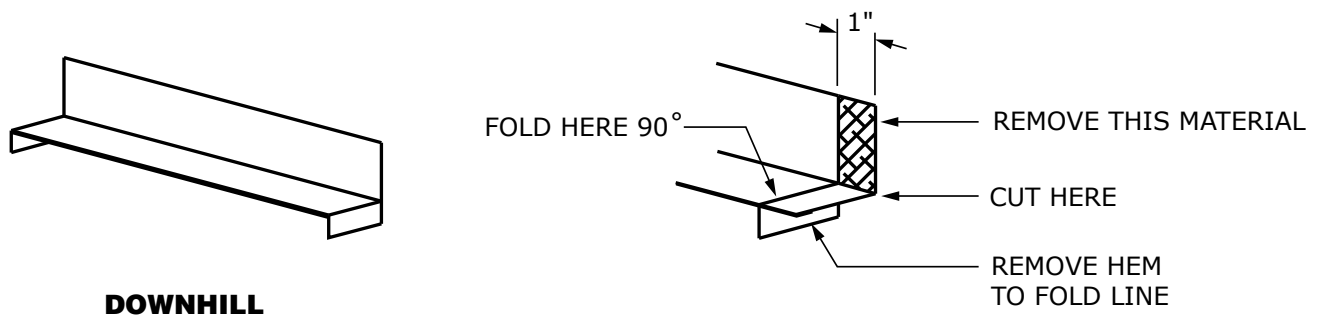
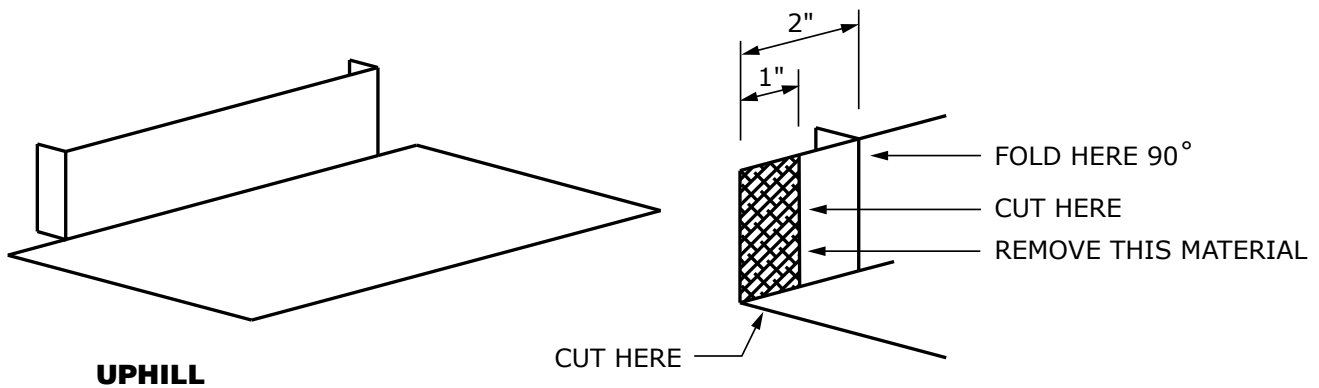

- Trim both ends of the uphill and downhill sides of the skylight flashing as indicated.
- Slide the uphill flashing into the slots of the Light Gauge Roofing and apply liberal amount of gunnable caulking.
- Assemble the skylight as indicated on *pages 35-39*.
- Trim and assemble chimney flashing similarly.

# Light Gauge Metal Roof and Wall Panels

Installation Guide for Delta Rib, Delta Rib III, Nor-Clad®, Strata Rib® & 2½ Corrugated

## Chimney Flashing

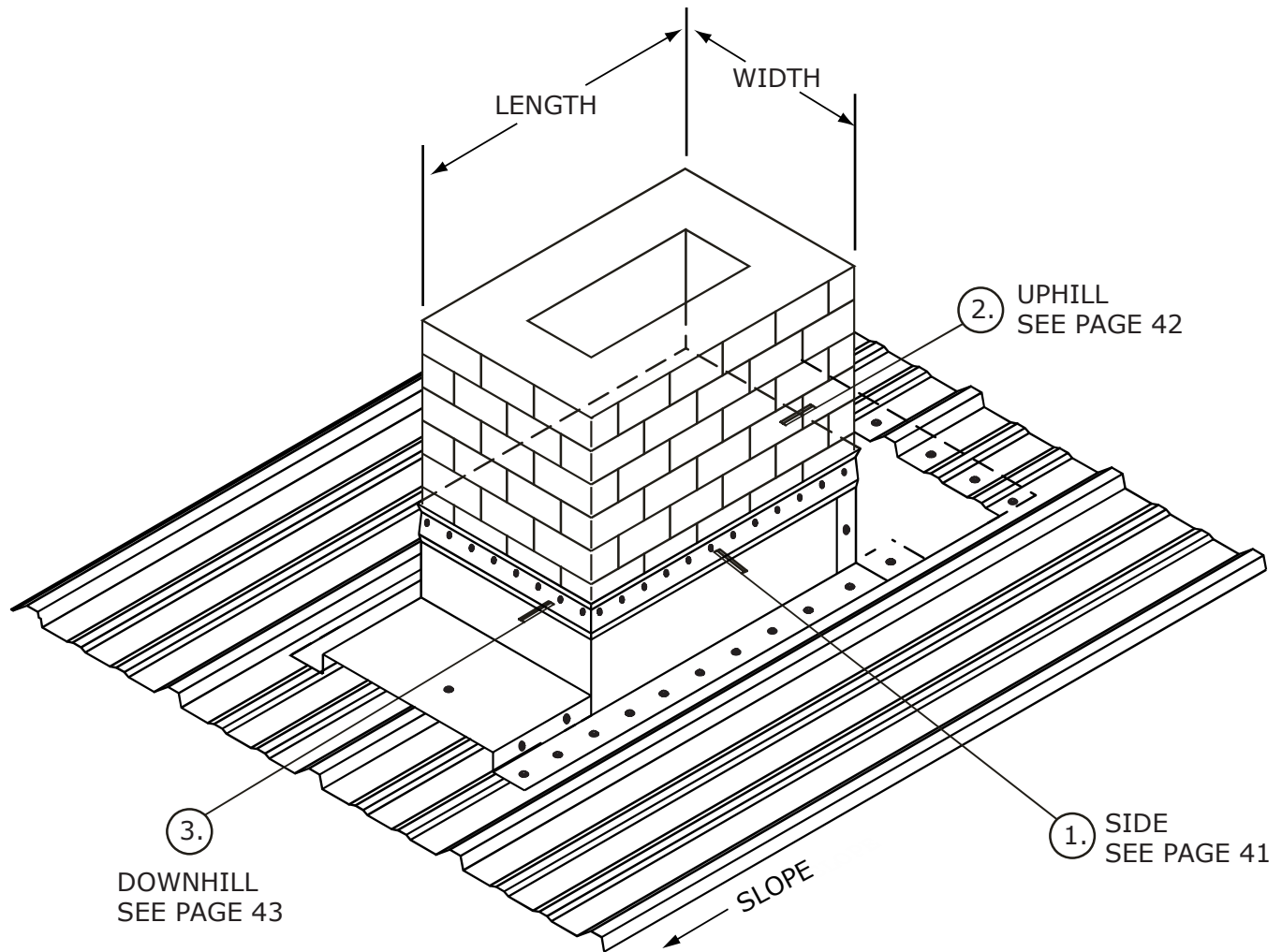

*Note:* Procedures for the installation of chimney flashings are similar to the skylights. (see pgs. 35-39). The reglet\*\* shown may be deleted if the chimney is clad with siding. (Lap the siding over the flashing and caulk). Be sure to specify the slope and the orientation of the chimney dimensions when ordering this assembly.

\*\* A reglet is a two-piece flashing found on the side of a wall, chimney or other similar roof penetration. (see flashing drawing pg. 43).



① – Chimney Flashing (Side)

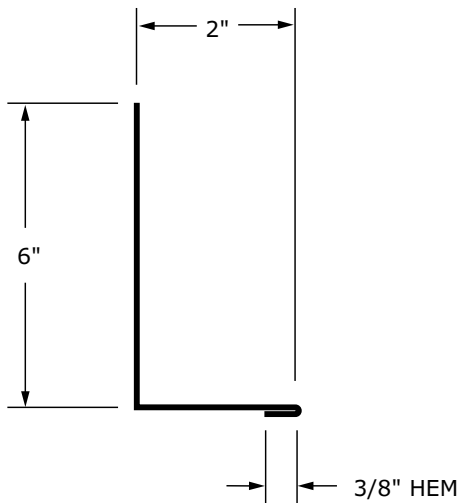

**CH18  
(Side)**

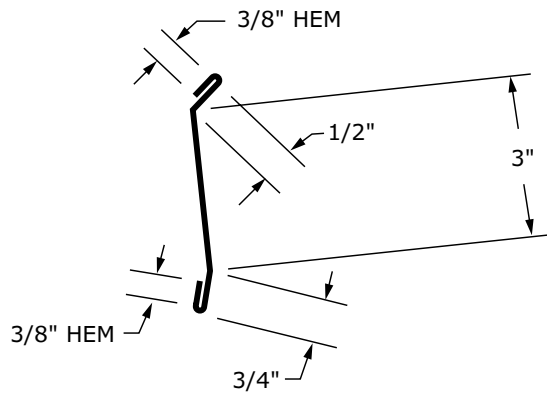

**RG16  
(Reglet)**

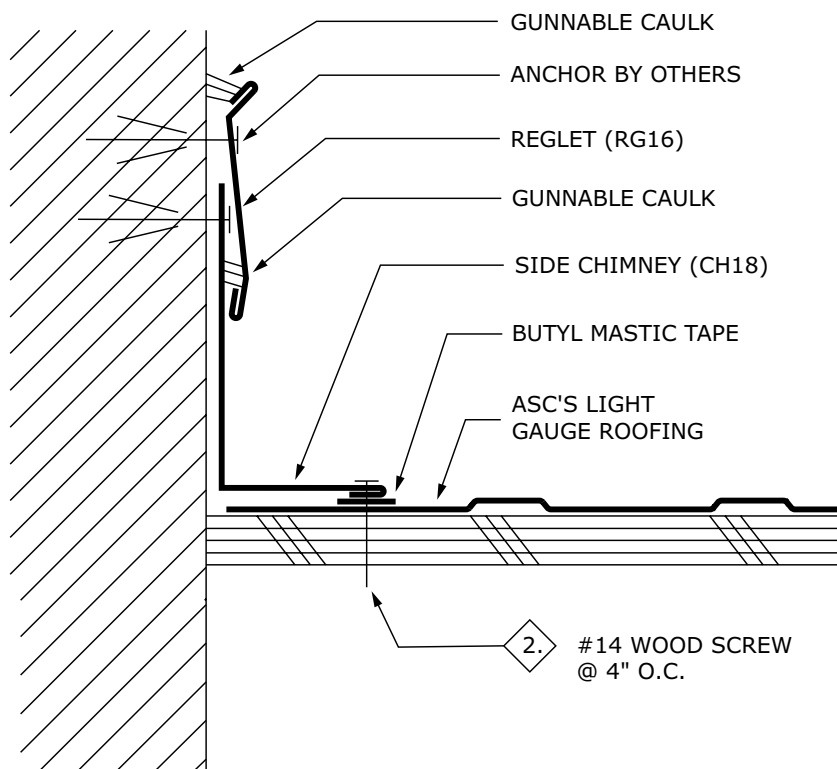

# Light Gauge Metal Roof and Wall Panels

Installation Guide for Delta Rib, Delta Rib III, Nor-Clad®, Strata Rib® & 2½ Corrugated

## 2 – Chimney Flashing (Uphill)

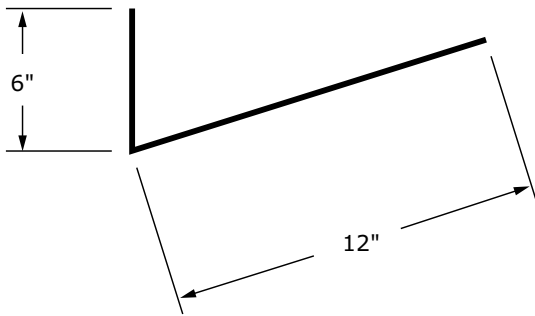

**CH16  
(Side)**

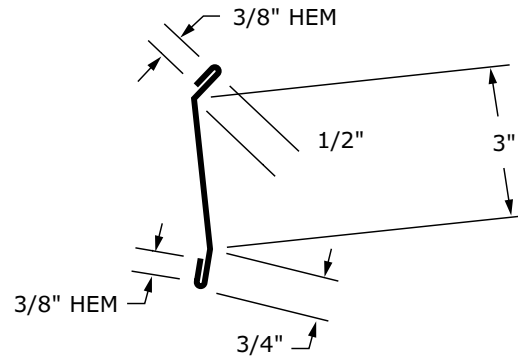

**RG16  
(Reglet)**

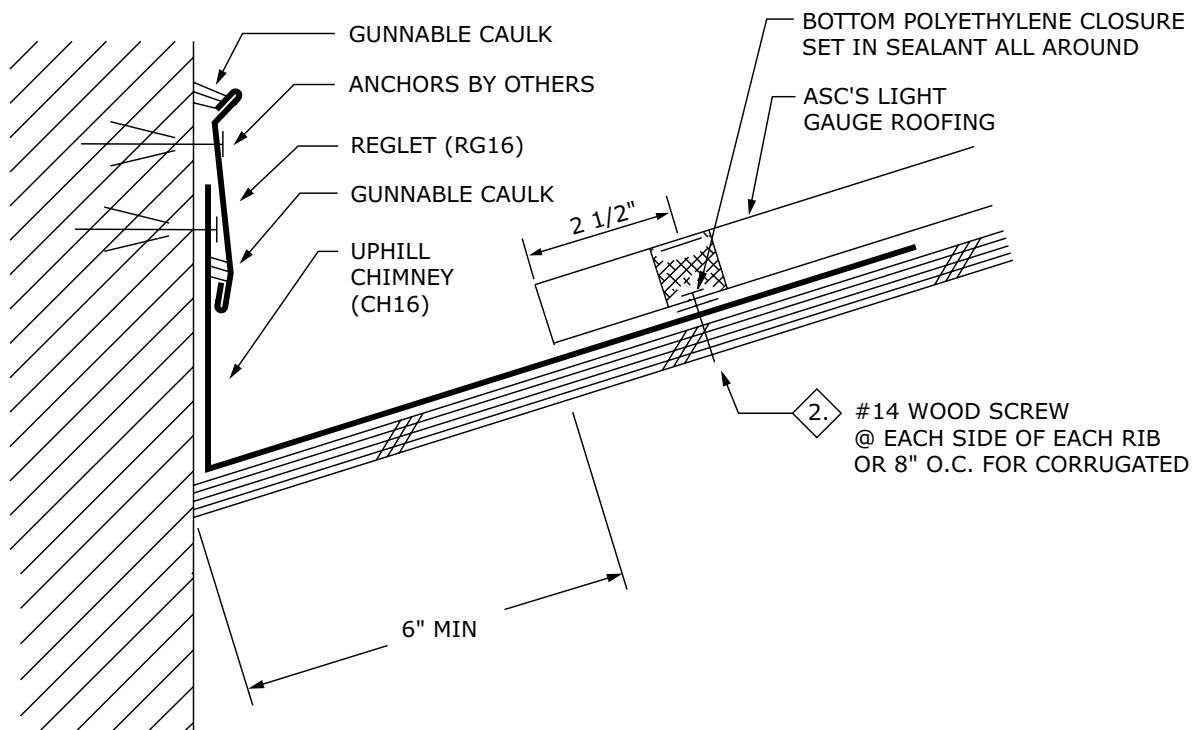

**3** – Chimney Flashing (Downhill)

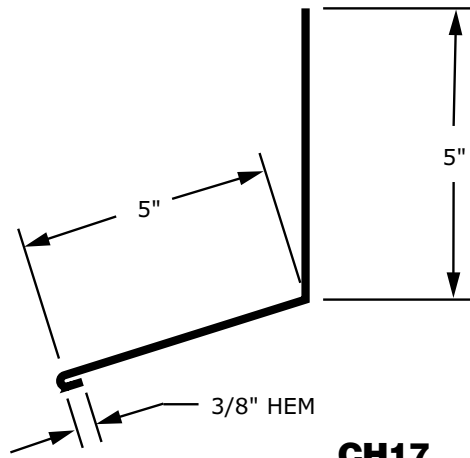

**CH17  
(Downhill)**

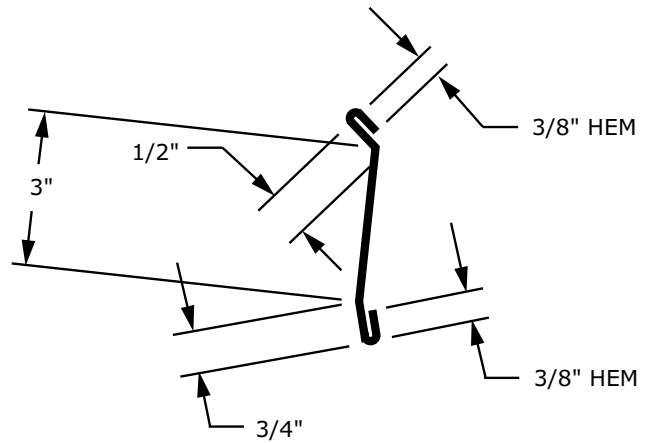

**RG16  
(Reglet)**

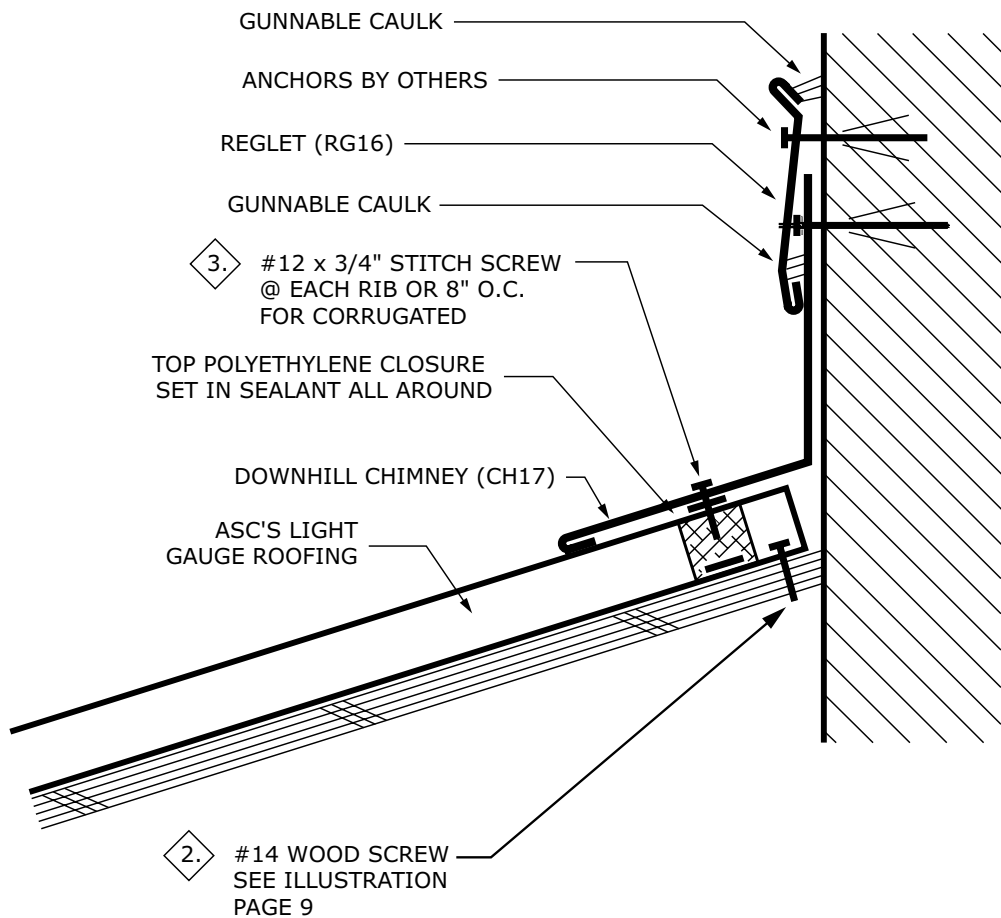

# Light Gauge Metal Roof and Wall Panels

Installation Guide for Delta Rib, Delta Rib III, Nor-Clad®, Strata Rib® & 2½ Corrugated



## Valley Top End

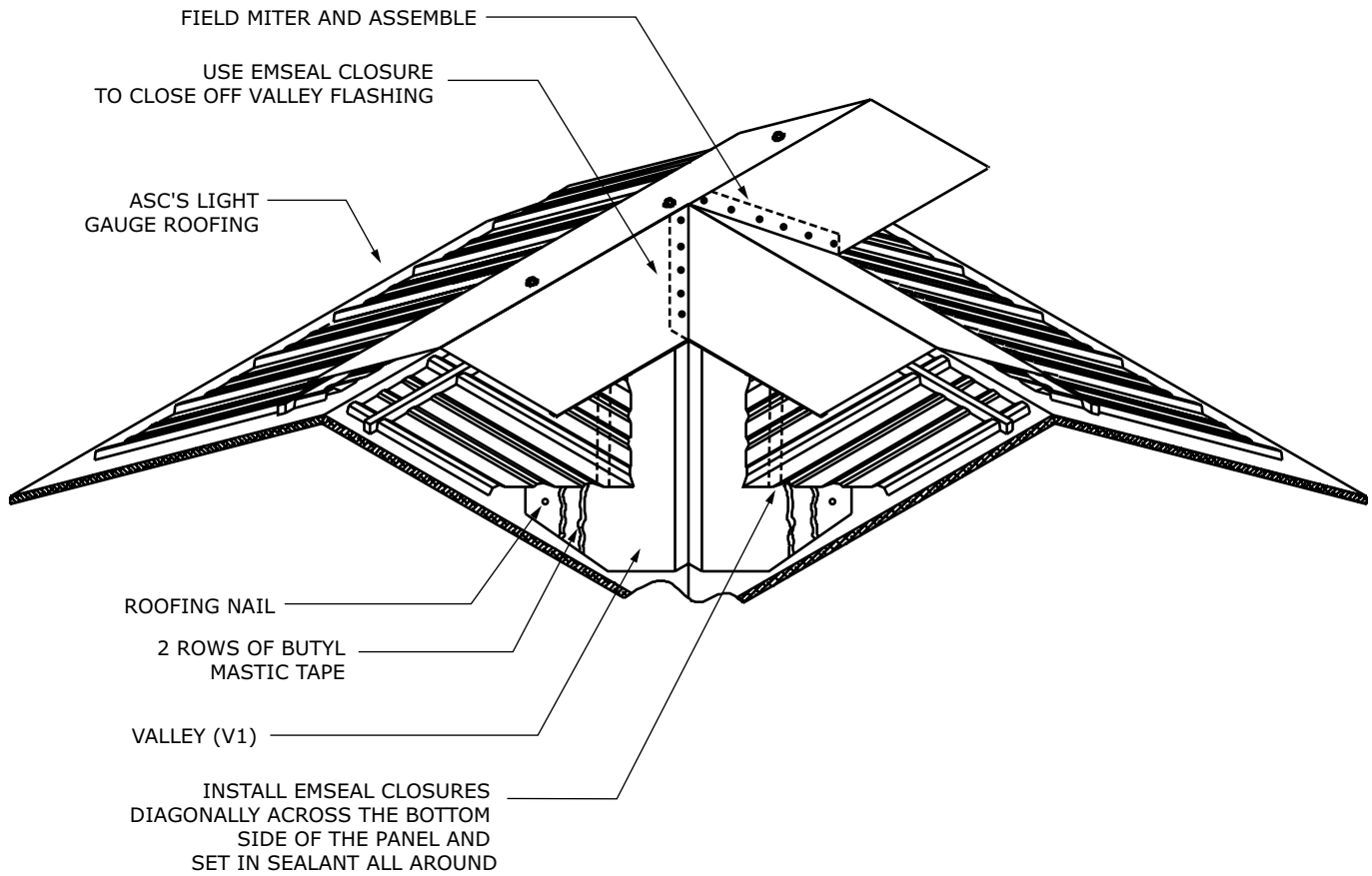

## Valley Dormer

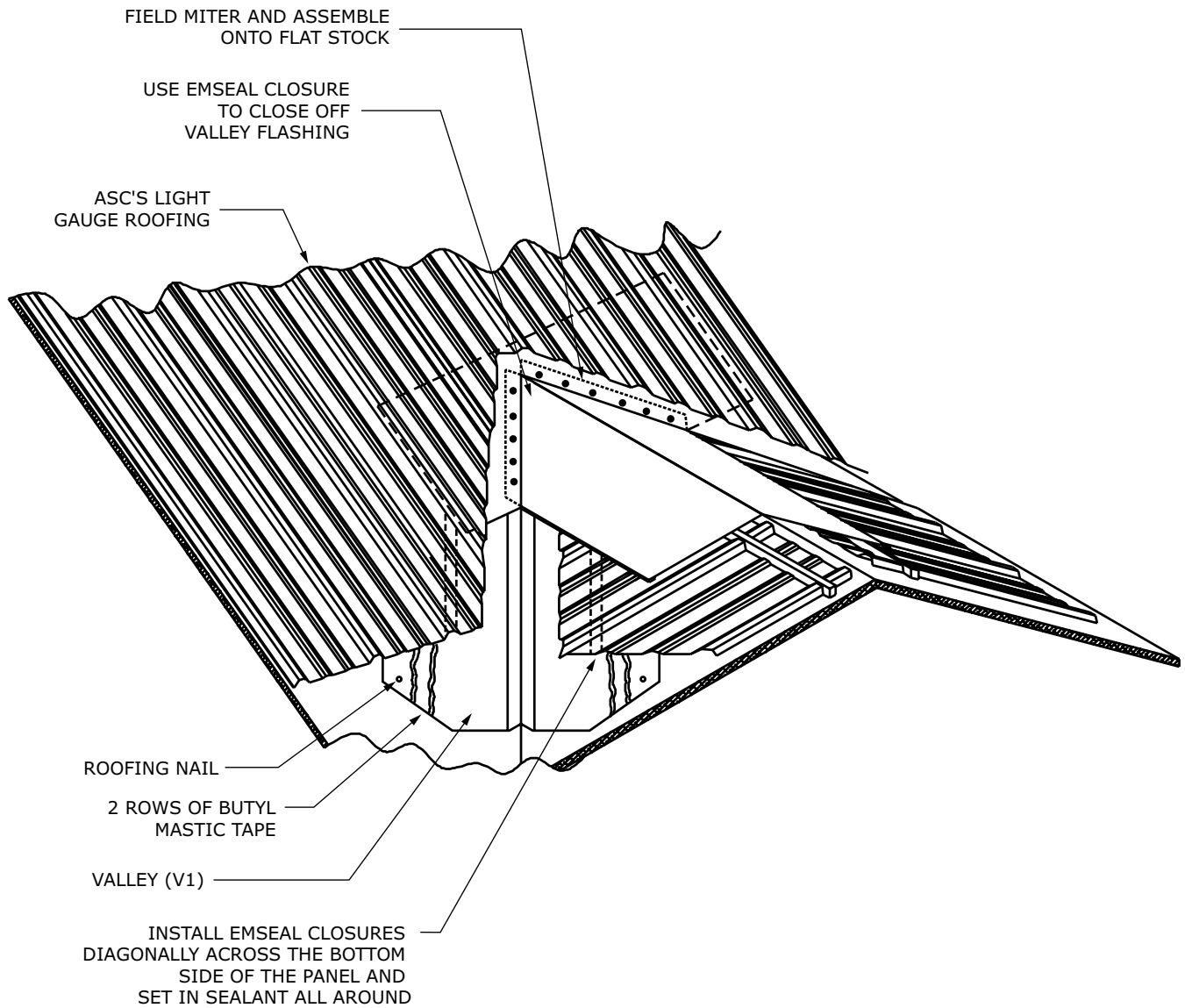

# Light Gauge Metal Roof and Wall Panels

Installation Guide for Delta Rib, Delta Rib III, Nor-Clad®, Strata Rib® & 2½ Corrugated



## Panel End Lap

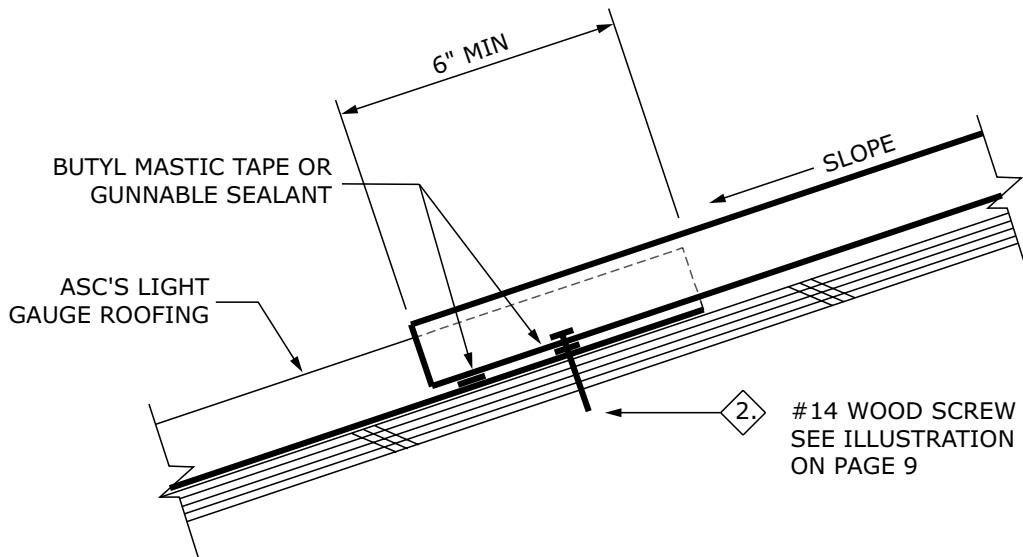

## Long Panel End Lap

For panels 28 ft. or longer

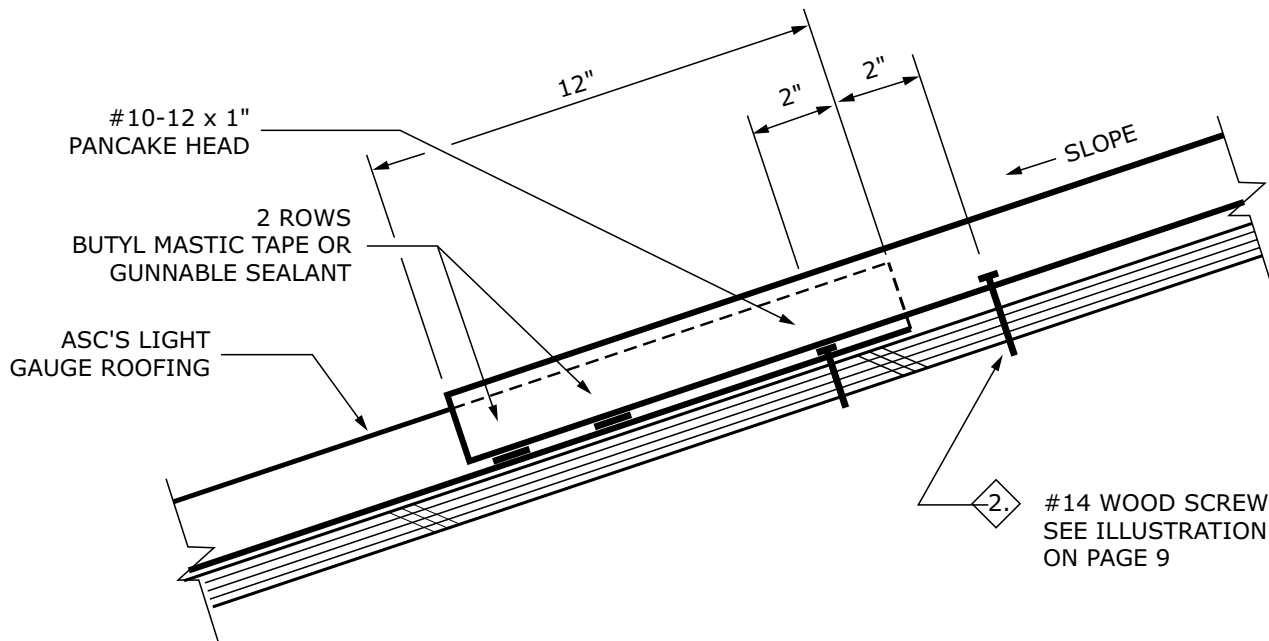

Note: Use this detail so that panels can expand and contract independently.

## Sealing End Laps & Lapping the Hems

### Typical Flashing Lap

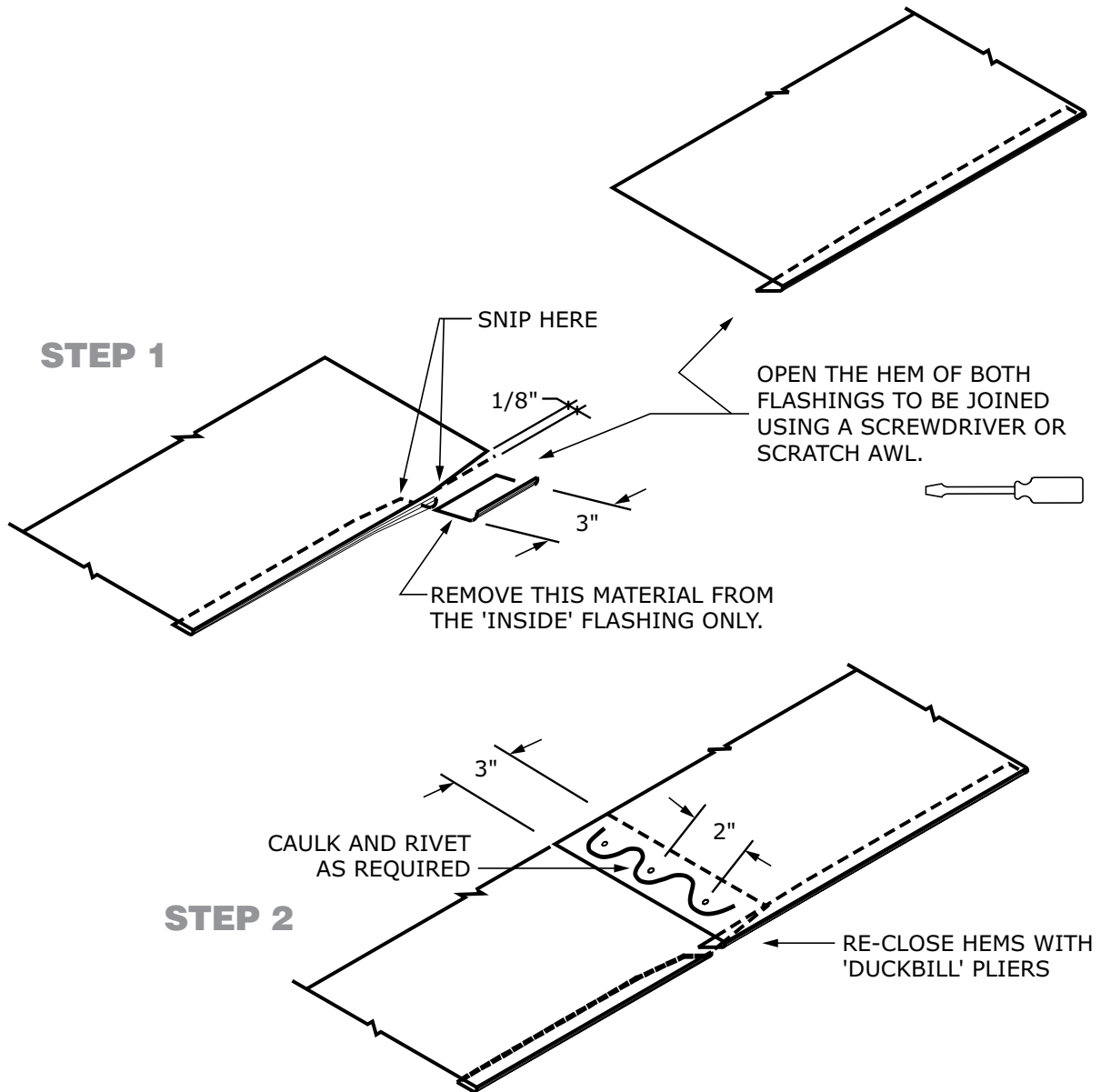

Note: Flashing expansion joints may be required for long flashing runs (i.e. 40 ft. ±).

# Light Gauge Metal Roof and Wall Panels

Installation Guide for Delta Rib, Delta Rib III, Nor-Clad®, Strata Rib® & 2½ Corrugated

## Wall Details

### Window/Door Trim Corner

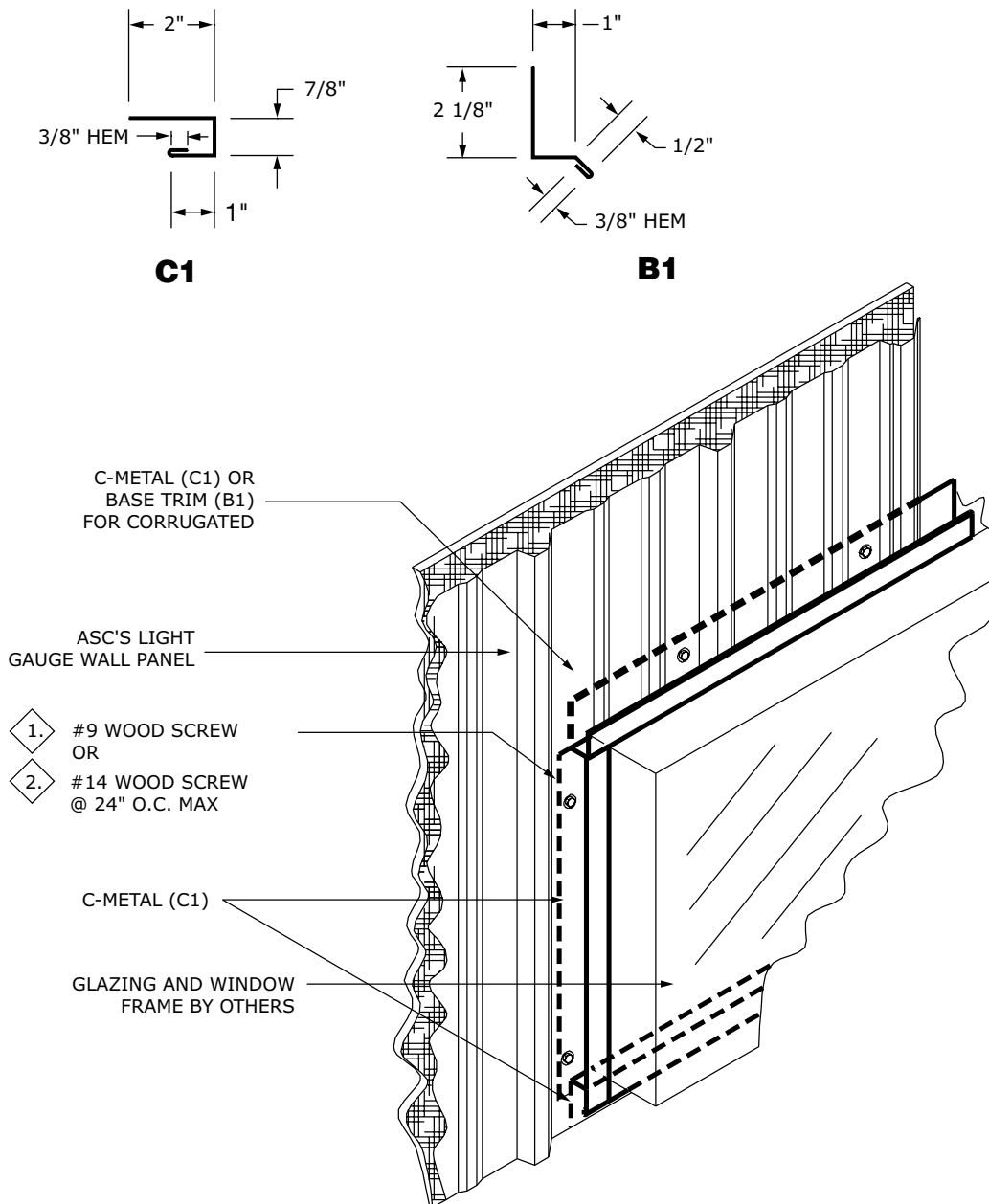

### Procedures

- When installing Light Gauge panels, "B1", the Drip Flashing, is preferred at the head.
- A horizontal cut, 1" long, needs to be made in the wall panel at the intersection of the jamb and head trim. Extend the head trim into this slot, allowing for proper drainage to the outside of the building.
- Concealed neoprene closures left out for clarity. Place inside closure behind panel at C-metal (C-1) or base trim (B1)

*Note: "C1" is shown at head location. "B1", Base Trim, can also be used.*



## Wall Details Top and Bottom Trim

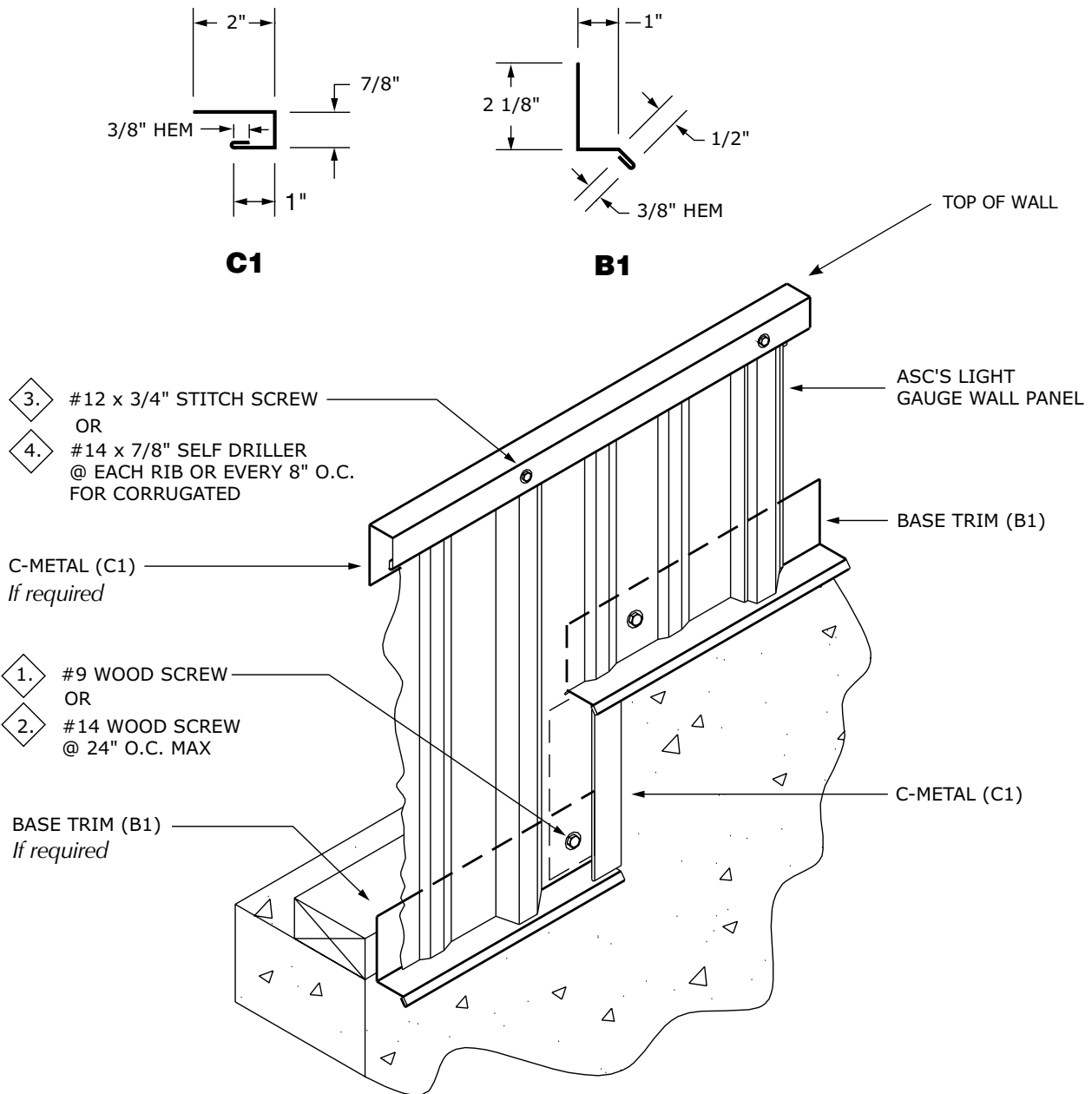

### Procedures

- Open framing shown. If installing over plywood, use a #14 x 1" woodscrew for panel attachment.
- Concealed neoprene closures left out for clarity. Place bottom closure behind panel at base trim and top closure on top of sheet behind "C1" at panel top, if required.

# Light Gauge Metal Roof and Wall Panels

Installation Guide for Delta Rib, Delta Rib III, Nor-Clad®, Strata Rib® & 2½ Corrugated

## Wall Details Inside Corner

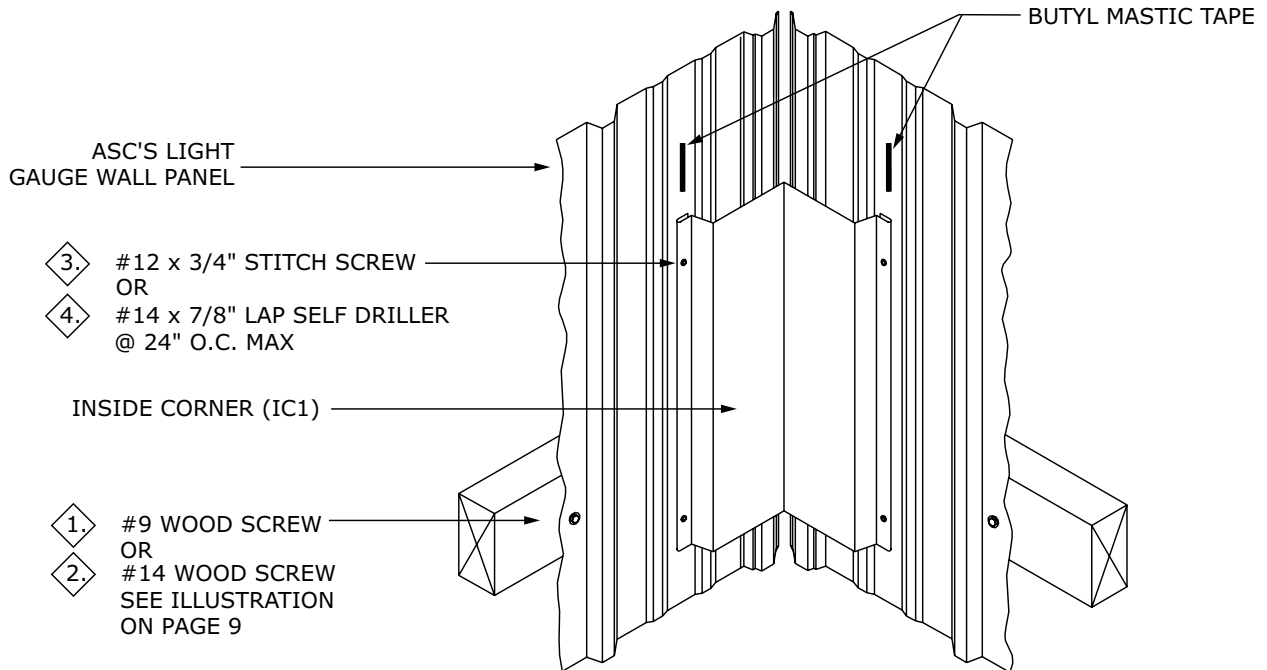
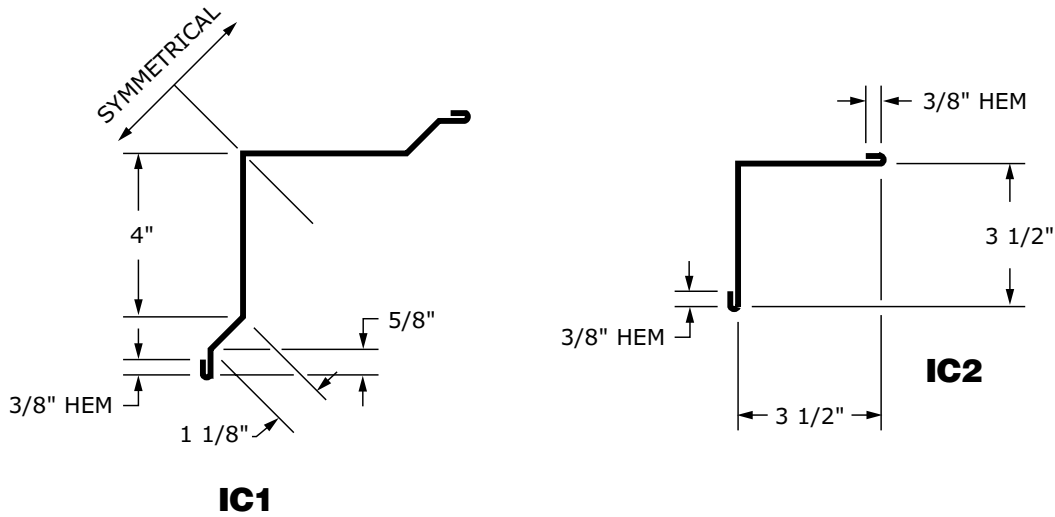

### Procedures

- Open framing shown. If installing over plywood, use a #14 x 1" woodscrew for panel attachment.
- Nor-Clad® or Super-Span® panel shown. When installing other Light Gauge panels, use the Universal Inside Corner "IC2".
- In many situations, the last panel installed at the corner will require that the panel be cut in width. Allow the cut edge to be covered by the inside corner trim.

## Wall Details Outside Corner

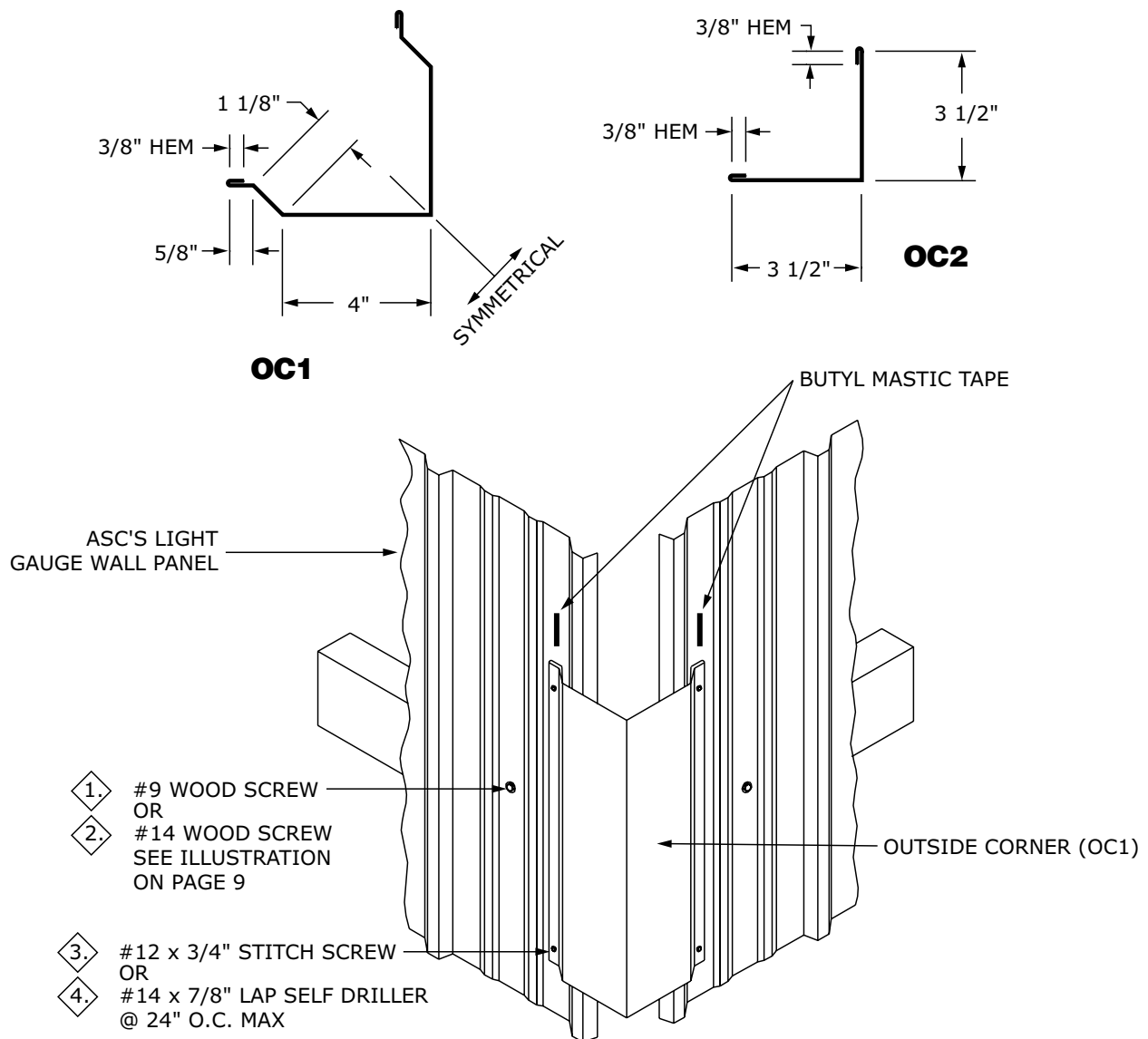

### Procedures

- Open framing shown. If installing over plywood, use a #14 x 1" woodscrew for panel attachment.
- Nor-Clad® panel shown. When installing other Light Gauge panels, use the Universal Outside Corner "OC2".
- In many situations, the last panel on each side will project beyond the building corner, requiring the panel to be cut in width. Allow the cut edge to be covered by the outside corner trim.