









PREPARING FOR NAIL FIN WINDOW INSTALLATION











YOU WILL NEED TO SUPPLY:

- Moisture resistant shims/spacers 
- Fasteners (see nail fin anchor instructions and tables at the end of this booklet) 
- Closed cell foam backer rod/sealant backer 
- Pella® SmartFlash™ foil backed butyl window and door flashing tape or equivalent 
- Low expansion, low pressure polyurethane insulating window and door foam sealant DO NOT use high pressure or latex foams. 
- Pella Window and Door Installation Sealant or equivalent high quality, multi-purpose sealant 

Other construction materials may be required.

Read and understand the instructions and inspect the wall conditions before you begin.

TOOLS REQUIRED:

- Tape measure 
- Level 
- Square 
- Hammer 
- Stapler 
- Scissors or utility knife 
- Small flat blade screwdriver 
- Sealant Gun 
- Screw Gun with a Phillips Driver bit 
- 1/8" Allen wrench 

INSTALLATION WILL REQUIRE (2) OR MORE PERSONS FOR SAFETY REASONS.

Store windows in upright position, out of direct sunlight.

ROUGH OPENING VERIFICATION

- Confirm the opening is plumb and level.

NOTE: It is critical the bottom is level and it does not slope to the interior.

- Remove dirt, oil or debris from the opening and surrounding wall surfaces.

- Confirm the window will fit the opening. Measure all four sides of the opening to make sure it is 1/2" to 3/4" larger than the window in both width and height. On larger openings measure the width and height in several places to ensure the header or studs are not bowed.

NOTE: 1-1/2" or more of solid wood blocking is required around the perimeter of the opening.

Fix any problems with the rough opening before proceeding.

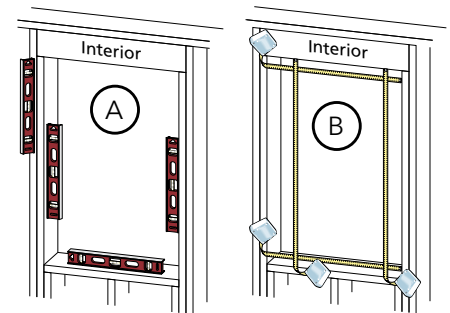

PREPARE THE WINDOW FOR INSTALLATION

- Remove plastic wrap and cardboard packaging from window. DO NOT cut checkrail bands (if present) or remove plastic or foam shipping spacers located between the window sash and frame. DO NOT open the window until it is securely fastened.

- Inspect the product for any damage such as cracks, dents or scratches. DO NOT install damaged windows.

- Remove screens and hardware (if necessary). Label them and set them aside in a protected area.

Windows with Half Screens: From the exterior, pull one side of the screen near the shipping clips until the clips disengage from the frame. Rotate the shipping clips toward the exterior of the screen until they snap free from the screen.

Half screens of some vinyl windows can be removed from the interior.

- Fold out installation fin to 90° (units with fold up fin only).

Be careful not to remove or tear the fin corners.

NOTE: If the fin is not at 90°, the window will not line up correctly on the interior.

- Curved Units with Fins:** Install clips on wood windows with non-structural flex fins or pre-drill holes on wood windows with rigid curved fin. See nail fin anchor instructions at the end of this booklet.

Curved Units with Flexible Fins: Install Clips or pre-drill holes for frame screws Curved units with Rigid Fins: pre-drill holes through fin.

Units with wide EnduraClad Exterior trim and narrow fins with NO pre-punched holes: Install clips or pre-drill holes for frame screws.

See nail fin anchor instruction at the end of this booklet.

Additional preparation may be required for performance upgrade, impact resistant products or to comply with local building code requirements.

- Read the entire instruction before proceeding.

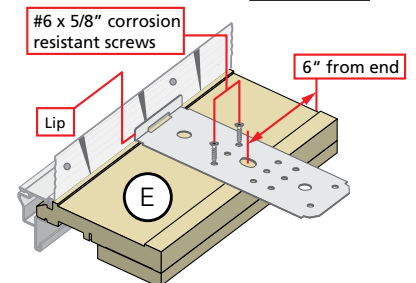
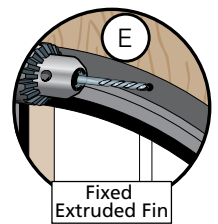
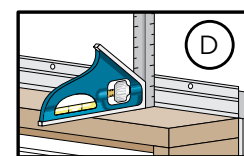
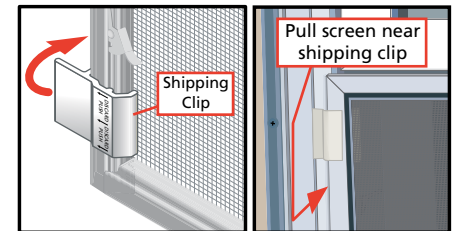

These instructions were developed and tested for use with wall systems designed to manage water. **These instructions are not to be used with any other construction methods or window frame types.** Installation instructions for use with other construction methods or frame types may be obtained from Pella Corporation, your local Pella® retailer or www.installpella.com. Building designs, construction methods, building materials, and site conditions unique to your project may require an installation method different from these instructions and/or additional care. Determining the appropriate installation method is the responsibility of you, your architect, or construction professional.



Always read the Limited Warranty before purchasing or installing Pella® products. By installing this product, you are acknowledging that this Limited Warranty is part of the terms of the sale. Failure to comply with all Pella installation and maintenance instructions may void your Pella product warranty. See Limited Warranty for complete details at www.pella.com/warranty.



NEW CONSTRUCTION INSTALLATION INTO MASONRY CONSTRUCTION

FOR THE INSTALLATION OF NEW NAIL FIN WINDOWS INTO MASONRY OPENINGS WITH WOOD BUCKS

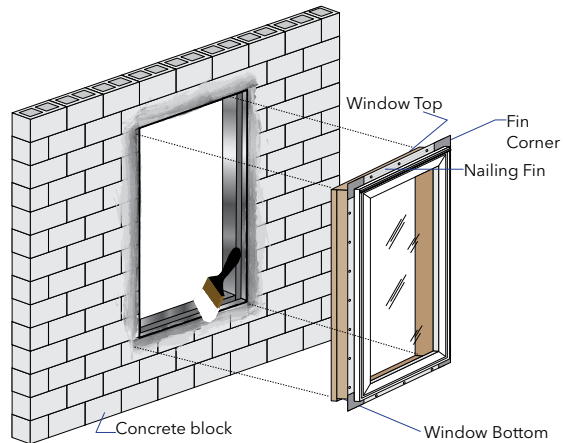
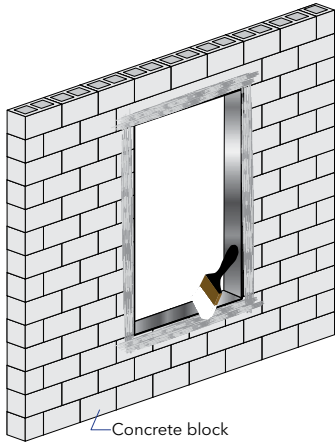

1 PREPARE THE OPENING

Refer to the nail fin installation preparation section at the beginning of this booklet.

- A. **Apply water resistant coating.** Extend the coating into the opening on all four sides and onto the wall surface at least 9". The water resistant coating may be a self-adhered sheet membrane (SASM) or a liquid applied flashing. Ensure continuity between the water resistant coating in the opening and the rest of the wall surface. SASM's must be overlapped in a water shed fashion. Apply all water resistant coatings according to the manufacturer's directions.

NOTE: Allow liquid flashing to dry according to the manufacturer's recommendations.

- B. **Apply 2 beads of sealant** to the masonry opening where the wood buck will be attached.

NOTE: Ensure the sealant is compatible with the water resistant coating.

- C. **Pre-drill and fasten the treated wood buck** to the masonry opening using code-approved fasteners and spacing.

- D. **Apply water resistant coating (optional)** over the wood buck and onto the masonry opening. If using liquid applied flashing, allow it to dry according to the manufacturer's recommendations before proceeding.

- E. **Install and level sill shims.** Place 1" wide x 1/4" to 3/8" thick shims 1/2" from each side. Keep shims back 1/2" from interior face of window. Place additional shims under each mullion and sliding window interlocker.

For vinyl windows, add shims so maximum spacing is 18".

- F. **Attach shims to prevent movement after they are level.**

NOTE: Improper placement of shims may result in bowing the bottom of the window.

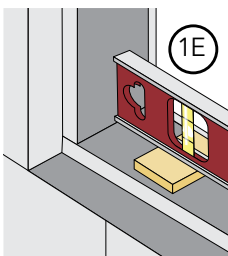
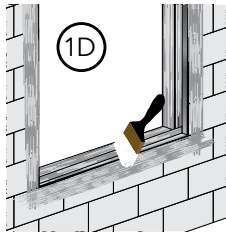
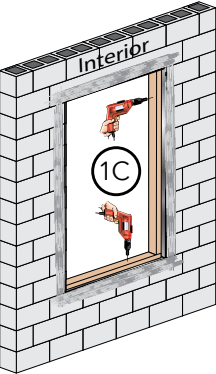
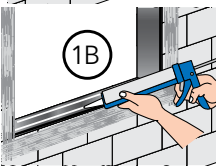
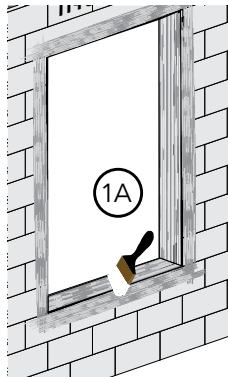

2 SETTING AND FASTENING THE WINDOW

- A. **Insert the window into the opening** on the sill spacers. Center the window between jambs.

- B. **Drive two fasteners**, one near each end of the top nailing fin. See the anchor schedule at the end of this booklet for fastener requirements.

- C. **Plumb and square the window** using shims at the locations shown. Adjust shims to plumb and square the window. Keep shims 1/2" short of window frame depth.

NOTE: DO NOT shim above the window. Additional shims are required at screw locations for large units and combinations. See the nail fin anchor instructions at the end of this booklet.

- D. **Check the window placement by measuring** from the interior surface of the window frame or jamb extension to the interior surface of the wall for consistency. If the dimensions are not equal, confirm the fins are folded fully to 90° (if applicable).

- E. **Drive two fasteners** one near each end of the sill nailing fin.

- F. **Check window operation.**

Vent awning and casement: See lock lever and crank handle instructions at the end of this instruction. Lift the lock lever and turn the crank handle to open the window. Remove the shipping spacers. Open and close the window to test for proper operation.

Double Hung: Cut the checkrail bands (if applicable) and remove shipping spacers. Open, close and tilt the sashes to test for proper operation. Check for equal sash to frame reveal from top to bottom.

NOTE: Adjust shims to correct any issues with plumb, square, operation or reveal.

- G. **Close and lock the window.**

- H. **Finish driving fasteners into the nailing fin.** Refer to the nail fin anchor instructions at the end of this booklet.

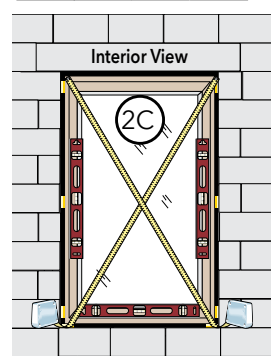
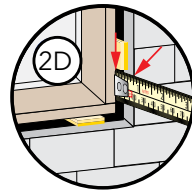
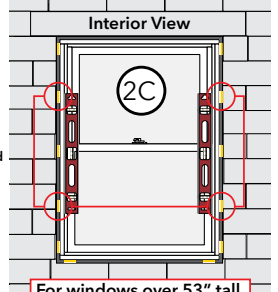
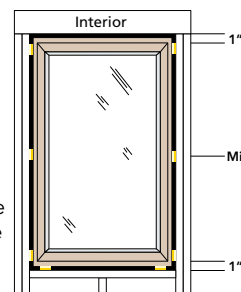
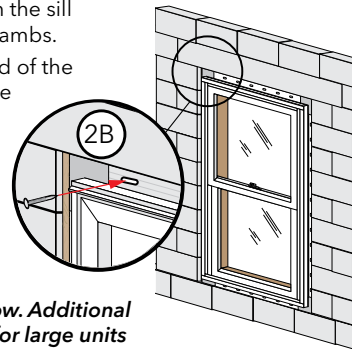



NEW CONSTRUCTION INSTALLATION INTO MASONRY CONSTRUCTION (CONTINUED)

FOR THE INSTALLATION OF NEW NAIL FIN WINDOWS INTO MASONRY OPENINGS WITH WOOD BUCKS

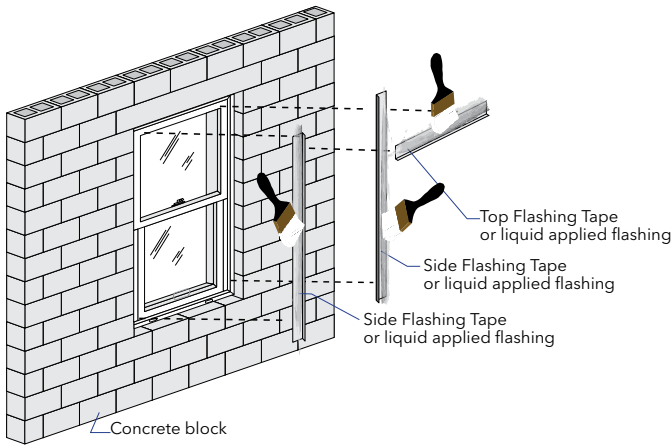

3 SEALING THE TOP AND SIDE NAILING FINs

NOTE: Apply flashing tape or liquid applied flashing 1/2" onto frame cladding with fold-up or slide-in fins. Pre-fold flashing tape at 1/2" to assist with application. For siding less than 1/2" thick, adjust the placement of the tape to allow the exterior sealant to cover the tape edge.

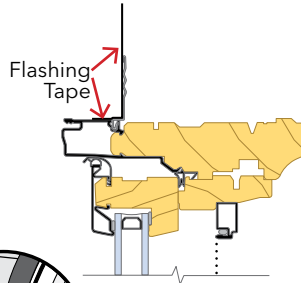

Curved and angle top units without pre-applied fin corners:

A. Cut four 1-1/2" long pieces of flashing tape.

Apply one to each end of sill fin to extend it 1-1/2" past each jamb.

B. Apply one to the bottom end of each jamb fin beginning 1-1/2" from the end of the fin and lapping over the first piece of flashing tape.

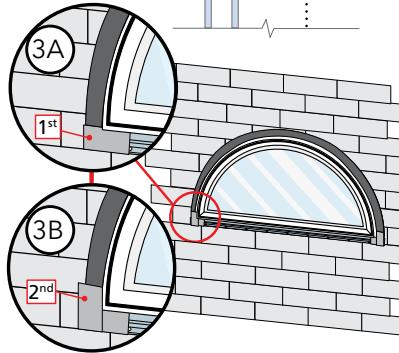

If liquid applied flashing was used to prepare the opening, apply it over the nail fin at jambs and head at this time according to the manufacturer's instructions. Leave the sill nailing fin uncovered. Skip to step 3E.

If the opening was prepared using SASM, follow steps C-D.

C. Apply straight side flashing tape. Cut two pieces of flashing tape 4" taller than straight sides. Apply tape over the fin and onto liquid applied flashing or SASM. Extend tape 2" above and below straight sides.

Angle top Units: On the short side, do not allow the side tape to extend higher than what the top tape will cover.

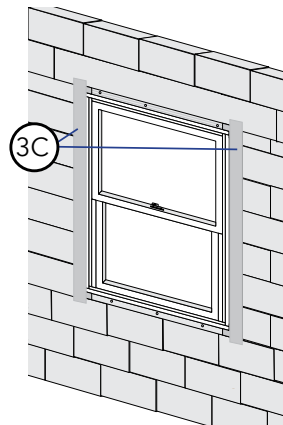
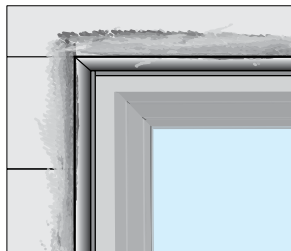

D. Apply top flashing tape.

Rectangular Units: Cut one piece of flashing tape to extend 1" past both side flashing tapes.

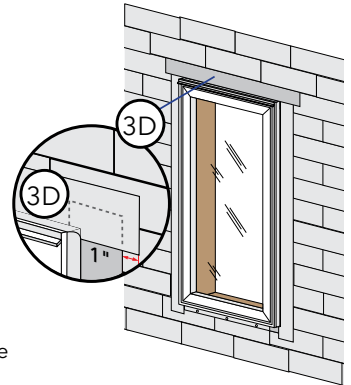

Curved Top Units: Using several short pieces, start taping from the sides of the window working towards the peak. Cut each piece short enough so each piece overlaps the previous piece. Tighter curved frames will require shorter pieces of tape.

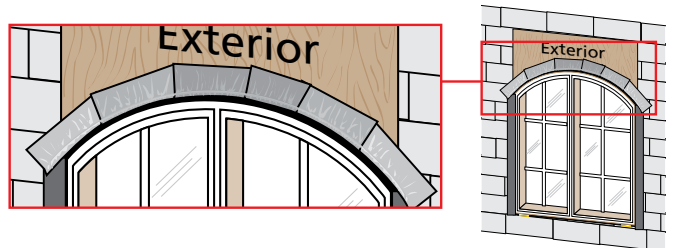

NOTE: DO NOT TAPE OVER BOTTOM NAILING FIN.

NOTE: PRESS ALL FLASHING TAPE DOWN FIRMLY.

Apply SASM or liquid applied water management system in watershed fashion with head flashing and in accordance with manufacturer's recommendations.

E. Install interior sealant. Refer to the interior sealant instructions at the end of this booklet.

F. Install head flashing, properly incorporating it with the siding and water management system according to applicable code requirements.

G. Install exterior sealant. (After wall cladding is installed) Refer to the exterior sealant instructions at the end of this booklet.

NOTE: Frame curved portions of rough opening to support window and wind loads (if applicable).



NAIL FIN WINDOW ANCHOR INSTRUCTIONS

Note: Standard performance only. Additional anchoring may be required for performance upgrade, impact resistant products or to comply with local building code requirements.

PLACE FASTENERS AT THE LOCATIONS INDICATED.

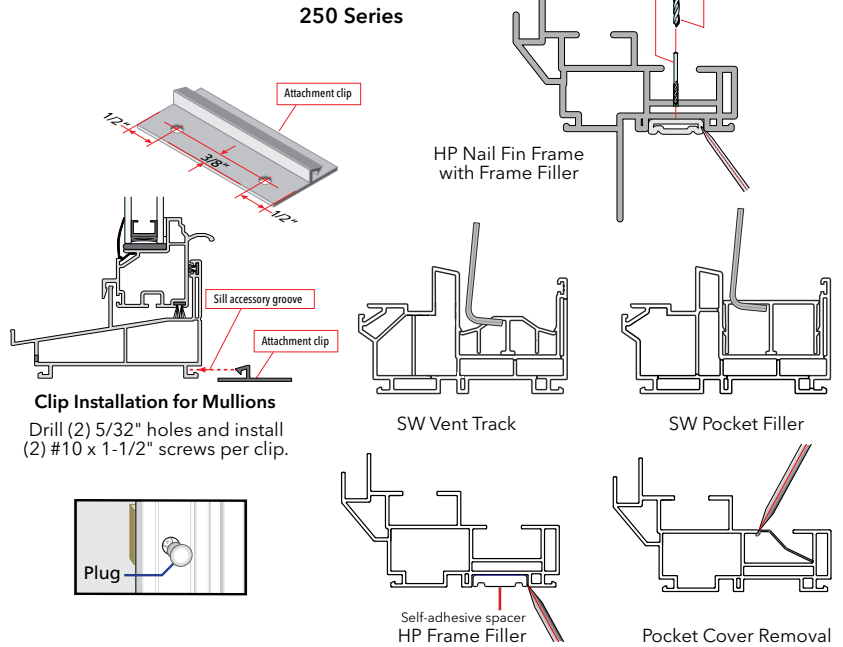
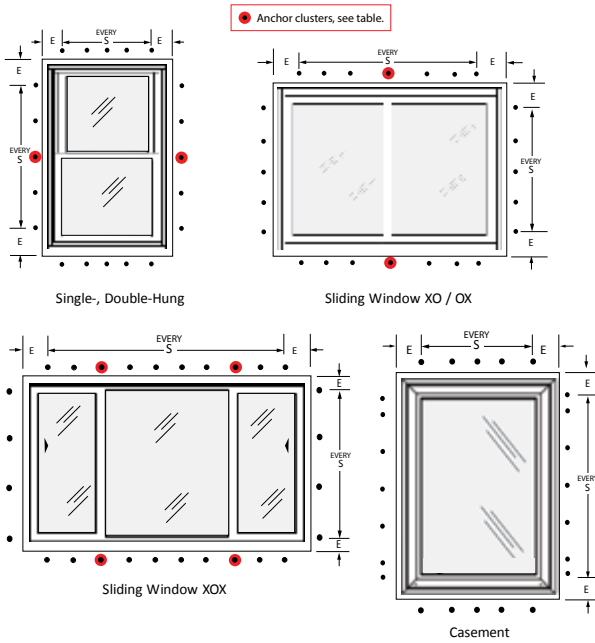

ENCOMPASS BY PELLA®/THERMASTAR BY PELLA® / PELLA® 250 SERIES AND PELLA® 350 SERIES WINDOWS

Product	PG Rating	Max Frame Width (inches)	Max Frame Height (inches)	Edge Spacing (E)	Max. Intermediate Spacing (S)	Anchor Type		Anchor Cluster
						Wood *		
Encompass and ThermaStar Windows	< 50	Any	Any	Every Other Pre-Punched		2" 11 Ga. Roofing Nail		Additional nails at 3" and 6" on both sides of the transition mullion at head and sill.
	50	Any	Any	Every Pre-Punched Hole		#8 x 2" Screw with Washer		** High Performance DH: (3) #10 x 2" jamb frame screws, 4" apart at checkrails. Use (4) #10 x 2" screws at head mullion ends and 4 clips at sill mullion ends 3" and 6" from mullion.
250 Series	Windows	< 50	Any	Any	Every Other Pre-Punched Hole	1.5" 11 Ga. Roofing Nail		High Performance DH: (3) #8 x 2" jamb frame screws, 4" apart at checkrails. Use (4) #8 x 2" screws at head mullion ends and 4 clips at sill mullion ends 3" and 6" from mullion.
	SH/SW/FX	50	Any	Any	Every Pre-Punched Hole	1.5" 11 Ga. Roofing Nail		
	DH	50	Any	Any	Every Pre-Punched Hole	#10 x 2" Screw with Washer		** 3 jamb frame screws, 4" apart at Checkrails 3 - #10x2" screws, 2" apart at Mullion Ends
350 Series	SH and DH	30	40"	63"	6"	8"	1.5" 11 Ga. Roofing Nail	None
		40	40"	63"	6"	8"	1.5" 11 Ga. Roofing Nail	5 nails, 2" apart at Checkrails
		+40/-60	Any	Any	6"	8"	1.5" 11 Ga. Roofing Nail	5 nails, 2" apart at Checkrails and Mullion Ends
	2-Panel Sliding Windows	30	76"	48"	6"	8"	1.5" 11 Ga. Roofing Nail	None
		40	76"	62"	6"	8"	1.5" 11 Ga. Roofing Nail	5 nails, 2 inches apart Meeting Stiles
		+40/-60	76"	72"	6"	8"	#10 x 2" Screw with Washer	3 Screws, 2" apart at Meeting Stiles
	3-Panel Sliding Windows	30	123"	48"	6"	8"	1.5" 11 Ga. Roofing Nail	None
		40	123"	62"	6"	8"	1.5" 11 Ga. Roofing Nail	5 nails, 2" apart at Meeting Stiles
		All Other	Any	Any	6"	8"	#10 x 2" Screw with Washer	5 Screws, 2" apart at Meeting Stiles
	CM, AW, FX	40	Any	Any	6"	8"	1.5" 11 Ga. Roofing Nail	None
60		Any	Any	4"	4"	1.5" 11 Ga. Roofing Nail	None	
FX Composites	All	Any	Any	4"	4"	1.5" 11 Ga. Roofing Nail	5 nails, 2" apart at Mullion Ends	

* For light gauge steel framing, use #10 self-drilling modified truss head screws.

** High Performance Frame Fillers are required at each jamb anchor location.

NOTE: Do not over-drive fasteners, but allow for movement of building materials.

Refer to the supplemental instruction included with the unit for securing mullion end anchors (if applicable).

When screws are used in the Nail-Fin, a 1" fender washer is required at each screw anchor location.



NAIL FIN WINDOW ANCHOR INSTRUCTIONS (CONTINUED)

Note: Standard performance only. Additional anchoring may be required for performance upgrade, impact resistant products or to comply with local building code requirements.

PELLA® IMPERVIA, ARCHITECT SERIES® (850), DESIGNER SERIES® (750) AND PELLA® 450 SERIES NAIL FIN ANCHOR SPACING INSTRUCTIONS

Product	PG Rating	Max Frame Width (inches)	Max Frame Height (inches)	Edge Spacing (E)	Max. Intermediate Spacing (S)	Anchor Type	
						Wood *	Frame Anchors
Impervia Windows	All	Any	Any	3"	7"	2" 11 Ga. Roofing Nail	None
450, 750 and 850 Clad Wood CM, AW or FX Windows	All	73"	73"	Every Pre-Punched		2" 11 Ga. Roofing Nail	None
	All	>73"	>73"	Every Pre-Punched Hole		2" 11 Ga. Roofing Nail	#10 x 3-1/2" Screws at 1/3 points along head and jambs
450, 850 SH or DH Windows	All	Any	Any	Every Pre-Punched Hole		2" 11 Ga. Roofing Nail	None
Monumental DH	All	<54	<96	Every Pre-Punched Hole		1-1/2" 11 Ga. Roofing Nail	refer to the next page for units larger than 54 x 96
750 DH Windows	≤ 30	Any	Any	Every Pre-Punched Hole		1-1/2" 11 Ga. Roofing Nail	None
	>30	Any	Any	Every Pre-Punched Hole		#8 x 2" Screw with washer	None
Clad Wood Curved Shape Windows with Flexible Fin or Wide EnduraClad Exterior trim with narrow fin.	All	Any	Any	6"***	16"***	(2) #6 x 1-1/2" screw** per clip	(2) #6 x 5/8" holding each clip** to the window frame
Clad Wood Curved Windows with Rigid Fin	All	Any	Any	6"	12"	2" 11 Ga. Roofing Nail	None

* = For light gauge steel framing, use #10 self-drilling modified truss head screws.

** Refer to the Pella® EnduraClad® Exterior trim with narrow nailing fin anchoring instructions.

NOTE: Do not over-drive fasteners in vinyl fins, but allow for movement of building materials.

Refer to the supplemental instruction included with the unit for securing mullion end anchors (if applicable).

Clad wood direct set windows achieve PG50 up to 60" x 60" with standard anchoring. Larger sizes achieve PG40. Refer to advanced performance/ impact resistant instructions for other options.

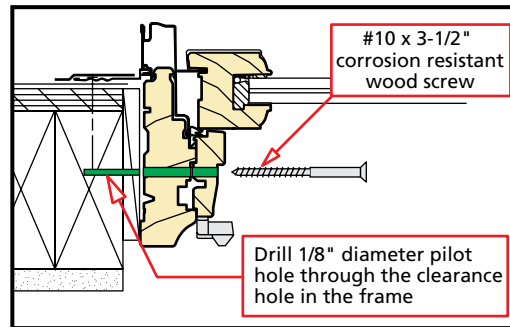
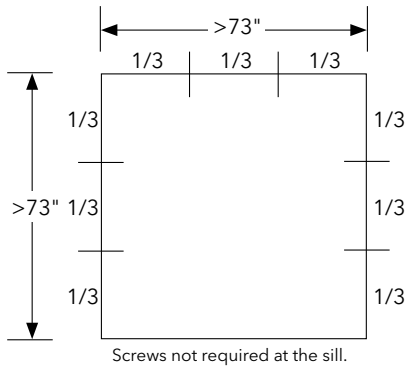

Add frame anchor screws for vent and fixed clad-wood casements over 73"

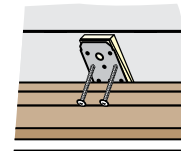
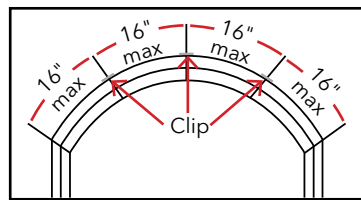
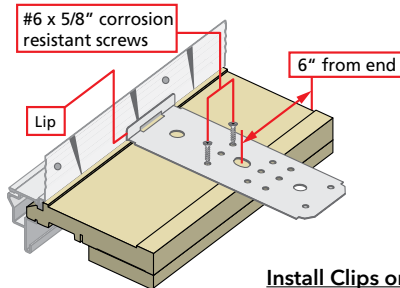

Install Clips or frame screws for windows with non-structural curved flex fins

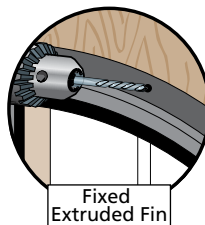

Drill 1/8" diameter Holes for windows with curved rigid fins



UNITS WITH WIDE PELLA® ENDURACLAD® EXTERIOR TRIM WITH NARROW FINNS AND NO PRE-PUNCHED HOLES ANCHOR INSTRUCTIONS AND MONUMENTAL HUNG > 54" X 96"

Note: Standard performance only. Additional anchoring may be required for performance upgrade, impact resistant products or to comply with local building code requirements.

Units with narrow fins and NO pre-punched holes must be anchored using frame screws or installation clips. These fins are for flashing purposes only.

PLACE FRAME SCREWS OR CLIPS AT THE LOCATIONS INDICATED

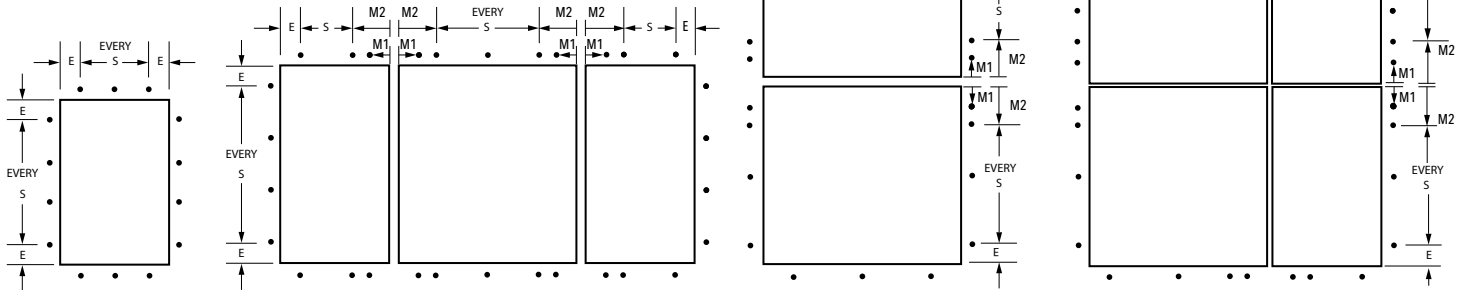

ARCHITECT SERIES® (850), DESIGNER SERIES® (750) AND PELLA® 450 SERIES WINDOW ANCHOR SPACING INSTRUCTIONS

Product	Edge Spacing (E)	Max. Intermediate Spacing (S)	First Mullion Anchor (M1)	Second Mullion Anchor (M2)	Fastener	Special Notes
					Wood **	
Casement/Awning	6"	16"	3"*	6"	#8x3" Finish Screw	
Double- or Single- Hung	6"	16"	3"*	6"	#8x3" Finish Screw	
Fixed Frame	6"	16"	3"*	6"	#8x3" Finish Screw	
Monumental DH > 54" x 96"	6" (head)	16" (head)	3" *	6" *	#8 x 3" Screw	Remove sashes and jamb liners. Drive 1 screw through each jamb liner support clip (top, bottom, checkrail and center of each sash). Drive 2 additional screws through the frame (or secure clips) 3" above and below the checkrail on each jamb. Drive additional screws through the frame (or secure clips) centered between each jamb liner support clip.

* M1 anchor required if design pressure exceeds 20 psf.

** For light gauge steel framing, use #10 self-drilling/self-tapping screws; For concrete or masonry, use 3/16" masonry screws with 1-1/4" minimum embedment.

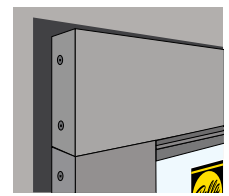

Exterior trim with narrow fin

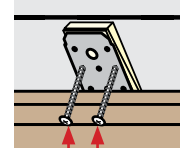

#6 x 1-1/2" screw

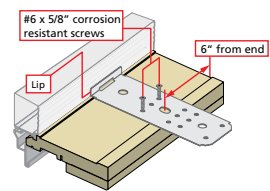

#6 x 5/8" corrosion resistant screws

6" from end

1/8" Pilot Hole Locations

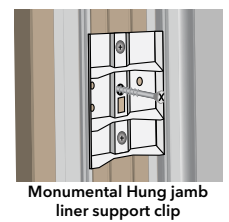
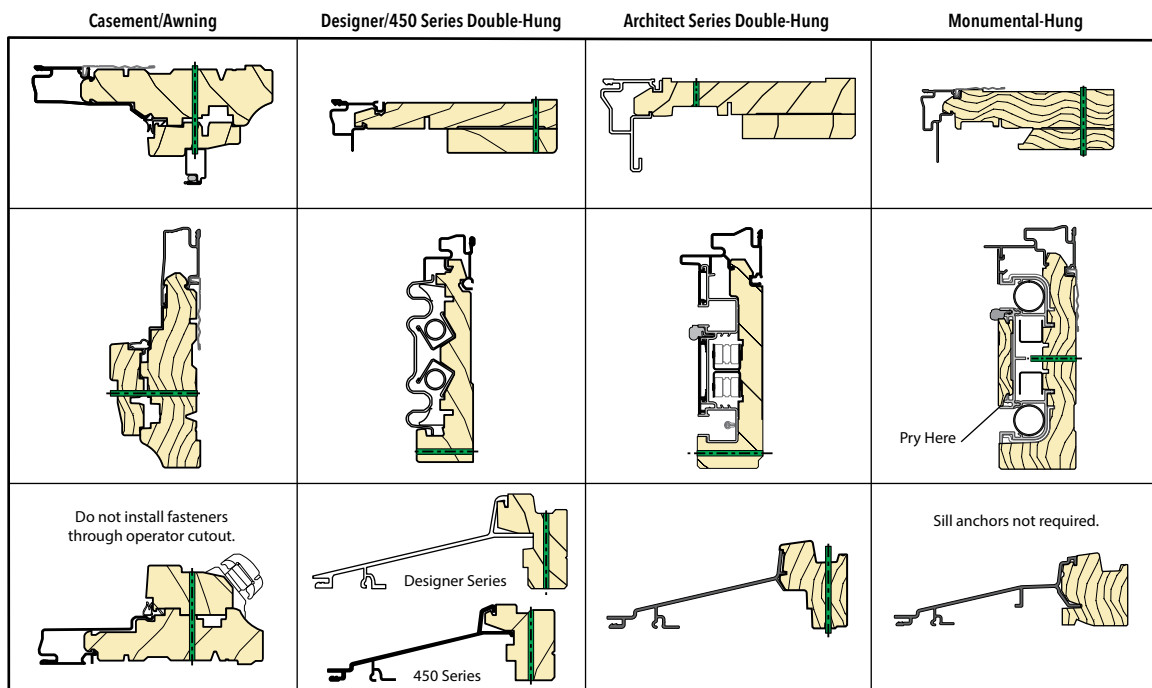

Monumental Hung jamb liner support clip

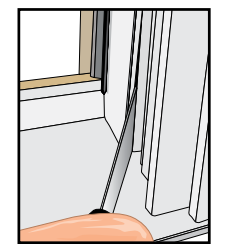

Pry off Monumental Double-Hung jamb liner

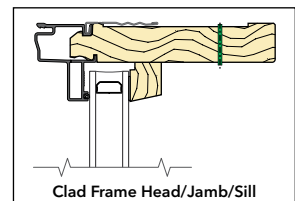

Clad Frame Head/Jamb/Sill



Interior Sealant Instructions

CAUTION: Use low pressure polyurethane window and door insulating foams. Follow the directions on the can. Do not use high pressure or latex foams.

- A. Insert the nozzle or straw between the rough opening and window frame from the interior. Use a pliers (if necessary) to compress the end of a straw tube to allow it to fit in tight openings.
- B. Place a 1" deep bead of foam approximately 1" from the interior of the frame to allow for expansion. DO NOT fill the entire depth of the rough opening cavity.
NOTE: Apply foam between the frame and rough opening, NOT between jamb extensions and the rough opening.

- C. To ensure a continuous interior seal, apply sealant over the interior surface of any shims or clips interrupting the foam seal.

Backer rod (as necessary) and sealant can be used in place of the low expansion foam to create the interior seal. However, foam has greater insulating properties. Fiberglass batt or similar insulation is not recommended as it can absorb water and does not act as an air seal.

NOTE: Use a low odor, paintable sealant such as Pella Window and Door Installation Sealant.

Re-check window operation and remove shipping spacers after foam installation. Excess foam may be removed with a serrated knife after it cures.

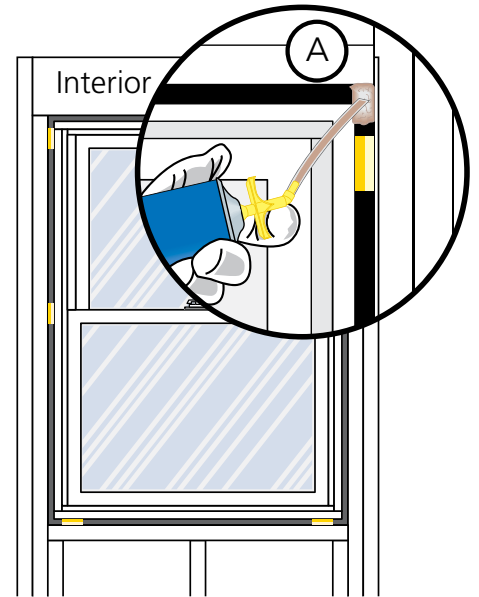

Exterior Sealant Instructions

CAUTION: Use a high quality, multi-purpose exterior sealant such as Pella Window and Door Installation Sealant. Follow the directions on the cartridge.

When applying siding, brick veneer, flashing, or other exterior finish materials, leave adequate space between the window frame and the material for sealant application.

- A. Insert backer rod 3/8" deep in the space around the window. Backer rod adds shape and controls the depth of the sealant line.
- B. Apply a continuous bead of sealant to the entire perimeter of the window.
- C. Shape, tool and clean excess sealant. When finished, the sealant should be the shape of an hourglass.

NOTE: The siding details below apply to windows without a J-mould as part of the frame. The J-mould frame is only intended for vinyl or metal sidings where the siding is extended behind the J-mould portion of the frame. The J-mould should be removed and replaced with backer rod and sealant with all other siding or trim types.

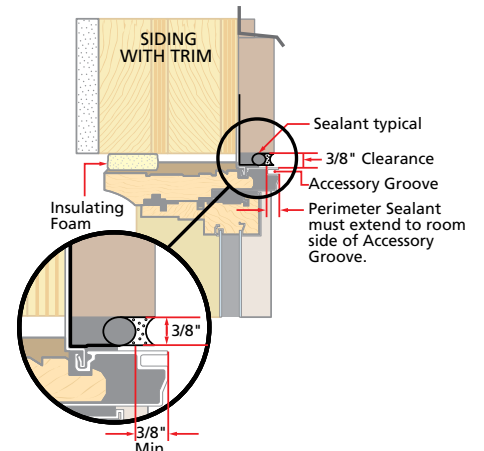
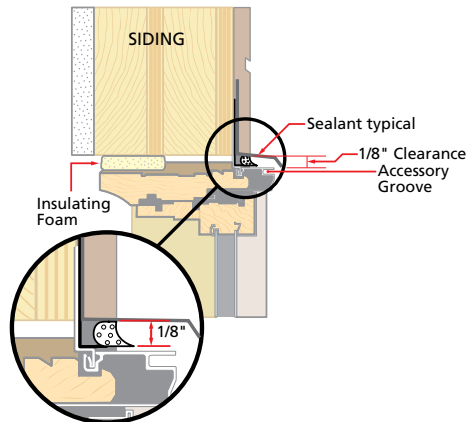
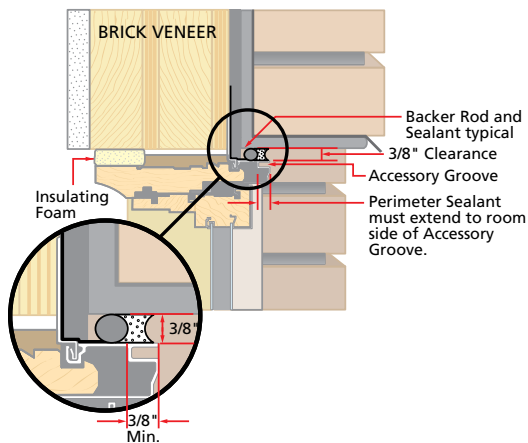
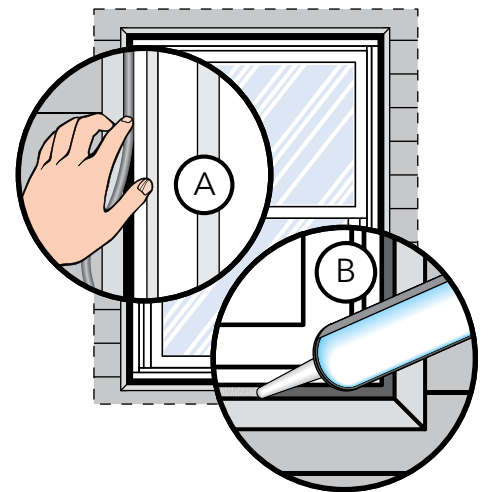



INSTALLING ROTO COVER AND CRANK

Note: Finish the interior of the window and allow the window to dry before proceeding with these instructions. (To open the window for finishing, partially insert the lock handle into the jamb, unlock the unit, temporarily attach the crank handle and turn to open.)

- Place the cover over the operator stud and snap into place. Position the pocket end of the cover into place.
Note: If the cover does not have the screw hole, apply pressure on the pocket end of the cover to snap the cover into place and proceed to step C.
- Insert the provided screw into the hole in the bottom of the pocket. Use a # 1 Phillips screwdriver to secure the pocket screw snug against the bottom of the pocket to avoid scratching the crank handle knob. DO NOT over tighten.
- Use a medium size flat-blade screwdriver to loosen the set screw in the crank handle.
- Slide the crank handle onto the stud. Unlock, open window, then close and lock window.
- Fold the crank handle down and check alignment of knob with the pocket.
Note: You may need to adjust the crank position on the stud until the correct alignment is achieved.
- Open the crank and tighten the set screw.
- After the final installation, fold the crank over and snap the knob into the pocket.

Note: Even with the window open the crank can be folded to avoid interfering with the window treatments.

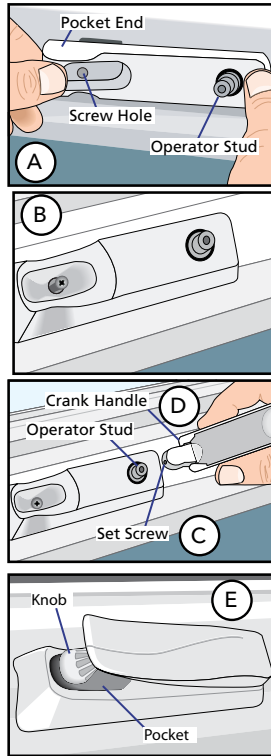

LOCK LEVER INSTALLATION AND REMOVAL

- Unlock and open the window.
- Place the lock lever in the locked position.
- From the exterior of the window, insert a small flat-blade screwdriver into the slot behind the lock lever.
- Pry the cam away from the side of the window by rotating the screwdriver a quarter turn. This will release the hook in the lever from the cam hook.
- Remove the lock lever by pulling it toward the interior of the building.
- To install a lock lever, hold it in the lock position and insert it, from the interior, into the slot until it snaps into the cam.

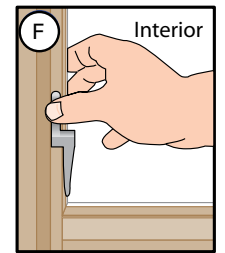
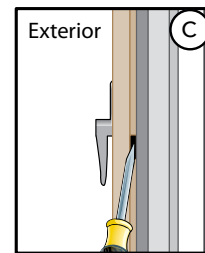
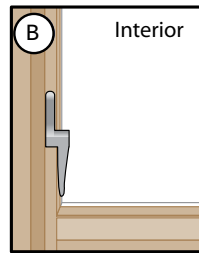
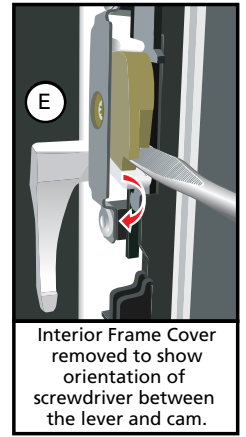

Exterior Finish of Existing Frame (Pocket Replacement)

It is the responsibility of the homeowner, contractor or installer to ensure any exposed unfinished wood is covered or finished. Possible methods include, however are not limited to, covering with aluminum coil stock or painting.

Cleaning Instructions

GLASS—Remove any protective film and labels and clean the glass, using a soft, clean, grit-free cloth and mild soap or detergent. Be sure to remove all liquid by wiping dry or use a clean squeegee.

Pella® ALUMINUM CLAD OR IMPERVIA FRAMES—The interior and exterior frame and sash are protected with a tough factory finish. Clean this surface with mild soap and water. Stubborn stains and deposits may be removed with mineral spirits. DO NOT use abrasives. DO NOT scrape or use tools that might damage the surface.

Encompass by Pella®/Thermastar by Pella® and Pella® 350 Series Windows FRAMES—The vinyl frame may be cleaned using the same method as the glass. For stubborn dirt, a “non-abrasive” cleaner such as Bon-Ami® or Soft Scrub® may be used. Do not use solvents such as mineral spirits, toluene, xylene, naphtha or muriatic acid as they can dull the finish, soften the vinyl and/or cause failure of the insulated unit seal. Keep door tracks clear of dirt and debris. Keep weep holes open and clear of obstructions.

Use of inappropriate solvents, brickwash or cleaning chemicals will cause adverse reactions with window and door materials and voids the Limited Warranty.

Interior Finish (Wood Windows)

If products cannot be finished immediately, cover with clear plastic to protect from dirt, damage and moisture. Remove any construction residue before finishing. Sand all wood surfaces lightly with 180 grit or finer sandpaper. DO NOT use steel wool. BE CAREFUL NOT TO SCRATCH THE GLASS. Remove sanding dust. Pella products must be finished per the below instructions; failure to follow these instructions voids the Limited Warranty.

- On casement and awnings, it is optional to paint, stain or finish the vertical and horizontal sash edges.
- On single-hungs and double-hungs, do not paint, stain or finish the vertical sash edges, any finish on the vertical sash edges may cause the sash to stick; it is optional to paint, stain or finish the horizontal sash edges.

Note: To maintain proper product performance do not paint, finish or remove the weatherstripping, mohair dust pads, gaskets or vinyl parts. Air and water leakage will result if these parts are removed. After finishing, allow venting windows and doors to dry completely before closing them.

Pella Corporation is not responsible for interior paint and stain finish imperfections for any product that is not factory-applied by Pella Corporation. For additional information on finishing see the Pella Owner's Manual or go to www.pella.com.

Care and Maintenance

Care and maintenance information is available by contacting your local Pella retailer. This information is also available at www.pella.com.

IMPORTANT NOTICE

Because all construction must anticipate some water infiltration, it is important that the wall system be designed and constructed to properly manage moisture. Pella Corporation is not responsible for claims or damages caused by anticipated and unanticipated water infiltration; deficiencies in building design, construction and maintenance; failure to install Pella products in accordance with Pella's installation instructions; or the use of Pella products in wall systems which do not allow for proper management of moisture within the wall systems. The determination of the suitability of all building components, including the use of Pella products, as well as the design and installation of flashing and sealing systems are the responsibility of the Buyer or User, the architect, contractor, installer, or other construction professional and are not the responsibility of Pella.

Pella products should not be used in barrier wall systems which do not allow for proper management of moisture within the wall systems, such as barrier Exterior Insulation and Finish Systems (EIFS) (also known as synthetic stucco) or other non-water managed systems. Except in the states of California, New Mexico, Arizona, Nevada, Utah and Colorado, Pella makes no warranty of any kind on and assumes no responsibility for Pella windows and doors installed in barrier wall systems. In the states listed above, the installation of Pella Products in barrier wall or similar systems must be in accordance with Pella's installation instructions.

Product modifications that are not approved by Pella Corporation will void the warranty.