



Natatorium Design Guide

Table of Contents

Introduction	3	Finalizing System Design	19
Comfort, Health and Safety	4	Key Design Concerns for Traditional Pools	19
Comfort and Health.....	4	Step 1: Operating Conditions	19
Humidity Control Calculations	5	Step 2: Supply Air	19
Load Calculation.....	5	Step 3: Outdoor Ventilation Air per Standard 62-2004	19
Pool Evaporation.....	5	Step 4: Exhaust Air	20
Occupant Load.....	6	Step 5: Load Calculations.....	20
Outdoor Air	6	Step 6: Condensation and Vapor Migration	20
Load Estimation Software	6	Step 7: Energy & LEEDs Considerations	20
Humidity Control Technology	7	Popular Configurations and System Designs ..	21
How to Remove Moisture	7	Hotel and Residential Market.....	21
Refrigeration Based Dehumidifiers.....	7	Purge – Economizer Layout	22
Chilled Water with Reheat Air Handler.....	8	Dehumidifier Specification	24
Outdoor Air Ventilation Systems	8	Service Vestibule	24
Indoor Air Quality	9	Microprocessor Control.....	24
Pool Water Chemistry	9	WebSentry	24
Chlorine Smell.	9	Refrigerant Pressure Transducers	25
Pool Water pH Levels	10	Refrigerant System Charges	25
Total Dissolved Solids	10	Receiver Refrigerant Level Indicators.....	25
Humidity and Corrosion.....	10	Direct Drive Plenum Fans with VFD	25
Outdoor Ventilation Air	10	Coated Airside Coils	25
Exhaust Air	10	Warranty	25
Air Change Rate	11	Commissioning	25
Condensation Control	11	First Year Labor	25
Dew Point Temperature.....	12	Design Installation Details	26
Vapor Retarder	12	Access Space.	26
Window Design.....	13	Pool Water Heating (Option)	26
Air Distribution.....	13	Outdoor Air Cooled Dry Cooler and Condenser Installation	26
Energy Consumption Considerations	15	Control Wiring	29
Operating Conditions	15	Frequently Asked Questions	30
Pool Water Heating Energy Recovery	15		
Space Heating	16		
Space Cooling	16		
Outdoor Air, Exhaust Air and Energy Recovery . .	16		

Natatorium Design – Introduction

The natatorium experience for a patron should be no different to any other room in a building. It should be comfortable, healthy and have good air quality. When designing a natatorium the relative humidity, air temperature, pool water temperature, pool activity levels, air distribution, outdoor air, exhaust air and pool water treatment are all key aspects that must be addressed to provide a good environment.

While 50-60% relative humidity levels are ideal for bather comfort and health they can lead to condensation problems and serious damage to the building structure. If the building structure itself has not been properly designed for this higher humidity application catastrophic results may occur.

Comfort, Health and Safety

A natatorium is one of the most notoriously difficult facilities to design because there are so many critical considerations that, if overlooked, can develop into problems with the building structure or into complaints from the occupants. The designer must take a complete system approach, from basic engineering issues to the more subtle details in the air distribution. Experience and a complete understanding of the design issues help the designer satisfy:

- Comfort and health
- Humidity control
- Indoor air quality
- Condensation control

Comfort and Health

Temperature and relative humidity play a critical role in human comfort levels. It is essential that both are controlled and stable. While temperature control is generally well understood and mastered by designers, it is important to recognize the temperature levels natatorium patrons expect. The space temperatures in a natatorium are unique to each project and assumptions must never be made.

Proper control of relative humidity levels are also a concern because of the direct effect on human comfort and health. Figure 1 shows that relative humidity levels outside the optimum zone 40%-60% range can result in human vulnerability to disease. These diseases include bacteria, viruses, fungi, mites and other contaminants that lower air quality and will potentially lead to respiratory issues.

While 40% is certainly an acceptable indoor relative humidity level, most indoor pools do not operate at lower than 50% RH due to significantly increased operating costs.

- At lower RH levels, the pool evaporation rate increases dramatically. This increases both the dehumidification load and the pool water heating requirement.
- In cold climate applications it is important to ensure no more outdoor air be introduced than what the

codes require. More is not better in this case as it causes the RH levels can plummet to as low as 20%, costing the operator in dearly in increased air and pool water heating costs.

- Swimmers leaving the water feel chilly at lower relative humidity levels due to evaporation off their bodies.

Figure 1 – Relative Humidity Impacts Occupant Health

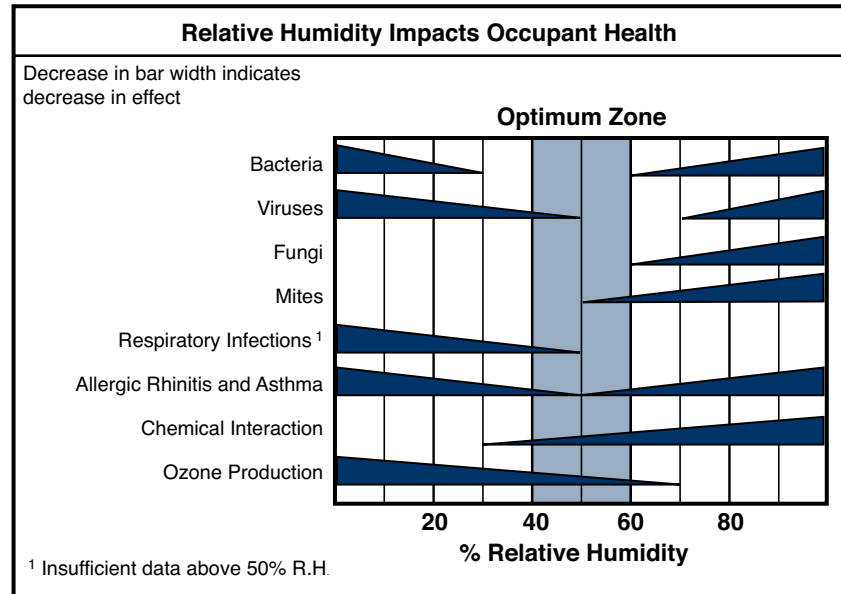

Study by Theodore Sterling Ltd., A. Arundel Research Associates and Simon Fraser University.

The type of facility being designed will typically dictate the space temperature. Table 1 helps target some typical conditions. It is critical to understand who will be using the facility in order to deliver the conditions most likely to satisfy them.

Table 1 – Natatorium Design Conditions

Typical Natatorium Design Conditions		
Pool Type	Air Temperature (°F)	Water Temperature (°F)
Competition	75 to 85	76 to 82
Diving	80 to 85	84 to 88
Elderly Swimmers	84 to 85	85 to 90
Hotel	82 to 85	82 to 86
Physical Therapy	80 to 85	90 to 95
Recreational	82 to 85	80 to 85
Whirlpool/spa	80 to 85	102 to 104

General Notes:

- Facilities with warmer water temperatures tend to have warmer space temperatures.
- Physical Therapy facilities will often cater to therapist comfort rather than the patient. The patient is generally not in the space for more than an hour, whereas the therapist is there all day. The designer

should consult local codes. Some States require a full purge of the clinic room air with 100% outdoor air for every hour of occupancy.

- Elderly swimmers tend to prefer much warmer air and water temperatures.
- Maintain Relative Humidity between 50% & 60% RH. Do not go below 50%.

Humidity Control Calculations

As mentioned previously, 50-60% relative humidity levels are ideal for bather comfort but they can lead to condensation problems and serious damage to the building structure. If the building structure itself has not been properly designed for this higher humidity application catastrophic results may occur. The Architect should design and protect the building enveloped based on an indoor dew point design condition.

Controlling humidity to provide this stable dew point condition year round requires that a total moisture load be accurately calculated. This moisture load must be removed from the space at the same rate it is generated in order to maintain stable space conditions.

Load Calculation

Every building's moisture (latent) load is calculated in the same way. There are generally three sources of moisture that are considered:

- Internal load (pool evaporation)
- Occupants
- Outdoor air load

Pool Evaporation

The internal load in a natatorium is the evaporation from the pool water and wet deck surfaces. In a natatorium this represents the majority of the total dehumidification load. Consequently, it is essential to accurately predict the pool evaporation.

There are 5 variables used to calculate the evaporation rate:

- Pool water surface area
- Pool water temperature
- Room air temperature
- Room air relative humidity
- Pool water agitation and Activity Factor

The first four variables are straightforward and should be dictated by the owner. They are used to

calculate the baseline (unoccupied) evaporation rate in the natatorium.

The Activity Factor is the fifth variable. It is a water agitation factor. The Activity Factor is used to evaluate how much water agitation and splashing is expected when the pool is in use and how that increases the evaporation from the baseline value. Chapter 4 of ASHRAE's 2011 HVAC Applications Handbook publishes an Activity Factor table (Table 2) based on years of empirical field and test data.

Table 2 – Activity Factors

Type of Pool	Activity Factor
Elderly swim	0.65
Fitness club – Aquafit	0.65
Hotel	0.8
Institutional - School	0.8 – 1.0
Physical Therapy	0.65
Public / YMCA	1.0
Residential	0.5
Swim Meet	0.65
Wave Pool	1.5 – 2.0
Whirlpool	1.0

Evaporation Rate Equation:

Equation #2 in chapter 4 of ASHRAE's 2011 HVAC Applications Handbook calculates the evaporation rate in pounds of water per hour (lb/h) for air velocity over water @ 10-30 fpm. The Vapor Pressure values can be found in steam tables.

$$ER = 0.1 \times A \times AF (P_w - P_{dp})$$

ER = evaporation Rate of water, lb/h

A = area of pool water surface, ft²

AF = Activity Factor (see Table 2)

P_w = saturation vapor pressure at water surface, in. Hg

P_{dp} = partial vapor pressure at room dew point, in. Hg

It can be seen from the equation that the following factors increase the evaporation rate:

- Increasing water temperature
- Lowering air temperature
- Lowering air relative humidity
- High activity/agitation

Once equipment has been selected and installed, any change of the variables that increases the evaporation rate can result in equipment no longer being suitable for the new larger load.

Occupant Load

Swimmers are not usually considered occupants as they are submerged in the water. Swimmers and their water agitation are included in the Activity Factor. Spectators, especially in facilities that host swim meets can total several thousand, and add a significant moisture load, (see Table 3).

It is important to understand that when a facility is hosting a swim meet the Activity Factor of the water is considerably reduced. Typically there is only one swimmer per lane and while they agitate the water considerably, the overall agitation is much less than a densely occupied pool during a public swim.

Table 3 – Occupants Latent Load

Activity Level	Lb/h per Spectator
Quietly Seated	0.155
Moderate Activity	0.205
Enthusiastic	0.250
Highly Enthusiastic	0.530

To evaluate the dehumidification load during swim meets an Activity Factor of 0.65 is used to calculate the evaporation rate. The total number of spectators and competitors on the pool deck must also include in the load. Codes also generally require that each spectator be provided with 7.5 CFM of outdoor air. The load impact of the outdoor air must also be calculated.

Seresco recommends that facilities hosting swim meets size equipment based on the larger of the two main operating modes, normal operation load or swim meet load.

Outdoor Air

The introduction of outdoor air is essential to maintaining good air quality in any facility. The impact of this outdoor air ventilation on a natatorium changes with the weather and the geographic location of the facility. Introducing outdoor air during the summer generally adds moisture to the space and in the winter removes moisture from the space. For maximum dehumidification load calculations the Summer Design conditions are considered.

Construction codes generally require that outdoor air be introduced into a commercial building during occupied hours. ASHRAE Standard 62-2004 Table 6.1 recommends the introduction of outdoor air into a natatorium at the following rates:

- 0.48 CFM/ft² of pool and (wet) deck area as base line
- 7.5 CFM per spectator added to the base line during swim meets

ASHRAE interprets the wet deck area as no more than six foot perimeter around the pool. The purpose of this outdoor air is to help dilute chemicals off-gassed from water. A predictably dry portion of the deck will not factor into the IAQ issues. Additionally, outdoor air requires considerable heating in the winter.

More is not better. Exceeding code requirements is not recommended. In winter it will significantly increase the operating expenses and in summer may increase the dehumidification load.

Load Estimation Software

Seresco has developed software that calculates all moisture loads in a matter of minutes. Figure 2 gives a snapshot of the basic data that would generally need to be entered to calculate a load.

Figure 2 – Sample of Seresco's Load Estimating Software

The screenshot shows the 'Natatorium Design' software interface. It is organized into several sections:

- POOLS:** A table with columns for Pool Name, Surface Area (ft²), Water Temp (°F), and Activity Factor. It lists 'Main Pool' (2000 ft², 84°F, 0.8) and 'Spa' (120 ft², 104°F, 1.0). Buttons for 'Add Pool', 'Remove', and 'Remove' are present.
- ROOM DETAILS:** Input fields for Wet Deck Area (ft²) (3500), Pool Room Volume (ft³) (45000), and Number of Spectators (0).
- AIR CONDITIONS:** Input fields for Room Design Temperature (°F) (84), RH Design Unoccupied (%) (50), and RH Design Occupied (%) (60).
- Unit Design:** Input fields for Number of Units (1), Pool Water Heating (°F) (Yes/No), Refrigerant Type (R407C/R410A), and Outside Air Required (Yes/No).
- Outdoor Air Design:** Input fields for Outside Air Design CFM (2700, with a note '(2700CFM Recommended)'), Country (Canada), State/Province (Ontario), and City (TORONTO LESTER B. PEARSON INT).
- Summary Table:** A table at the bottom with columns for Elevation (ft), Summer db (°F), Summer wb (°F), and Winter db (°F). Values are: 568, 88.1, 72.0, 3.0.

Humidity Control Technology

How to Remove Moisture

Engineers typically consider one of three approaches to ventilate a natatorium. It is important to understand the capabilities and limitations of each approach in order to select the best system for the application. Seresco manufactures all three styles of unit and will help you evaluate what is right for your application. Energy consumption, geographic location, budget and desired control of space conditions are among some of the key decision making criteria.

- Refrigeration based dehumidifiers
- Chilled water with reheat air handler
- Outdoor air ventilation (usually with heat recovery)

Refrigeration Based Dehumidifiers

Refrigeration based dehumidifiers are by far the most common and popular method of removing moisture from the space. These are the NE Series style unit built by Seresco. The units are designed and developed specifically for dehumidifying indoor pools. They offer year round humidity control at the lowest operating costs.

A major benefit of this approach is year round humidity control with low operating costs. These systems use both sides of the refrigeration cycle (evaporator and condenser) simultaneously. Contrast this to traditional air conditioning units that use only the evaporator and dump condenser heat outdoors. These units use the evaporator to dehumidify (and cool when needed) but also put heat back into the pool and/or back into the process air. This approach is unique to the

The Energy Cycle

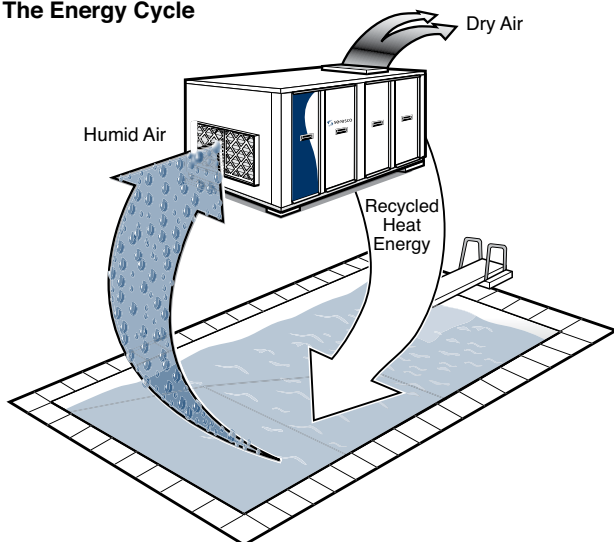

natatorium industry. The system can be simultaneously dehumidifying (cooling) the air and then reheating it (and/or the pool water) to deliver dehumidified and reheated air to the space, and warm water to the pool. Not a single BTU on either side of the refrigeration cycle is wasted. COPs are close to 8 and EERs greater than 25!

Figures 3 and 4 illustrate schematically how warm humid air passes through the dehumidifying coil and is cooled to below its dew point. Once air is cooled below its dew point, moisture condenses out of the air. Depending on the space temperature requirements the hot gas from the compressor can be used to reheat the air or be rejected to an outdoor condenser. Compressor hot gas can also be used to heat the pool water. Figure 4 shows an example of these components in a vertical unit.

Figure 3 – Packaged Mechanical Refrigeration Systems

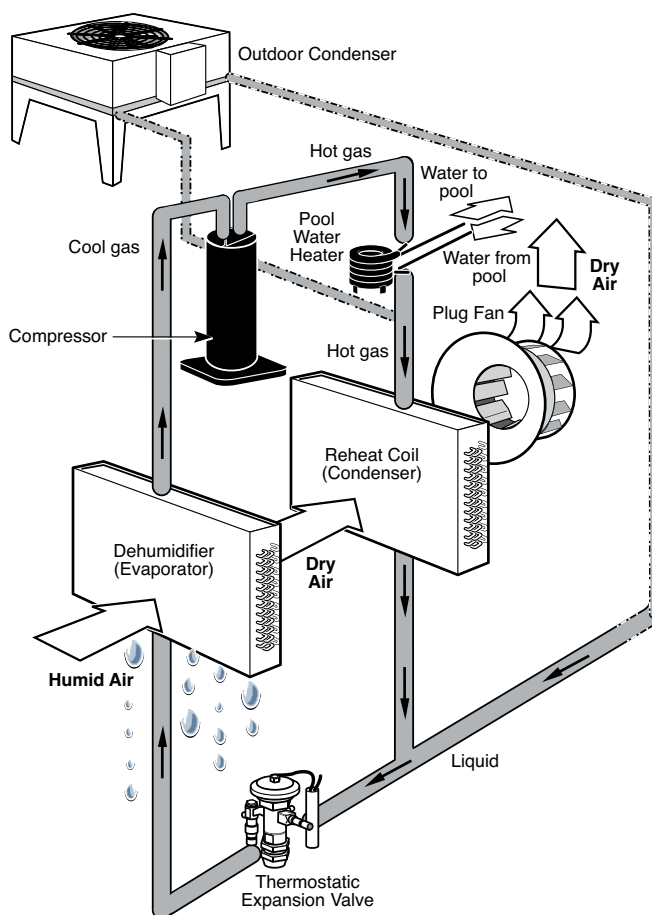
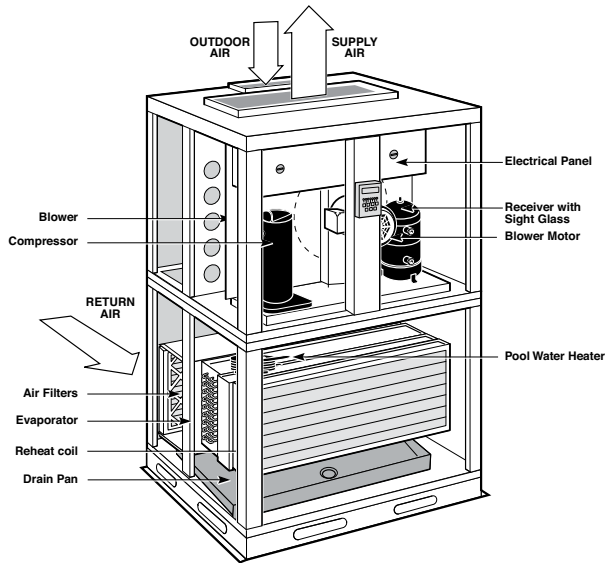

Figure 4 – Vertical Dehumidifier



Chilled Water with Reheat Air Handler

These units are not very common and generally only found on applications that have abundant chilled water year round and installing a refrigerant based system proves problematic. The dehumidification process of these systems is essentially the same as with compressorized systems. The chilled water supply temperature must be low enough to cool the air below its dew point at the chilled water coil and condense moisture out of the air. Reheat is required for most of the year. Systems that cannot use captured condenser heat for reheating air require the operation of a heating coil while the chilled water coil is in use. If reclaimed heat is not available for reheat, this approach does not meet most energy codes. This approach is not recommended if chilled water is not available year round.

Outdoor Air Ventilation Systems

While not technically a dehumidifier, because only outdoor air is used, this approach is considered in areas that are dry and/or cool outdoors year round. Solutions can be a very basic, from a single pass of outdoor air that is introduced at one end of the space and exhausted at the other to a more sophisticated system that has variable outdoor air and heat recovery. The single pass system is rare due to the prohibitive operating costs.

A more typical approach is the Seresco NV series style ventilation unit. These units provide ventilation air, heat recovery, heating and also

have 100% outdoor air modes for milder weather. It is important to note that the space conditions may not be maintained in summer as the outdoor air may not be dry enough.

The outdoor ventilation style units have several attractive features if your facility is located in a suitable geographic area. They have a lower first cost than a refrigerant based approach and are also considerably simpler units. With heat recovery between the exhaust air and outdoor air streams and controls that properly sequence the outdoor air, this can be a very attractive means to ventilate a natatorium.

There is a misconception that because these systems provide more outdoor air than a refrigeration based unit that the spaces as a result will have much better air quality. This is not correct. The airside design requirements are the same for a Natatorium regardless of which solution is chosen. Supply air CFM, minimum outdoor air CFM and minimum exhaust air CFM requirements are identical for all systems.

Some manufacturers promote more outdoor air than codes require in order to ensure good IAQ. Seresco does not recommend this approach because it increases building operating costs and still may not have any such impact on the space if the air distribution is not done correctly. A better solution is to stick with the ASHRAE guidelines and ensure the air distribution is correct.

System comparisons and features are highlighted in table 4. Note: The table assumes all units are designed with the same airside characteristics.

Table 4 – System Comparison

	Refrigeration	Chilled Water	Outdoor Air Ventilation
Operating Cost	Lowest	Highest	Medium
First Cost	Highest	Medium	Lowest
Year round humidity control	Yes	Yes	Weather dependant
Meets/exceeds Energy Standard 90.1	Yes	No	No
Dehumidification energy recovery	Yes	No	No
Heat recovery on Exhaust and Outdoor air	Option	Option	Option
Free summertime AC	Yes	Yes	No
Free summertime pool water heating	Yes	No	No

Indoor Air Quality

Good indoor air quality can be a challenge in an indoor pool. However, designers that follow ASHRAE guidelines as well as those addressed in this manual should have every expectation of a great space condition and pleasant overall experience for the patrons of the facility. There are steps a design engineer must take in their design to minimize the chances that a patron experiences a foul smelling pool odor and stinging eyes. There are many factors that impact the IAQ in a natatorium: pool water chemistry problems, inadequate outdoor air, air stagnation, poor air distribution, high humidity, mold, mildew, condensation and corrosion.

Four of the five key factors having the most direct impact on Indoor Air Quality (IAQ) are under the control of the design engineer.

- Pool water chemistry
- Poor air distribution: No Airflow in the Breathing Zone.
- Outdoor air ventilation
- Exhaust air
- Air change rate

Chemical off gassing from the pool water is the pollutant that causes all the IAQ issues in a natatorium. A successful HVAC design will adequately remove these chemicals and provide good IAQ by properly addressing the four key airside design requirements.

Pool Water Chemistry

Pool Water Chemistry is the key variable that impacts IAQ and is not under the responsibility of the design engineer.

Good pool water chemistry by the building operator is critical in order to achieve levels of human comfort and health. Also by maintaining optimal pool water conditions you will have the best possible indoor air quality and ensure optimal performance from the mechanical system.

Poor water chemistry is the single biggest source of indoor air pollution and corrosion problems in a Natatorium.

Ultraviolet light (UV) treatment of pool water has shown to have a very positive

impact on the water chemistry and can help reduce, if not totally eliminate chloramines. This approach to enhance water treatment is gaining popularity and as positive data continues to come should become more and more common.

Chlorine smell

When you walk into an indoor pool and smell a strong chlorine odor, you naturally think it's caused by too much chlorine in the water. The odor is actually caused by chloramines (combined chlorines) off gassing from the pool water surface. Chloramines are formed in the pool water when there is insufficient free chlorine in the pool to address the nitrogen-containing compounds brought into the pool water by the swimmers. These nitrogen compounds are naturally-occurring and contained in sweat, urine, body oils and other proteins that get released into the pool water. If the introduction of these nitrogen compounds outpaces the introduction of free chlorine the chlorine becomes combined with the nitrogen compounds rather than fully oxidizing them. The chloramine (combined chlorine) levels increase in the water, resulting in an increase in chloramine off-gassing, which creates the odor of chlorine in the room. There are three different types of chloramines that can form: monochloramine, dichloramine and trichloramine. Trichloramine is the most volatile and will off-gas most quickly.

The powerful chlorine smell that is often associated with indoor pools is NOT the result of too much free chlorine in the water; it is TOO LITTLE free chlorine that is the culprit!

To avoid chloramines it is imperative to maintain proper free chlorine and pH levels as outlined in table 5.

Table 5 – National Spa and Pool Institute Recommended Levels for Water Quality

Pool Water Chemistry Parameters Recommended by NSPI		
	Pools	Whirlpools
	Desirable Range	Desirable Range
pH	7.4 – 7.6	7.4 – 7.6
Alkalinity	80 – 100 PPM	80 – 100 PPM
Free Chlorine	2.0 – 3.0 PPM	3.0 – 4.0 PPM
Combined Chlorine	0 PPM	0 PPM
Dissolved Solids	100 – 300 PPM	100 – 300 PPM
Total Hardness	225 – 250 PPM	175 – 275 PPM

Off-gassed chloramines also have a strong attraction to the airborne humidity which will combine with moisture in the air. Consequently, any condensation of the space humidity will become corrosive. An example of this can sometimes be seen at pools with chloramines problems where the ladder rails outside the water corrode while the portion under water does not.

The proper balance of outdoor air and room exhaust air along with air movement at the water surface is also crucial to ensuring chemical concentration levels are maintained within acceptable levels.

Pool Water pH Levels

High pH levels (alkaline range) encourage scale formation, which reduces pool water heater efficiency. With low pH levels the water is acidic and corrosive. This may damage the metal parts in pumps, water heaters and piping. Maintaining pH levels between 7.2 and 7.6 will ensure the longest life for the pool equipment.

Total Dissolved Solids

It is imperative that pool water filters are routinely back washed and that total dissolved solids monitored. High quantities of total dissolved solids will overrun the free chlorine levels and form chloramines.

A proper pool water test kit should monitor the parameters seen in table 5.

Humidity and Corrosion

As previously mentioned, off-gassed chloramines have a strong attraction to the airborne humidity and will combine with moisture in the air. Consequently any condensation of the space humidity will become corrosive. It is critical that the space humidity levels be controlled such that condensation is prevented as it will damage the building and mechanical system. Seresco units are built for a pool environment. All electrical and refrigeration components are out of the pool air and in a protective service vestibule. The components in contact with the pool air stream are protected with the best possible corrosion resistant paints, coatings and materials. Seresco units are built to last!

By design, indoor pool environments are warmer and have higher moisture levels compared to traditional spaces.

Engineers and architects must understand the consequences of this and pay special attention to the special requirements on the entire HVAC system and building envelope.

Outdoor Ventilation Air

The amount of outdoor air to be introduced to the facility is determined by construction codes. Most codes adopt ASHRAE Standard 62. Outdoor air is critical towards diluting airborne chemicals and maintaining good indoor air quality.

Facilities that introduce outdoor air per ASHRAE Standard 62 and have proper air distribution have the best IAQ.

- More outdoor air than required by ASHRAE Standard 62 is not recommended (except water parks)
- Outdoor air requires a significant amount of heating energy in the winter and must be included in heat load calculations.
- Heat recovery should be considered between the exhaust air and outdoor air streams.
- Exceeding code amounts is not recommended, as it creates extremely high operating expenses. Engineers must ensure condensation is avoided. Wintertime outdoor air is cold and in summer it can be very humid. Both scenarios can lead to condensation.
- Introduce the outdoor air at the factory provided intakes on the air handlers
- Locate outdoor air intakes away from sources of airborne contamination such as exhaust fans or plumbing vents.
- The outdoor air must be preheated to 65°F – If more than 20% of the total airflow is outdoor air or if the winter design temperature is below 10°F
- A certified air-balancing contractor must balance the system airflow.

All Seresco units are equipped with an outdoor air connection, filter and balancing damper. Motorized dampers and time clocks are also available.

Exhaust Air

ASHRAE recommends the room be maintained at 0.05-0.15" WC negative pressure relative to surrounding spaces.

Ten percent more exhaust air than outdoor air is a good rule of thumb.

More exhaust air than recommended by ASHRAE will not reduce or stop moisture migration through the building envelope to outdoors in cold weather. Vapor migrates based on vapor pressure differential. There is effectively a 10" WC pressure differential between indoors and outdoors on cold winter days. There is no amount of negative airside pressure you can put into a space to stop vapor migration. The building envelope

must be designed by the architect to adequately deal with this by placing vapor retarders in appropriate locations in the entire building envelope.

Figure 5 illustrates how the strategic location of the exhaust grille can also significantly improve the air quality in the space. A spa or whirlpool should have the exhaust air intake grille located directly above it. This source captures and extracts the highest concentration of pollutants before they can diffuse into the space and negatively impact the room air quality.

Air Change Rate

ASHRAE recommendations for proper volumetric supply air changes per hour are important, ensuring that the entire room will see air movement. Stagnant areas must be avoided, as they will be prone to condensation and air quality problems.

Short circuiting between supply and return air must also be avoided as it significantly reduces the actual air changes within the space.

ASHRAE recommends:

- 4-6 volumetric air changes per hour in a regular natatorium

Figure 5 – Exhaust Air

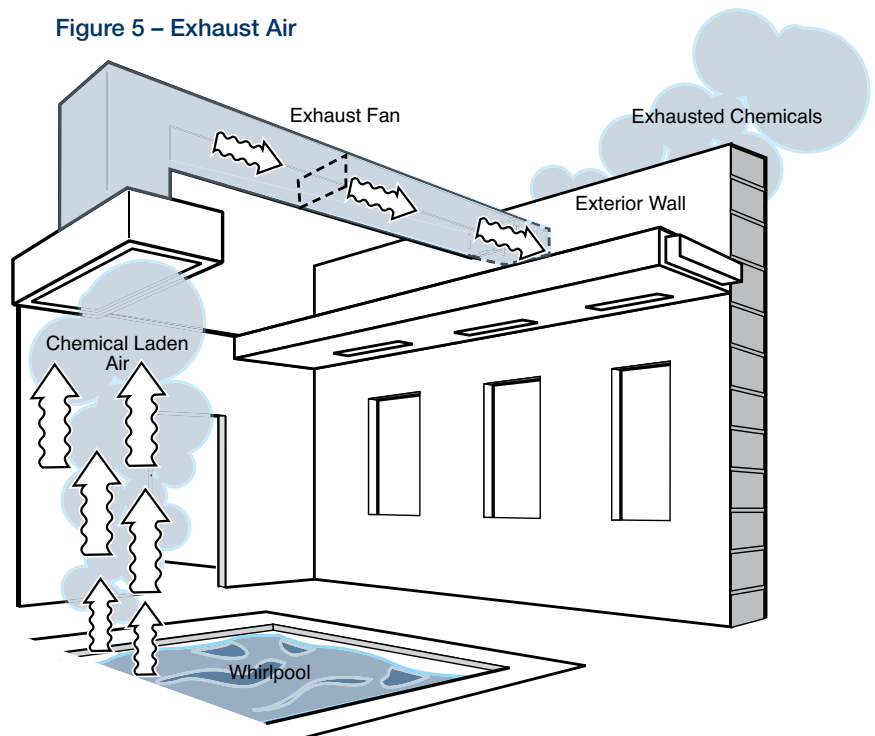

- 6-8 volumetric air changes per hour in facilities with spectators

A quick calculation will determine the supply air requirement.

- Supply air required (CFM) = room volume (ft³) x desired air changes / 60

Condensation Control

You only have to enjoy a cold drink on a summer day to experience dew point and condensation firsthand. Condensation occurs because the surface temperature on your glass is below the ambient dew point temperature. While 50-60% relative humidity levels are ideal for bather comfort and health they much higher than people than what people are used to seeing in traditional spaces in winter. In northern climates it is very common to humidify in order to get the humidity levels up to 30-40%. An indoor pool and humidified space can experience condensation problems and serious damage to the building structure in cold weather if they are not designed properly.

Condensation is a major concern for all types of building construction. Condensation triggers a destruction process and allows mold and mildew to grow. If allowed to occur inside the building walls or roof, condensation will cause deterioration and can devastate the structure by freezing in winter.

As previously mentioned, off-gassed chloramines have a strong attraction to the airborne humidity and will combine with moisture in the air. Consequently any condensation in a pool, in addition to being destructive on its own, could also be corrosive. It is critical that condensation be avoided at all costs.

The building design and construction must appropriate to house an indoor pool. The envelope design and construction must be suitable for 50% to 60% relative humidity year round.



A successful design will identify and blanket building elements low R-values (typically exterior windows) with warm supply air to prevent condensation. Window frames and emergency exit doors must also be thermally broken to avoid condensation.

Dew Point Temperature

The first step in condensation control is to establish the space dew point temperature based on the owners desired space conditions. With that the designer can establish potential condensation spots in the building.

Figure 6 – Dew Point Temperature

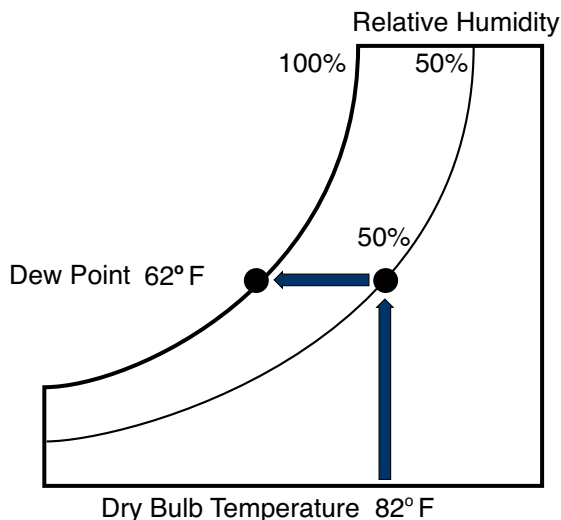

A pool's indoor design dew point will typically range from 62-69°F (82-84°F 50-60%RH). Contrast this to a typical space in winter that might be 70°F 40%RH which has a 45°F dew point.

Pools have a much higher likelihood of condensation because of both an elevated space temperature and slightly higher relative humidity adding up to a very high dew point.

These are building elements with low R-values that will have an inside surface temperature below the dew point at winter design condition. Most importantly, the dew point also establishes where to locate the vapor retarder in the wall. Figure 6 shows that a typical pool design of 82°F 50% RH has a dew point of 62°F. Therefore, any surface with a temperature below 62°F will condense moisture.

Vapor Retarder

A vapor retarder is a material that restricts the rate of water vapor diffusion through the ceilings and walls of a building when below dew point temperature occurs. Figure 7 illustrates how failure to install the vapor retarder in the proper location will result in condensation within the structure. Condensation in your walls or roof can lead to structural failure. A vapor retarder should be sealed at all seams.

Figure 7 – Do Not Build an Indoor Pool without a Vapor Retarder

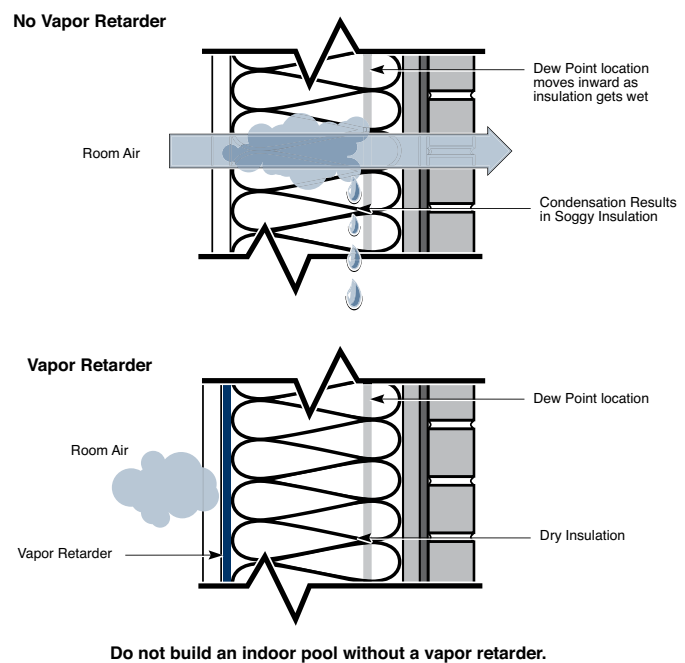

Ensure the entire pool enclosure design (walls and ceilings) has a vapor retarder in the correct location. Care must be taken where walls and roof and walls and floor meet to ensure there is no breach in the vapor barrier.

A properly located and installed vapor retarder is the only means of protecting a building structure from vapor migration that becomes moisture damage.

Figure 8 is an example of a wall detail with its temperature gradient. This exercise allows the designer to identify the dew point temperature in the wall and where the vapor retarder must be installed.

Window Design

Windows have a relatively low R-value and as a result will have surface temperatures below the pool room dew point when it gets cool outside. Exterior windows will develop condensation on the first cold day unless measures are taken. The solution to the condensation problem is to fully blanket every part of the window with supply air from the HVAC system. It is critical that no section be missed or it will get cold and condense.

Figure 8 – Pools are different – install the Vapor Retarder on the Warm Side of the Dew Point

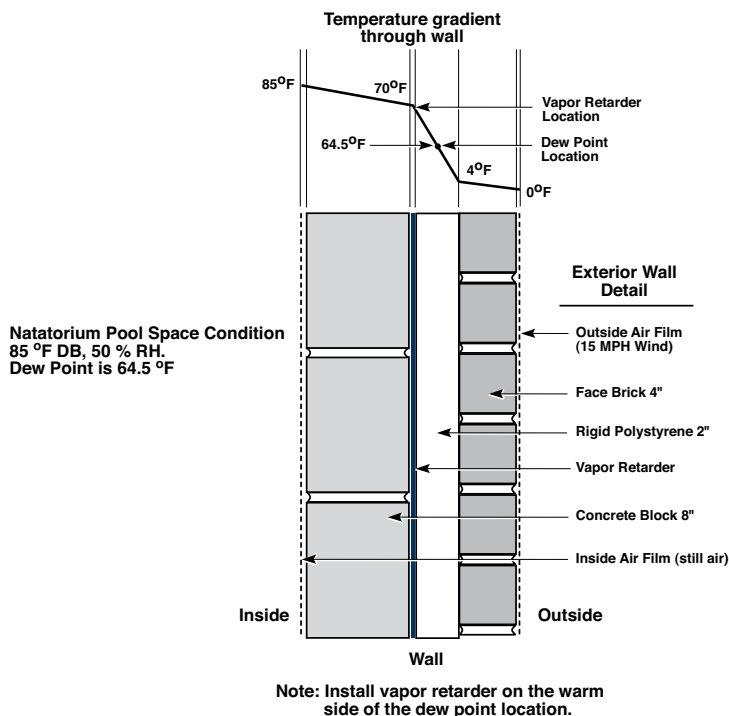
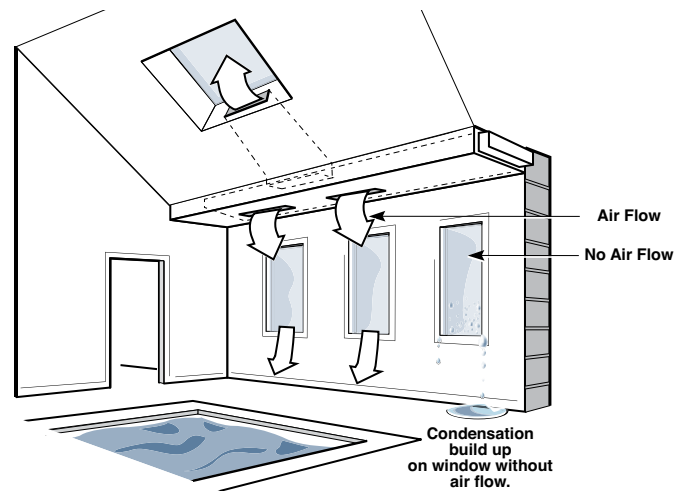

Figure 9 – Window Design



The solution exterior window condensation is simple: fully blanket them with supply air from the HVAC system.

Air Distribution

Since exterior windows and exterior doors are a primary condensation concern it is extremely important that the supply air is focused there. The warm air from the dehumidifier will keep the window surface temperature above the dew point temperature and this in turn ensures the windows and exterior doors remain condensation free.

There are five basic steps to laying out the ductwork:

1. Supply air to exterior windows and doors.
2. Supply air to the breathing zone at the deck level and water surface.
3. Supply air to the remainder of the room to ensuring there are no stagnant areas
4. Locate the return duct where it will optimize the entire airflow pattern.
5. Prevent air short-circuiting by avoiding supply air diffusers near the return grille.

The following sample duct diagrams illustrate good air distribution practices:

All air distribution systems should:

- Satisfy ASHRAE design requirements and local codes.
- Supply at least 4-6 volumetric air changes per hour.
- Blanket exterior windows, exterior surfaces and other areas prone to condensation with supply air. A good rule of thumb is 3-5 CFM per ft² of exterior glass.
- Locate the return grille to enhance the overall air pattern within the room.
- Select grilles, registers and diffusers that deliver the required throw distance, and the specified CFM rating.
- Introduced outdoor air per local codes and/or ASHRAE Standard 62-2004.
- Maintain a negative pressure in the space with an exhaust fan.

Figure 10 – Perimeter Duct Layout

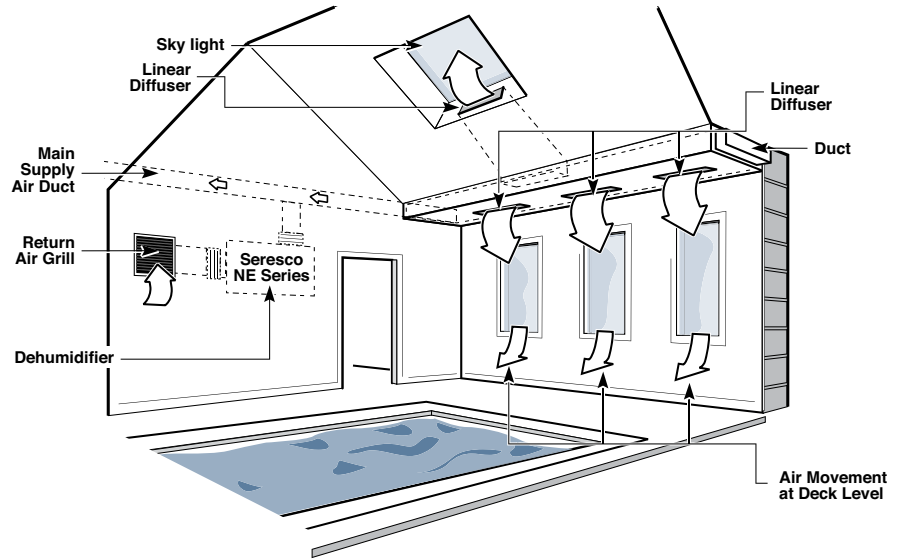
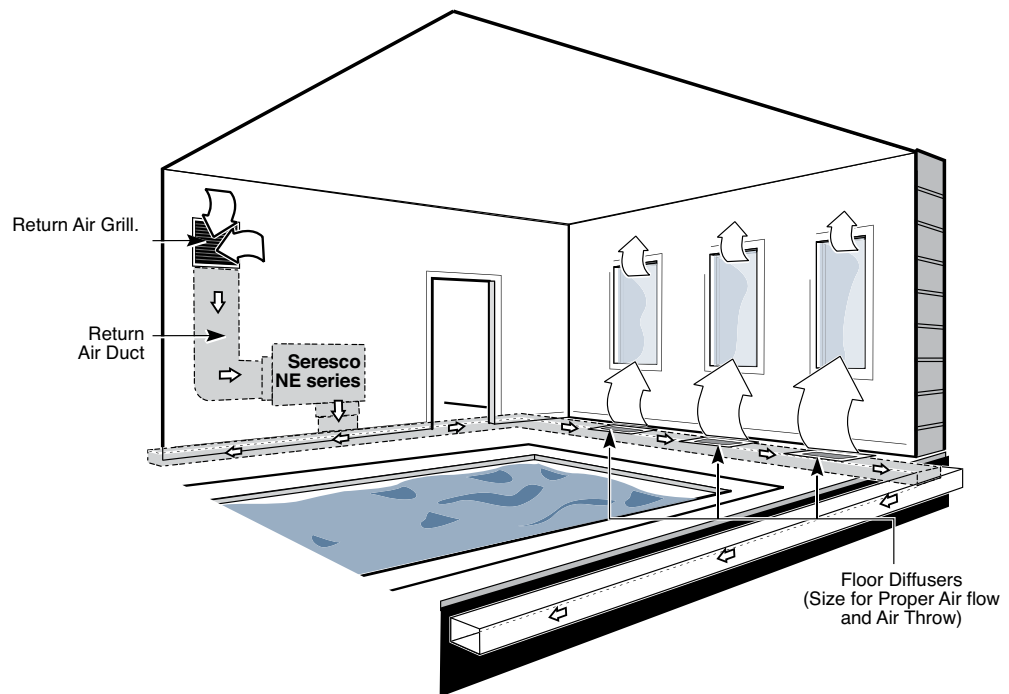

Figure 11 – Perimeter Below-Grade Duct Layout

General Recommendations:

- Galvanized sheet metal ducts are acceptable in most installations. A below-grade duct system should use PVC or plastic-coated galvanized spiral pipe to avoid deterioration.
- Fabric duct is an excellent choice of duct material for a Natatorium. The duct material should not allow air to leak. The location of supply grilles and overall duct layout should be exactly as you would with metal duct.
- Ductwork that passes through an unconditioned area should be insulated on the exterior.
- When applicable, locate exhaust fan air intakes as close to the whirlpool as possible.
- To prevent excessive vibration noise, install neoprene flex connectors when attaching ductwork to the dehumidifier. Acoustic insulation on the duct close to the unit may also be a consideration.
- Skylights require significant airflow to avoid condensation on their surfaces.



Energy Consumption Considerations

Energy consumption and performance implications based on the owner's choice of operating conditions and building envelope should be discussed in order to ensure there are no surprises. An all glass structure, for example, is going to be expensive to heat and difficult to keep condensation free in a northern climate.

A natatorium has 5 major areas of energy consumption:

- Pool water heating
- Dehumidification
- Space heating in winter
- Space Cooling in summer
- Outdoor air heating and cooling

Operating Conditions

Pool water heating and evaporation rates are always interrelated. Every pound of moisture evaporated to the space is a load to be dehumidified and it also represents heat lost by the pool water. 90% of a pool's annual water heating cost is due to pool water evaporation losses. Every pound of moisture evaporated represents ~1000 Btu of heat lost from the pool water body and unless a pool is covered, they lose that heat (evaporate moisture) 24/7.

- The warmer the pool water, the higher the evaporation rate.
- The lower the space relative humidity level, the higher the evaporation rate.
- The lower the room temperature (dew point), the higher the evaporation rate.

At the same water temperature a pool in a room at 78°F 50% RH will evaporate almost 35% more than that same pool in an 85°F 50% RH room.

While the space temperature should be dictated by the owner based on what satisfies their patrons, is it useful to be aware of a few guidelines that can help with energy consumption:

- Maintaining the room air temperature 2°F-4°F above the pool water temperature (86 degree maximum, per ASHRAE) will help reduce evaporation. This reduced evaporation in turn reduces the pool water heating requirement.
- Do not introduce more outdoor ventilation air than required by code. In winter the space relative humidity levels will drop below 50% which increases the evaporation and pool water heating.

Pool Water Heating Energy Recovery

When using a refrigeration based approach to control humidity, the dehumidification process captures energy in the refrigerant at the evaporator coil. The latent heat component is essentially the pool's evaporation. Evaporation represents a significant portion of the pool's annual water heating requirements. If this energy is captured in the refrigerant, why not return it back to the pool water where it came from? This is free heat as a byproduct of dehumidifying the air. A Seresco dehumidifier with the pool water heating option has an enormous potential for energy savings.

A Seresco dehumidifier with the pool water heating option will capture and return the energy the pool water lost through evaporation. **This process has an impressive COP of close to 8!**

The use of the pool water heating option satisfies ASHRAE Energy Standard 90.1, otherwise a pool cover is required to meet the standard.

The Energy Cycle

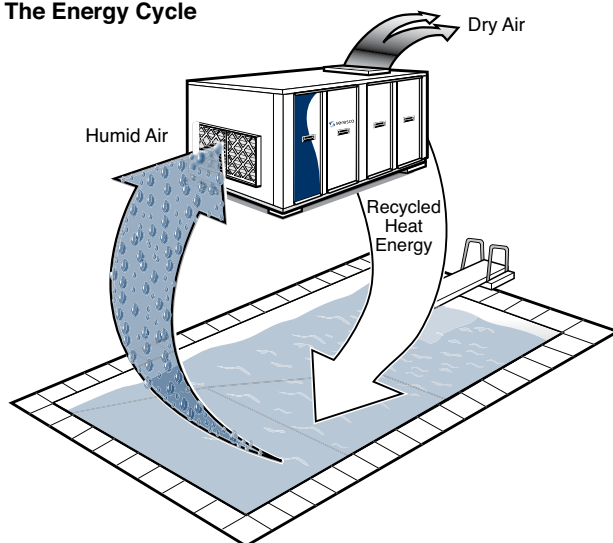

The Seresco refrigeration based unit uses 100% of the compressor hot gas to heat the pool water and/or reheat the air. Returning this free energy back to the pool water or room air greatly reduces the annual heating costs. During the cooling season the dehumidifier is capable of providing 100% of the pool's water-heating requirement.

The mechanical refrigeration system approach to controlling the environment in a pool is a unique use of the refrigeration system. The evaporator controls the humidity while simultaneously the compressor hot gas can be used to heat the pool water and/or room air. Traditional air conditioning systems merely send the compressor hot gas outdoors to a condenser or cooling tower and do not tap into this heat source.

Adding the pool water heating option to your dehumidifier typically has a payback of less than one year.

Table 6 shows the annual contribution towards water heating from the dehumidifier while operating in cooling mode. A pool with a 50 lb/h evaporation rate and cooling season of 2000 hours would realize an annual savings of \$2,350 if the primary source of pool water heating was an electric heater.

Calculations based on: 1000 Btu/lb latent heat of vaporization. Gas: \$0.60 per 100,000 Btu, efficiency = 75%. Electricity: 8¢ per kWh

All systems require auxiliary pool water heaters. The Seresco unit will control their operation when it is not able to provide full water heating.

Space Heating

As with every other room being designed, the cooling and heating load calculations should be done for the natatorium. That is the only way to ensure the specific heating and cooling requirements are met. The room air temperature of an indoor pool facility is generally 10-15 °F warmer than a typical occupied space so the heating requirement per square foot of a natatorium will be considerably higher than a traditional room.

- Outdoor air must be included in load calculations as it often represents up to 50% of the heating load.

Space Cooling

Most patrons prefer buildings with year round temperature control. Even though the space is generally 10-15 °F warmer than a typical room, most patrons would find it objectionable to be in a space that has no cooling at all.

Space cooling is a free byproduct from packaged dehumidifiers and chilled water systems. Providing year round temperature and humidity control can be provided by these systems. These systems dehumidify by cooling the air below its dew point and condensing moisture at the cooling coil. If the cooling load exceeds the standard output of a dehumidification unit, a larger unit with compressor staging is often specified.

Packaged Refrigeration or Chilled Water dehumidifiers provide summertime space comfort with no additional operating cost to the owner.

Outdoor Air, Exhaust Air and Energy Recovery

Outdoor ventilation air is essential for maintaining good IAQ in the pool and is a code requirement. The natatorium needs to be maintained at a slight negative air pressure, so warm “energy rich” air needs to be exhausted.

Outdoor air must be conditioned. It must be cooled and dehumidified in the summer and heated in the winter. In northern regions outdoor air has the biggest impact in winter where it reduces the space relative humidity levels and represents a significant portion of the natatorium’s heating requirement. In southern regions the outdoor

Table 6 – Annual Water Heating Savings from Pool Heating Option

Annual Savings from Pool Water Heating Option									
Cooling Season	Heat Source	Average Pool Evaporation (lb/h)							
		20	30	40	50	100	150	200	300
4000 hours	Gas	\$640	\$960	\$1280	\$1600	\$3200	\$4800	\$6400	\$9600
	Electricity	\$1880	\$2820	\$3760	\$4700	\$9400	\$14100	\$18800	\$28200
2000 hours	Gas	\$320	\$480	\$640	\$800	\$1600	\$2400	\$3200	\$4800
	Electricity	\$940	\$1410	\$1880	\$2350	\$4700	\$7050	\$9400	\$14100

Figure 12 – Heat Exchanger

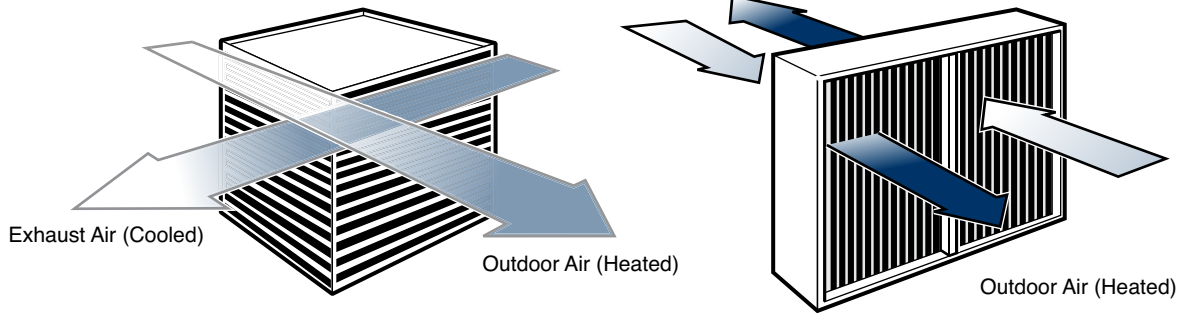

air introduces a lot of moisture and increases the dehumidification load.

In northern regions outdoor air in winter may need to be heated 100°F just to get neutral to the space temperature in the pool!

The designer has several energy issues to consider:

- Introducing more outdoor air than codes is not recommended:
 - In winter it will increase space heating and pool water heating costs significantly.
 - Too much outdoor air in winter can also lower the relative humidity levels to uncomfortable levels for the patrons. Yes, the pool room can actually be too dry!
 - In summer it can introduce so much additional moisture that larger equipment could be needed.
- Warm “energy rich” air is required to be exhausted from the space to maintain negative pressure and good IAQ.

Energy recovery from the “energy rich” exhaust air to outdoor air should be considered.

Air-to-air heat exchangers are available for both sensible heat recovery and total energy recovery. Sensible only devices are used in Natatoriums. All sensible recovery devices are effective but some are better suited to provide a cost effective solution. Figure 12 shows two examples. There are several considerations to determining the need and feasibility of heat recovery:

- Is the installation in a northern application?
- Does the outdoor ventilation air need to be conditioned in order to avoid condensation when blended with the room air in summer and winter?
- Are the outdoor ventilation air and exhaust air streams within close proximity to each other?
- What is the payback on this investment?

Heat recovery is generally packaged as part of a dehumidifier when outdoor or rooftop installations are specified. Figure 13 shows a schematic of the preferred heat recovery method used by Seresco. The heat recovery devices in Figure 12 require special and complicated air paths within the unit. This increases the unit size and cost and also has a large airside pressure drop which increase blower motor sizes and operating costs. Seresco has chosen a better solution and opted for a heat recovery option that can be packaged seamlessly within the standard dehumidifier or can be remotely installed in the ductwork.

Seresco provides unit mounted heat recovery using a glycol run-around loop. This approach to heat recovery offers the best performance and design flexibility while staying in the smallest possible cabinet. This heat recovery coil set fits directly onto the outdoor air and exhaust air openings already provided on the unit and does not increase the cabinet size. They are also easily sized to meet the specific requirements of your facility. The result is a compact, cost effective heat recovery option that actually fits into a mechanical room. The

Figure 13 – Packaged Heat Recovery

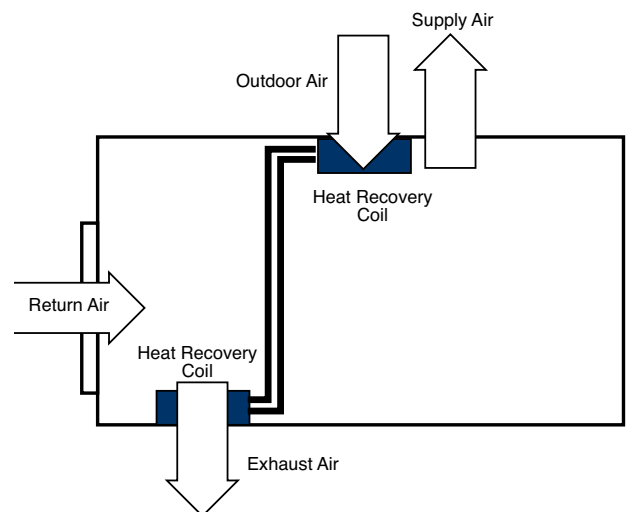

compact nature if this design results in lighter weight cabinets compared to units integrating plate heat recovery technology. This is an important consideration on applications where roof loads are a concern.

The glycol run around loop performance is engineered for a pool application. The coils are fully dipped for corrosion protection and there is no defrost or bypass mode on the coldest winter days. When you need the heat recovery the most, other heat recovery devices require that you bypass air to keep them from freezing up.

The introduction of the heat recovery coils into the existing air streams offers a substantially lower overall airside pressure drop compared to units with dual air paths and complicated internal air patterns. This configuration offers the end user the lowest possible operating cost while providing the best possible heat recovery effectiveness.

Adding the heat recovery option to your Seresco unit in a northern installation will typically realize a one year payback on your investment!

Seresco has developed a quick calculation to help determine the energy recovered and energy savings possible from the heat recovery coils.

Pool rooms are warm – It is surprising to note that heat recovery is viable even in a mild climate like Atlanta.

The savings are noteworthy even in a mild climate. The added cost of a heat recovery device generally pays itself back in less than two to three years in a mild climate.

Table 8 – Energy Recovery Calculation

Weather Data		
City	Average ° F T1	Winter °F T2
Atlanta	61	17
Boston	51	6
Buffalo	43	2
Chicago	51	-8
Dallas	65	18
Denver	50	-5
Detroit	49	3
Minneapolis	45	-16
Indianapolis	52	-2
Nashville	60	9
New York	54	11
Oklahoma City	60	9
Pittsburgh	50	3
Portland, OR	53	17
Salt Lake City	52	3
Seattle	51	20
St-Louis	55	2
Toronto	46	-5

Heat Recovery Savings (Q) Analysis			
	Pool Location	Atlanta	
T1	Average Outdoor Temperature	61	°F
T2	Winter Design Temperature	17	°F
T3	Indoor Design Temperature	84	°F
V	Outdoor Air Volume	3500	CFM
N	Occupied hours	12	Hours
ER	Electric Rate:	0.06	\$/kW
GR	Gas Rate:	0.65	\$/CCF
GE	Gas Heating system efficiency:	60	%
	Space Heating by:	GAS	
HE	Heat Recovery Efficiency	50	%
Q	$\{T3-T1\} \times 1.08 \times V \times \{8760 \times N / 24\} \times GE$	190400	MBH
Annual savings from heat recovery device			
\$	$\{Q \times \$/CCF\} / HE$	\$2,062	
Reduction in peak heating			
Q1	$\{T3-T2\} \times 1.08 \times V \times HE$	126,600	Btu/h

Finalizing System Design

At the core of every successful natatorium design is a system that provides the operator the year round conditions they expected while meeting ASHRAE design standards, satisfying local codes and being as energy efficient as possible.

This design guide has covered many important aspects to consider and putting it all together properly can become a daunting task. The Seresco team has worked on thousands of indoor pools and developed a helpful checklist to help ensure all vital aspects are considered during the design process. Seresco understands also that product flexibility is essential to allow the designer to work around all the project-specific issues while not compromising their design, and offers the most flexible product line in the industry. The overall performance of a Natatorium will be directly impacted by the number of deviations and compromises taken in its design.

Once all the design parameters have been established, the only remaining decisions will be: what would they like incorporated into their Seresco dehumidifier and what they want provided externally. Unit mounted heating coils, exhaust fans, heat recovery packages, weatherproof outdoor cabinets and heat rejection to cooling towers/dry-coolers/outdoor condensers are some of the configurations available from Seresco. The project specific details generally dictate what is the most appropriate.

Key Design Concerns for Traditional* Pools

The back cover of this manual is a handy checklist that covers the Key Design Considerations.

* Please contact factory for Waterparks and pools heavy with water features. Design standards have been established for 'traditional' bodies of water and do not adequately address the special needs of these facilities.

Step 1: Operating Conditions

Do not guess. Get the desired pool water temperature, room temperature and relative humidity in writing from the owner.

Operating conditions have a tremendous impact on the entire design and cannot be changed by a large degree after the fact. It is critical that the designer educate the customer on the implications of their operating temperature choices. Maintaining the room air

temperature 2°F-4°F above the pool water temperature will help reduce evaporation – but the temperature must still be comfortable to the patrons. Reduced evaporation in turn reduces the pool water heating requirement.

Step 2: Supply Air

Calculate the supply air requirement of the space based on the room volume. Your target air change rate per ASHRAE is 4-6 volumetric air changes per hour, with a 6-8 air change rate in spectator areas. This is a calculation and sets up the entire air handling systems.

- Supply air must get down into the **Breathing Zone**. It is critical for comfort and good IAQ that the treated supply air get down to the pool deck and occupants.
- Ensure the **return duct location** compliments the supply air duct location and promotes a good air pattern. In a large natatorium, several return air grilles might be required to achieve a good air pattern in the space.
- Be careful to avoid air short circuiting or placing supply diffusers too close to the return duct opening. This can ruin the effectiveness of the supply air and give any return duct mounted sensors false readings.

Step 3: Outdoor Ventilation Air per Standard 62-2004

Most localities have adopted Standard 62 as their local code. The baseline outdoor ventilation air requirement is:

- 0.48 CFM/ft² of water surface area and wet deck for regular pool. Wet Deck is a maximum 6-8 foot perimeter around the pool.
- If you have a spectators seating area, add 7.5 CFM per spectator during swim meets.

Introducing more outdoor air than codes is not recommended. In winter it will increase space heating and pool water heating costs significantly. Too much outdoor air in winter can also lower the relative humidity levels to uncomfortable levels for the patrons.

- Outdoor air must be filtered.
- Ensure the airflow is balanced when the system is commissioned.
- Preheat the outdoor air to 65°F to avoid condensation problems. Seresco's glycol heat recovery loop is a good means to accomplish this while also saving the operator in heating costs.
- Thermally insulate the exterior of the outside air duct.

Step 4: Exhaust Air

The room should have a slight negative pressure. ASHRAE recommends 0.05 to 0.15 inches of water column. A good rule of thumb is to exhaust 110% of the outdoor air CFM. A well located exhaust fan can significantly improve the air quality in the space. If the space has a spa or whirlpool, the exhaust air intake grille should be located directly above it. This source captures and extracts the most contaminant-laden air before it can diffuse into the space and negatively impact the room air quality.

- The exhaust fan can be installed remotely or within the Seresco unit.
- Energy recovery from the energy rich exhaust air to outdoor air should be considered.

Step 5: Load Calculations

The Natatorium needs to be heated, cooled and dehumidified. Accurate calculations need to be carried out to establish the requirements to accomplish each.

- Latent load (Pool evaporation, Outdoor Air (summer) and Spectators)
- Building envelope sensible cooling load that includes Outdoor Air.
- Building envelope heating load that includes Outdoor Air.

A majority of designers prefer to place the space heating coil inside the dehumidifier. The coils in a Seresco unit are fully coated and suitable for a pool environment. Seresco offers a full range of unit mounted control valves as well.

Care must be taken when considering gas heating. If chlorine from the natatorium is allowed to mix with combustion gases, hydrochloric acid (HCl) forms and is very corrosive. All Seresco's gas heat options have been engineered so that they are fully protected from this ever happening.

Step 6: Condensation and Vapor Migration

Establish the space dew point temperature based on the owners desired space conditions. Once done, the designer must identify all potential condensation spots in the building. A typical pool design of 82°F 50-60% RH has a peak dew point of 67°F. Therefore, any surface with a temperature below 67°F will condense moisture.

A vapor retarder is a material that restricts the rate of water vapor diffusion through the ceilings and walls of a building when below dew point temperature occurs.

Failure to install the vapor retarder in the proper location will result in condensation within the structure and lead to tragic structural failure. Always ensure the vapor retarder is sealed at all the seams.

- The Vapor retarder must be on the warm side of the dew point temperature in all walls, ceilings and floors.
- All exterior windows, doors and skylights must be fully blanketed with warm supply air. 3-5 CFM/ft² is recommended.

Step 7: Energy & LEEDs Considerations

The energy consumption and performance implications of the building type and operating conditions must be discussed with the owner.

Operating conditions

Operating conditions have a tremendous impact on operating costs. It is critical that the owner understand that at the same water temperature a pool in a room at 78°F 50% RH will evaporate almost 35% more than that exact same pool in an 85°F 50% RH room. The pool room should be kept as warm as possible but still be comfortable to the patrons. Reduced evaporation in turn reduces the dehumidifier size and runtime as well as reduces the pool water heating requirement.

Heat recovery pool water heating

The dehumidifier's pool water heating option should be considered. It is site recovered energy and has a very attractive payback period. This process has an impressive COP of close to 8! The use of the pool water heating option also satisfies ASHRAE Energy Standard 90.1.

If it is chosen ensure that the pool water circuit is designed to allow water to be delivered to the unit reliably.

- Provide a separate circulating pump.
- Use the controls provided by the Seresco unit to control the auxiliary water heater operation.
- Install the auxiliary pool water heater downstream of the dehumidifier for backup heating.
- Ensure the pool water chemicals are introduced downstream of the unit, auxiliary heaters and pumps.

Heat Recovery on minimum outdoor air and exhaust air

Outdoor ventilation air is essential for maintaining good IAQ in the pool and is a code requirement. The natatorium also needs to be maintained at a slight negative air pressure, so warm energy rich air needs to be exhausted. These two airstreams at vastly

different conditions present a perfect opportunity for heat recovery.

Seresco provides unit mounted heat recovery between these two air streams using a glycol run-around loop. This approach to heat recovery offers the best performance and design flexibility while staying in the smallest possible cabinet. They are also easily sized to meet the specific requirements of your facility. The result is a compact, cost effective heat recovery option that actually fits into a mechanical room.

Adding the glycol run around loop heat recovery option to your Seresco unit in a northern installation will typically realize a one year payback on your investment!

- The heat recovery device should be suitably protected from corrosion and freezing.

Condensate Reclaim

Verify with local codes whether condensate return to the pool is allowed. While condensate is generally

considered gray water, this condensate is actually cleaner and if introduced upstream of the filters and chemical treatment can help realize considerable water savings on site.

- If allowed by local codes, the condensate reclaim from your Seresco unit can be the equivalent of one pool fill annually!

Refrigerant Reduction

Seresco's new Protocol design reduces the refrigerant system charge compared to a traditional compressorized direct expansion type unit by a whopping 75%! There is no operation penalty to this new design and is quickly becoming the new industry standard.

- The Protocol unit's refrigerant charge is so low that no special ventilation may be required in the mechanical room!

Popular Configurations and System Designs

Specific market segments have gravitated towards unit designs because of their overall features, ease of installation, first cost and system performance:

Hotel and Residential Market

These are smaller pools with light usage compared to institutional pools. Besides the pool water heating option, they tend to go without some of the other heat recovery options that are usually incorporated into larger units. This configuration is usually refrigeration based with the outdoor ventilation air connected directly to a special intake at the unit. The space heating coil is also mounted internally. The exhaust fan is usually installed in the space with its intake over the hot tub. They tend to be vertical units and installed in the pool filter room. The air conditioning heat rejection is to a remote outdoor air-cooled condenser.

The vertical configuration in Figure 14 is very popular in hotel and residential applications because of their compact footprint and 2-side service access. These PV and NV models are

Figure 14 – Vertical Unit Configuration

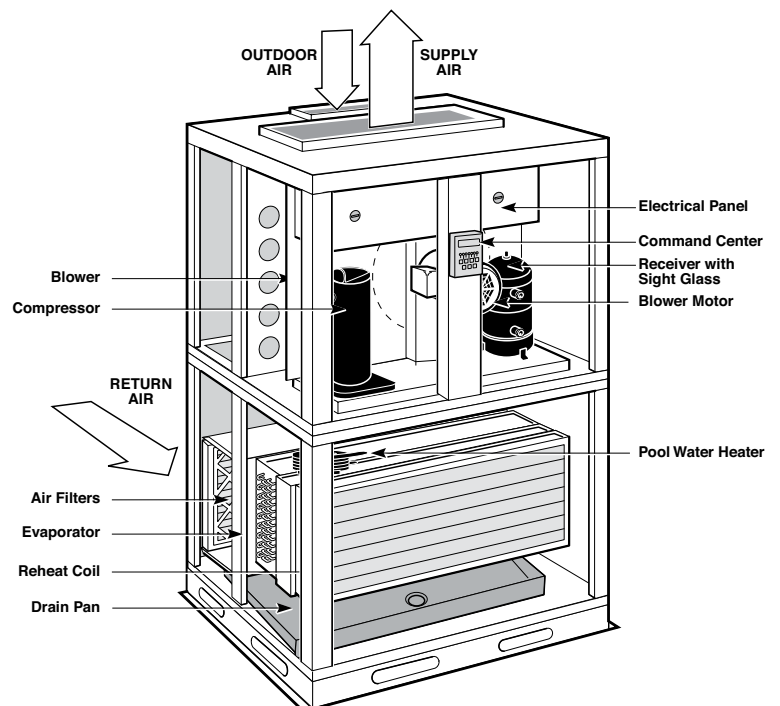

available with or without pool water heating. The maximum size is limited to 100 lb/h capacity.

There are a multitude of other configurations available should a horizontal unit or outdoor packaged system suit the project better. The heat rejection can also be to a geothermal loop, dry cooler or cooling tower.

Purge – Economizer Layout

This configuration has enhanced air quality control capabilities and also offers economizer operation. These

systems are designed with multiple dedicated duty exhaust fans. The first exhaust fan (EF1) is sized to maintain the room's negative pressure by exhausting 10% more room air than is introduced to the space as code mandated ventilation outdoor air. The second exhaust fan (EF2) sized to allow for full purge/evacuation of the space with a 100% outdoor air mode.

Figure 16 shows a unit in "Normal Operation" where EF1 maintains the room's negative pressure. EF1 can be unit mounted or remotely installed with its intake located above the whirlpool whenever appropriate. EF2 is normally off and operates only when a purge or economizer demand exists.

The outdoor air intake is set to introduce the code required ventilation outdoor air (aka Minimum OA) until the system goes into Purge or Economizer when it opens to 100%.

These minimum outdoor air and EF1 airstreams at vastly different conditions present a perfect opportunity for heat recovery. Seresco provides unit mounted heat recovery between these two air streams using a glycol run-around loop. The coils just slip into the airstreams of this unit configuration. This approach to heat recovery offers the best performance and design flexibility while staying in the smallest possible cabinet. Figure 17 shows a unit in "Normal Operation" with the glycol heat recovery coils in place.

Figure 15 – Typical Hotel and Therapy Pool Layout

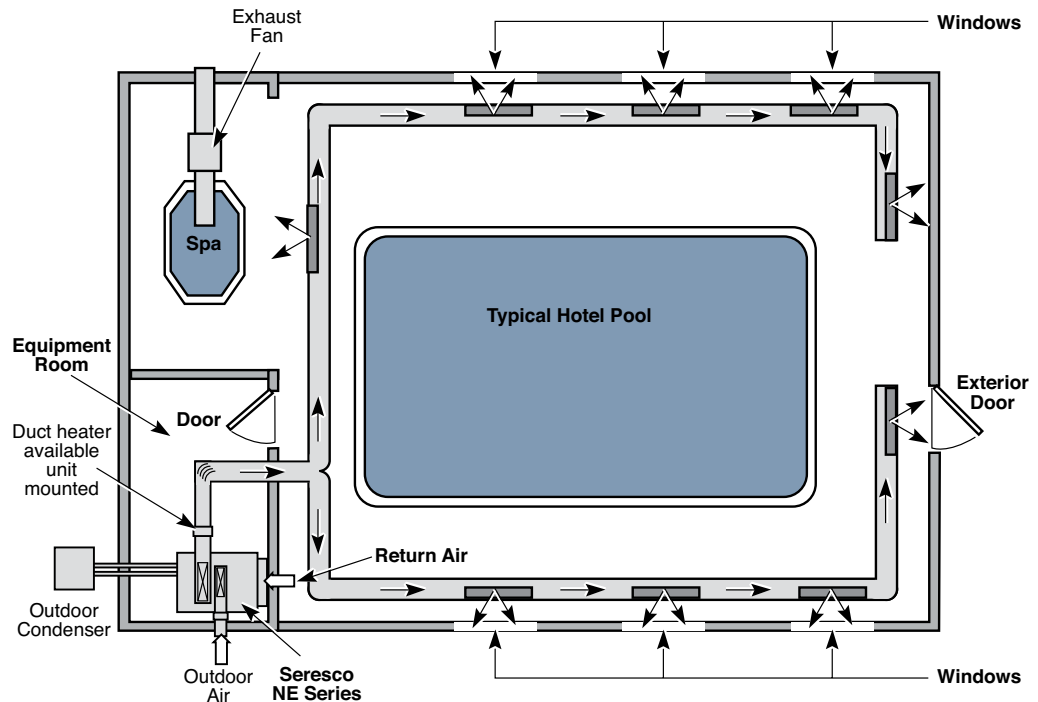

Adding the glycol run around loop heat recovery option to your Seresco unit in a northern installation will typically realize a one year payback on your investment!

If the system design has remote exhaust fans, the glycol run around loop can still be used for heat recovery. A significant added benefit to heat recovery is the tempering of the outdoor air before it can mix with the system air. Tempered outdoor air will not create condensation problems during the cold weather. In northern climates it is very common to add a separate heating coil for the outdoor air if heat recovery is not being used.

NOTE: Traditional supply & return fan configurations with a mixing box are not a good choice for a Natatorium application. There are three significant shortcomings compared to the Seresco method:

- A traditional mixing box modulates air from 0-100% and cannot offer heat recovery on the minimum outdoor air and exhaust air streams.
- The fan motor consumption can be double of the Seresco method.
- On a pool application the mixing box is placed after the evaporator coil. This means conditioned air is exhausted! The gross evaporator coil output is not what gets delivered to the space.

Figure 16 – Normal Mode

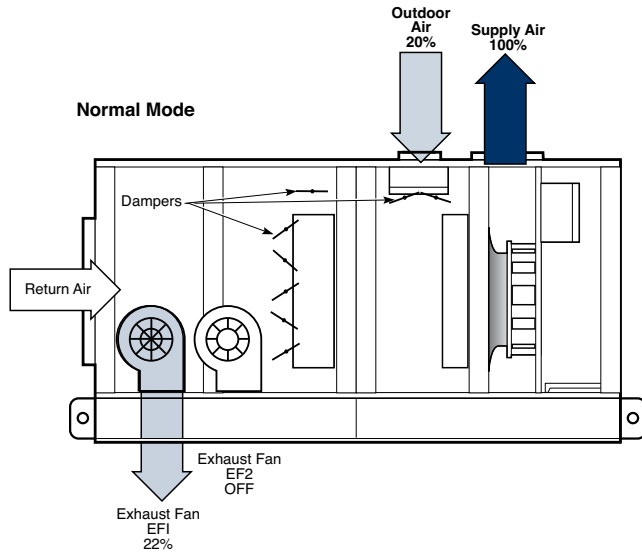

Figure 18 – Purge or Economizer Mode

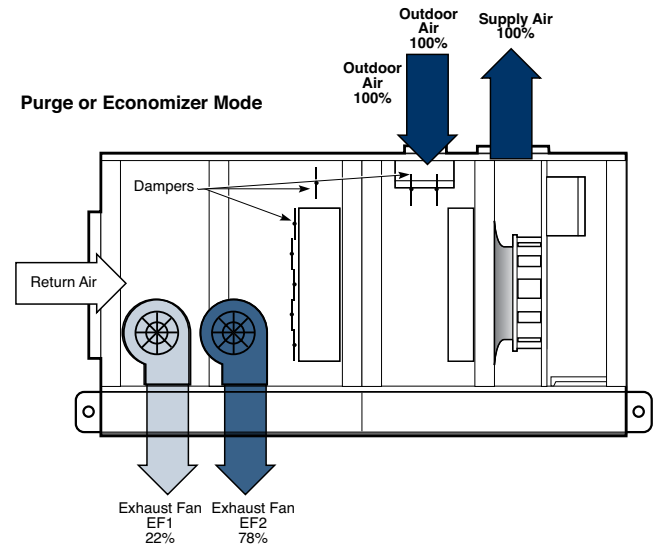
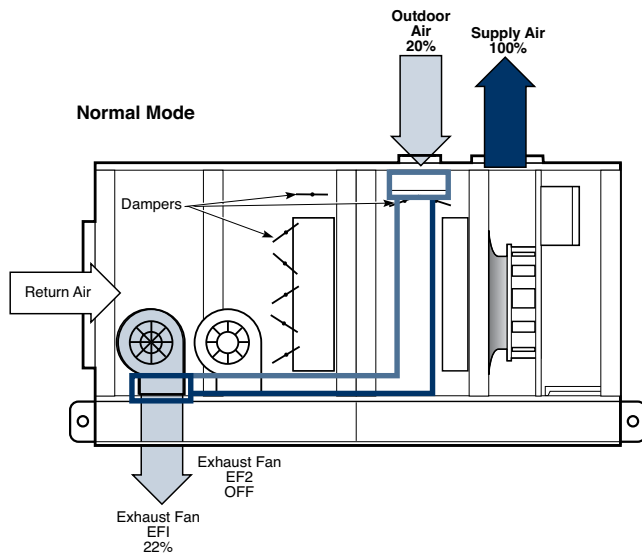

Figure 17 – Normal Mode with Glycol Heat recovery



3. Built-in economizer operation. All controls and mechanical equipment are already in place to operate in economizer cooling and dehumidification modes whenever the outdoor air conditions are suitable. This offers the operator the most economical year round system operation.
4. This configuration consumes significantly less energy than traditional supply/return fan economizer systems with a mixing box because of the specific duty exhaust fans. They only operate when needed compared to the supply and return fan configuration that has both full sized fans operating year round. EF1 is a very small horsepower fan. EF2 operates only when called upon or when the outdoor conditions are suitable for economizer operation whereas the traditional approach has 2 full sized fans operating year round.

Figure 18 shows a unit in “Purge-Economizer mode”. There are three significant benefits to this configuration:

1. 100% air purge capability available at any time. The operator can super-chlorinate (shock) the pool, and ventilate the space with 100% outdoor air to quickly clear out any airborne chemicals.
2. It also allows for a means to deliver a complete air change of the space should it require a quick purge.

These system features can be designed into the ductwork or incorporated into the unit as a complete package.

Table 10 – Exhaust Fan Operation

Exhaust Fan Operating Sequence Example			
	Exhaust Fan EF1	Exhaust Fan EF2	Outdoor Air
Normal Operation	ON	OFF	Minimum required by code
Purge – Economiser Mode	ON	ON	100%

Dehumidifier Specifications

In order to ensure the system performs reliably and that the equipment is suitable for an indoor pool environment, there are several items to look for in a quality product. The materials and components used must have adequate corrosion protection. Seresco uses only the best available materials, coatings and paints to ensure the longest possible unit lifespan. For example, the sheet metal used has an automotive grade galvanizing that is intended to withstand road salt. This already corrosion resistant sheet metal is then given a mill applied zinc phosphate primer followed by an exterior grade silicone modified polyester top coat.

Service Vestibule

The best way to protect a component from corrosion is to keep it away from the chlorine. All vital components in a Seresco unit are located out of process airstream, housed in a protective service vestibule. These key components include compressors, receivers, pool water heaters, contactors, control valves and electronics. Components in the airstream are kept to an absolute minimum, ensuring very few opportunities for corrosion. There is an added benefit to using a service vestibule – 100% of the evaporator's sensible cooling is delivered to the space for cooling. Systems with compressors, receivers and pool water heaters in the process air stream add so much heat that their unit cooling output needs to be de-rated by as much as 25%!

Microprocessor Control

The dehumidification system controls the entire Natatorium environment. There are many aspects to this control, and feedback regarding system operation is vital to the building operator. Seresco's CommandCenter microprocessor controller has full range of unit mounted sensors, pressure transducers and remote sensors that can all be accessed from the Keypad, building management system interface or over the internet using Seresco's WebSentry web browser. All necessary information regarding the conditions in the space and system operation are always at the fingertips of the operator.

WebSentry

Factory monitoring of your system and dehumidifier 24/7 for no charge! With WebSentry all necessary information regarding unit operation can be viewed from a remote computer. Setpoints can be adjusted, sensors can be recalibrated, and unit performance can be monitored. Run a Cat 5 ethernet cable to the unit and plug it in.



There is also a Smartphone application for WebSentry!

Alarm at the unit? It'll email you! Unit alarms will generate e-mails to any email address that you add to the contact list! Installing contractors and contractors trying to secure service contracts can be set up to access their units. The facility owner, especially those in remote locations will have a much more affordable means of ensuring their units are monitored and service is supervised over the internet by factory technicians.

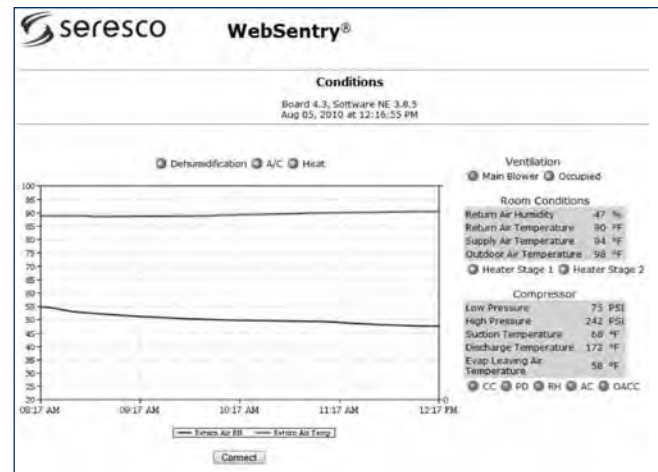

Factory certified service companies can now offer pool operators 24-hour monitoring.

This is the new standard in customer satisfaction and unit reliability.

Refrigerant Pressure Transducers

Unit mounted pressure transducers allow the operator or serviceman to access the vital refrigerant pressures through the operator panel of the microprocessor (or remotely via the internet) rather than having to connect a set of refrigerant manifold gauges. This is the most important operation and diagnostic information for any refrigeration system and the ability to access this information at any time is a significant benefit. Systems without refrigerant pressure transducers require a service technician to visit and connect gauges anytime information regarding the refrigeration circuit is desired.

The refrigeration pressure information from these transducers is used in the control of the Seresco unit. Seresco is the only company in the industry that uses real time refrigeration pressure information in their control sequence. The result is a significantly more reliable unit.

Refrigerant System Charges

Seresco offers systems with R410A and R407C refrigerants. These blended refrigerants are expensive and there are steps the designer can take today to ensure the owners refrigerant costs in the future are minimized:

- Specify the maximum total allowable system charge.
- Keep outdoor air-cooled condensers as close to the dehumidifier as possible.
- Water-cooled or closed circuit fluid cooler unit configurations have the smallest charges. These units come with a complete factory charge and require no onsite refrigeration piping or charging.

Seresco's Protocol™ Design uses 75% less refrigerant compared to a traditional split system.

Receiver Refrigerant Level Indicators

Sight glasses mounted on the receiver allow for easy refrigerant charge adjustment without the expense of evacuation and weigh-in techniques. Seresco is the only manufacturer to use this time and money savings feature.

Direct Drive Plenum fans with VFD

Direct drive plenum fans with VFD offer the most efficient means of moving air while using the lowest possible fan energy. Belt driven systems are a service and maintenance concern and are an inefficiency that consumes more energy. VFDs allow for easy supply air balancing without changing pulleys or belts.

Coated Airside Coils

All coils exposed to the pool air must be corrosion protected. Seresco fully dips all coils to ensure 100% of the coil is protected from corrosion with the best coatings available in the industry.

Warranty

Five (5) year extended parts only warranties on compressors and airside heat exchangers are generally a good investment. 10-year coils warranties are also available but can be costly.

Commissioning

The final performance review of a dehumidifier can only be completed once the natatorium is operating at design conditions. Often the initial start up is done with a cold pool. These facilities require a follow up visit once the water has reached design conditions. Specify that a factory trained/certified service company perform the start up and commissioning. This may not be the installing contractor.

First Year Labor

If the installing contractor is not doing the unit start up, specify who should be responsible for the first year labor warranty.

Design and Installation Details

The designer should address the following issues to ensure the unit is properly installed and can be serviced and maintained.

Access Space

No Access = No Service or Maintenance. All NE series dehumidifiers have been designed to require access on only two sides. Allow a minimum of 36 inches of clearance on the sides indicated for piping and service access. Mirror access units are also available.

Pool Water Heating (Option)

Seresco has developed the simplest and most reliable water heating configuration in the industry. NE Series dehumidifiers can be equipped with water heating capabilities. The annual energy savings realized as a result of the water heating capabilities makes this unit configuration one of the most energy efficient units in all of the HVAC industry.

The NE unit requires only a fraction of the total water being circulated by the main filter system.

- The water circuit should tap off the main pool water line downstream of the main filter and upstream of the auxiliary pool water heater and chemical feeder. (See figure 20)
- An auxiliary water pump to deliver the unit's required water flow rate is recommended. This is an open system and the pool's main circulating pump can rarely accommodate additional system pressure.

Outdoor Air Cooled Dry Cooler or Condenser Installation

This heat exchanger is used in air conditioning mode where it rejects unneeded heat from the space to outdoors. Proper installation is essential to ensure it can function as intended. Proper airflow and refrigerant piping are paramount.

Figure 19 – Recommended Access Space

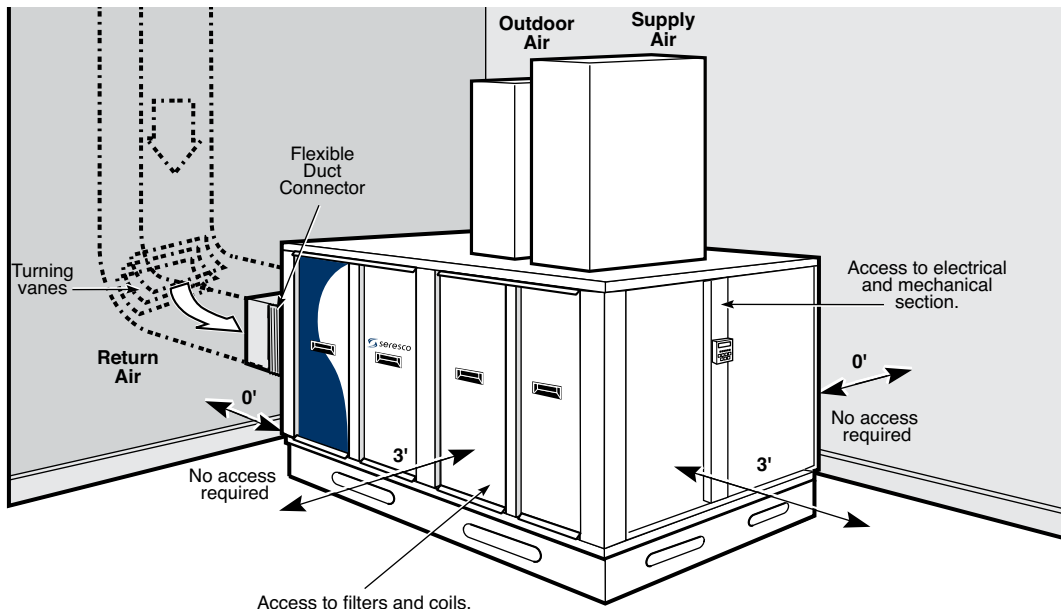
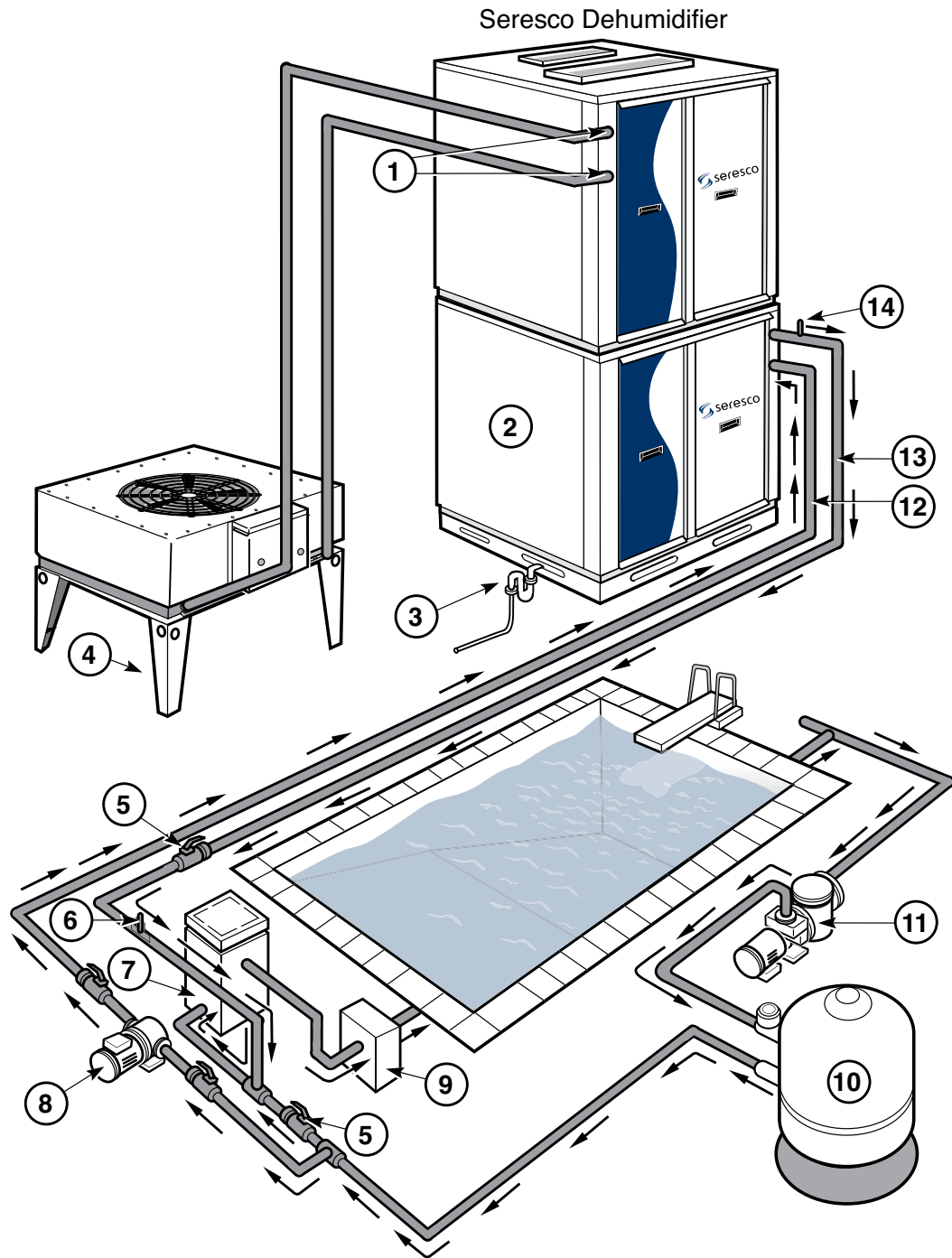

Figure 20 – Proper Pool Water Heater Piping Installation



Legend

- | | |
|---|-----------------------------|
| ① Refrigerant Piping to Outdoor condenser | ⑨ Automatic Chemical Feeder |
| ② Seresco Dehumidifier | ⑩ Pool Filter |
| ③ P-Trap | ⑪ Main Pool Pump |
| ④ Outdoor Condenser | ⑫ Water Inlet |
| ⑤ Ball Valve | ⑬ Water Outlet |
| ⑥ Flow Meter | ⑭ Air Vent |
| ⑦ Auxiliary Pool Heater | |
| ⑧ Auxiliary Pump | |

- Ensure an appropriate maximum ambient air temperature has been specified.
- Ensure the unit has proper airflow. A perimeter of free area equal to its width must be provided.
- Use line sizes as specified by Seresco.
- To avoid potential seasonal system charge problems with outdoor condensers, ensure the installed line lengths are never longer than indicated on the plans and specifications.
- If the condenser is installed above the dehumidifier, ensure the hot gas line has proper oil traps.
- Contact Seresco if the condenser is installed more than eight (8) feet below the dehumidifier.

Figure 21 – Typical Outdoor Condenser Installation

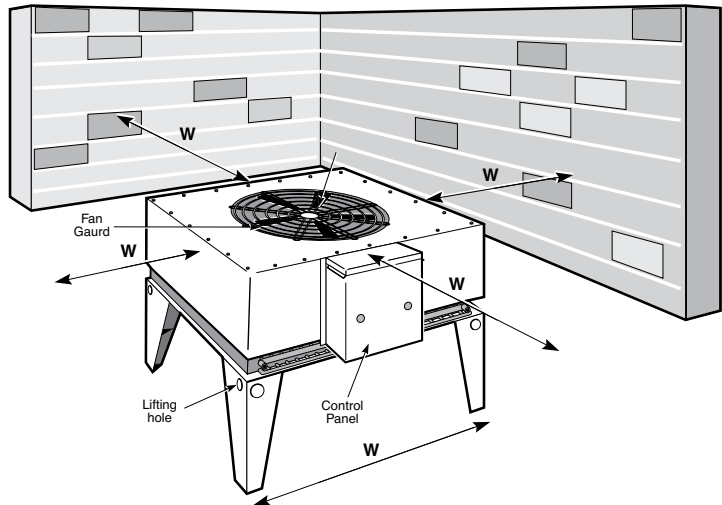
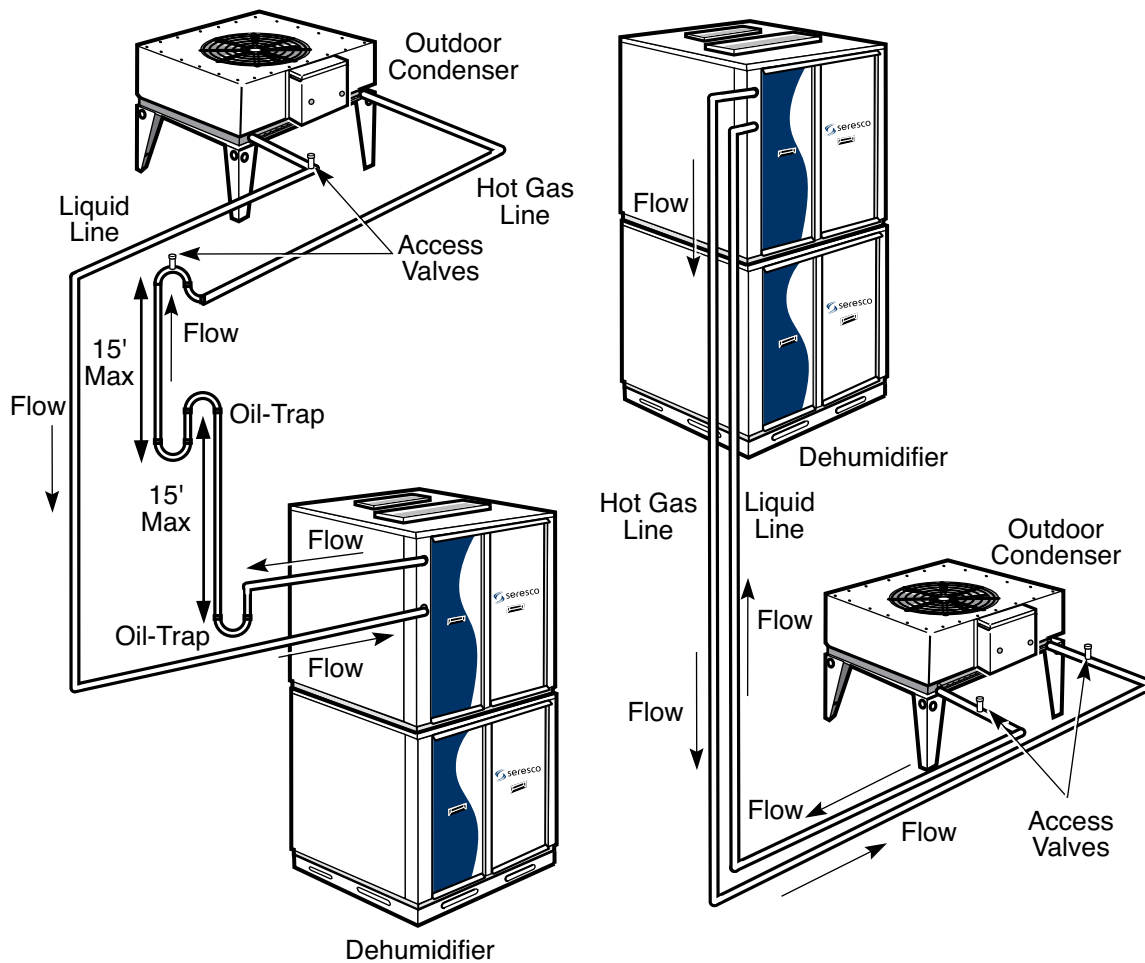

Figure 22 – Typical Outdoor Condenser Installation



- Specify the lines be nitrogen purged while being brazed to help avoid scaling inside the pipe.

Unit mounted sensors, all accessible via the Internet include:

Control Wiring

The NE Series dehumidifiers have all necessary sensors unit mounted and set points pre-programmed at the factory. Remote duct heaters, outdoor air-cooled condensers, auxiliary pool water heaters and remote exhaust fans all require interfacing with the dehumidifier. The microprocessor has been programmed to control their operation. An Ethernet connection to the Internet allows all functions to be monitored by trained professionals with Seresco's WebSentry. It is the final step to ensure the facility operates trouble free.

- Refrigerant high pressure
- Refrigerant low pressure
- Return air temperature
- Return air relative humidity
- Pool water temperature (in and out)
- Outdoor air temperature
- Supply air temperature
- Evaporator air temperature
- Compressor superheat temperature
- Airflow
- Bypass damper setting

Figure 23 – Control Wiring

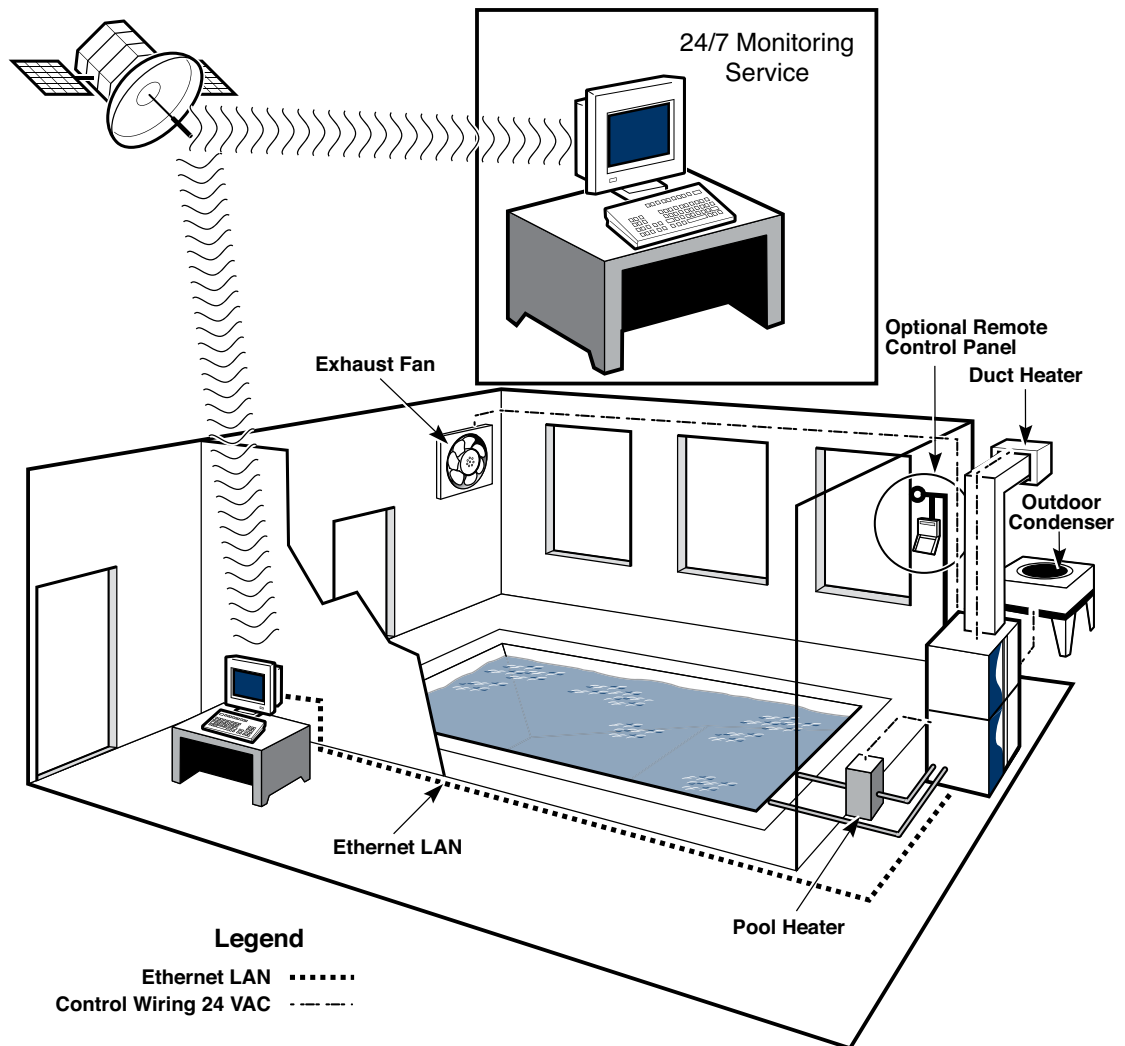

Frequently Asked Questions

The Key

What is the most important HVAC design aspect in a Natatorium?

Get the air distribution right. Get air to the breathing zone. Get your condensation concerns covered. You can do a perfect job everywhere else, but if you don't get air down to where the occupants are you will have a problem job. If the windows are sweating, you will have a problem.

Duct Material

What duct material is recommended?

Galvanized sheet metal or Fabric Duct are recommended. Aluminum is also suitable. Do not use Stainless steel. Painted galvanized spiral ductwork is popular when the duct is exposed. Fabric duct is gaining popularity and is a good option. Regardless of which duct material is chosen, it must be designed so that the air is directed to where it is needed in the space.

Fabric Duct

Is this duct material recommended?

There are many benefits to fabric duct. It is inexpensive, easy to install, lightweight, won't corrode and can be ordered in virtually any color. Special care must be taken when using fabric duct. Ensure the material grade does not 'leak' air and the diffusers must have suitable throw and be sewn in where they will deliver air to where it is needed in the space.

Wave Pool and Water Park Features

What are some of the design challenges? Calculating the evaporation rate and maintaining good

IAQ. These facilities have high dehumidification loads in a very concentrated space due to the water features. They tend to have heavy bather loading and also require more outdoor air than a traditional natatorium. Contact your local Seresco representative for additional design assistance.

Pool Covers

I have one. Do I still need a dehumidifier?

Yes. The dehumidifier is sized for the load presented by the pool when in use. Manual pool covers are often not used but are essential in the event of a power failure to the automatic pool cover. Pool covers do not completely stop evaporation, but they do reduce it. Consequently, use of a pool cover will reduce the run time of the dehumidifier.

Wet Deck

When calculating outdoor air requirements for the pool, why consider the wet deck area instead of the total deck area?

ASHRAE interprets wet deck as 6 foot perimeter around the pool. Outside air is needed to dilute the chemical off-gassing from the pool water & wet deck areas. Portions of the total deck area that will never get wet won't off-gas chemicals either. By designing the outdoor air requirement to match the wet deck area you can significantly reduce the outdoor air heating costs without any negative impact on the IAQ.

Suspended Ceilings

Is it true that suspended ceilings are not recommended?

It is true due to the ceilings are very vulnerable to collect condensation and have corrosion problems. If a facility has a suspended ceiling, the area above the suspended ceiling must be conditioned as would the rest of the pool space.

Skylights

What are the design concerns?

In cold climates they will be vulnerable to condensation. The large quantity of supply air required for condensation control is often a problem because ductwork is necessary, which often causes concerns about aesthetics with the owner.

Swim Meets

My Facility will host Swim Meets. How does this impact dehumidifier selection?

Facilities that host swim meets have two distinct modes of operation, "Normal" and "Swim Meet".

- Normal Mode is how the facility operates when not hosting a swim meet. This may have warmer water temperatures and high activity factors for water agitation. The Outdoor ventilation air requirement here is at baseline.
- A swim meet will have a large spectator load and possibly a load at the deck if many competitors stay there during the competition. The designer must get these numbers from the owner. During the swim meet the pool swimmer density in the water is less than during normal operations. There is an additional outdoor ventilation air requirement for the spectators. The extra outdoor air gets added to the baseline requirement.

Condensate

Can I return condensate from the Seresco dehumidifier back to my pool?

It is recommended that the condensate from the dehumidifier be returned to the pool when local codes permit. This is worth LEED points. The amount of condensation recovered in one year is equivalent to one complete pool fill. When allowed, the condensate is returned to the pool filtration loop either upstream of the filter or into the skimmer.

Cooling

Can I upsize my Seresco dehumidifier for more cooling?

Yes. If the model initially selected has a sensible cooling capacity less than what is required, a larger unit is usually the most cost effective solution. Two compressor systems can also be staged to help deliver only as much cooling as is required at any given time.

Air Direction

Should there be air movement at the water surface?

Yes. The U.S. Olympic Committee (USOC) does recommend some air movement at the water surface for its facilities to dilute a higher concentration of chemicals where the swimmers breathe. Significant air movement at the water surface (above 30 fpm per ASHRAE) is not recommended however, as it does not improve the IAQ and increases the evaporation rate and affects bather comfort.

Return Air Intake Location

Where should I locate my return duct intake?

Ideally it should be located in a position to compliment the supply duct air distribution pattern. If you have overhead supply duct, then low returns are effective. If the facility is large, several return intakes are recommended.

Do not place a return intake near a whirlpool. Whirlpools spew high concentrations of chemical and you don't want those introduced to you HVAC system. It is recommended that these chemicals be source captured with exhaust air intake and removed from the space before they have a chance to diffuse instead.

Duct Insulation

Why do I need duct insulation?

When ductwork passes through unconditioned areas it should be thermally insulated with duct wrap on the outside. This will prevent condensation and heat gain/loss.

Acoustic insulation from the unit up to the first supply and return duct turns can help reduce air noise.

Indoor Water Parks

What are the key design recommendations?

These facilities are considerably more complex than a traditional Natatorium. They generally have unique architectural and water features. The high occupant density and large dehumidification load makes it additionally challenging. The experts at Seresco are ready to assist with this complex task!

All Glass Structures

What are some of the design challenges?

Condensation and the large volumes of supply air required to condition the space are big challenges. Condensation is obvious. The entire structure is essentially a window and must be blanketed with air. The heating and cooling requirements will be very high. To address these issues a significant amount of supply air will be required. It is not uncommon to see air changes well in excess of 12 per hour in these facilities.



Seresco Design Checklist for Traditional* Pools

Having a checklist comes in handy when designing complex jobs. Seresco is pleased to provide this dehumidification design checklist for your convenience. We also provide our complete Natatorium Design Guide online, along with extensive specification and design resources, including load calculation software.

Please visit: www.SerescoDehumidifiers.com/engineers.html

Key Design concerns for traditional* pools:

1. Operating conditions in writing from end user (pool water temperature, room air temperature)
2. System supply CFM delivers 4-6 air changes per hour. The room volume dictates the supply CFM.
 - Supply air gets to the 'breathing zone'
 - Good overall air pattern covering the entire space
 - No short circuiting
3. Outdoor air CFM per Standard 62
 - Baseline: 0.48 CFM/ft² of water and wet deck for regular pool
 - Add 7.5 CFM per spectator (swimmers are not considered spectators and are covered in the baseline OA CFM)
4. Exhaust Air
 - Room is at slight negative pressure (0.05 to 0.15 inches of water column)
 - 110% the outdoor air CFM is generally recommended
 - Source capture contaminants – Exhaust air drawn from the whirlpool or any other warm or highly active water area
5. Load Calculation
 - Latent load (pools, OA and spectators)
 - Sensible cooling load has been calculated for the space design temperature
 - Heating load has been calculated for the space design temperature and includes OA
6. Condensation and Vapor Migration
 - Vapor barrier on the warm side of the dew point temperature in all walls, ceiling and floors
 - All exterior windows, doors and skylights are fully blanketed with supply air (3-5 cfm per sq ft)
7. Energy & LEEDs Considerations
 - Energy Standard 90.1 – pool water heating option
 - Heat recovery between the minimum OA and minimum EA
 - Condensate reclaim
 - System refrigerant charge reduction – Protocol Design
8. Swim Meet Mode
 - Number of spectators and competitors expected?
 - Spectator areas
 - Spectator Area has 6-8 Air Changes per hour of supply air
 - Airflow to spectator seating areas
 - Micro climate via separate air handler for larger spectator areas
9. Service and Maintenance
 - Internet monitoring
 - Unit is accessible
 - Unit has adequate service clearance

* Please contact factory for Waterparks and pools heavy with water features. Design standards have been established for 'traditional' bodies of water and do not adequately address the special needs of these facilities.