



# NORTH STAR MUTUAL'S

Guide To Safe  
Installation and  
Operation In

# WOOD HEATING

## WOOD HEATING

Item	Page #
Characteristics of Wood .....	14
Chimney Caps or Spark Arrestors .....	8
Chimneys.....	7-8
Double Venting Concerns.....	9
Fireplaces .....	10
Fireplace Inserts .....	10-11
Outdoor Wood Heat.....	12
Recommendations for Safe Woodburning.....	13-14
Stove Pipes .....	4
Wall Pass Throughs.....	4-6
Wood Furnaces .....	3
Wood Stoves - Clearance and Reductions.....	1-3
Wood Stoves - General Requirements.....	1

**North Star Mutual is concerned about protecting the lives as well as the property of its policyholders. Therefore, as a means of promoting home safety, we have developed the following brochure in the hope that both life and property may be saved by practicing safe wood heating.**

## WOOD STOVES - GENERAL REQUIREMENTS

Preferably, a woodburning unit should be a stove, furnace or fireplace that has been tested and listed by Underwriters Laboratories or some other formally recognized testing facility. Stoves which are listed will have a metal tag affixed, showing the recommended clearances to combustibles. In the absence of such a tag, the stove is considered "unlisted" and will require 36" of clearance to any unprotected combustible. Various methods of reducing the clearance requirements are discussed on Page 3.

**Mobile homes**, because of their construction characteristics, require special woodheating considerations. Generally speaking only factory-installed woodstoves and fireplaces are acceptable. All wood heating equipment must be UL approved for use in a mobile home.

Woodburning stoves should be placed on a non-combustible floor surface or floor pad which extends out **18"** on all sides.

A licensed plumbing and heating contractor should install all woodheating devices.

**Barrel stoves and other homemade devices are not allowed.**

## RECOMMENDED CLEARANCE FOR NON-LISTED WOODBURNING UNITS

### Clearance To Any Combustible Material

Back of stove to wall	36 inches
Front of stove to wall	36 inches
Sides of stove to wall	36 inches
Top of stove to combustible (mantel or ceiling)	36 inches

This is one of the clearance reduction methods which are illustrated on the following page.

CLEARANCE TO COMBUSTIBLE WALL WITH PROTECTION OF 24 GAGE SHEET METAL MAY BE REDUCED UP TO 66%.  
(STOVEPIPE 50% ONLY)

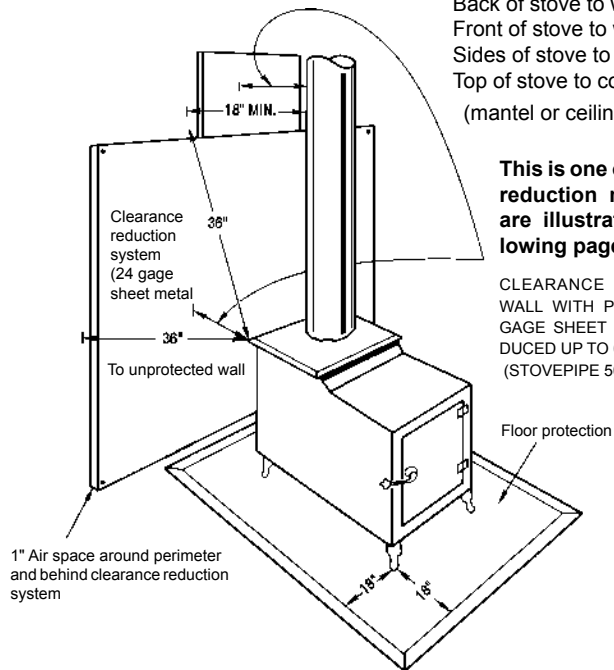

1

## RECOMMENDED CLEARANCE FOR WOODBURNING UNITS Continued

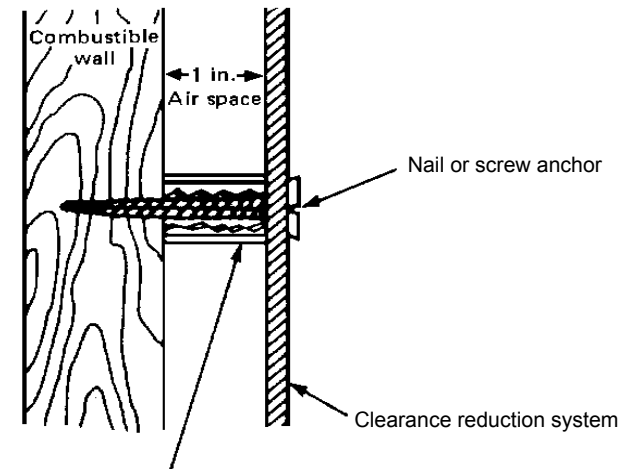
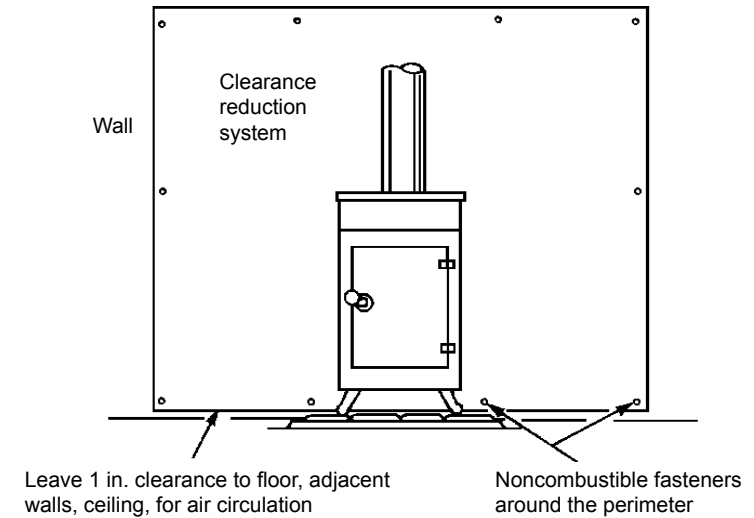

1 in. Noncombustible spacer such as stacked washers, small diameter pipe, tubing, or electrical conduit.

2

## REDUCTION OF APPLIANCE CLEARANCE WITH SPECIFIED FORMS OF PROTECTION

Clearance Reduction System applied to combustibles	Woodstove maximum clearance reduction from 36"	Stove pipe maximum clearance reduction from 36"	As	
			wall protector	ceiling protector
<b>WALLS</b>				
(a) 3-1/2 in. (90mm) thick masonry wall without ventilated air space	33% or 24"	33% or 12"	12	--
(b) 1/2 in. (13 mn) thick insulation board over 1 in. (25mm) glass fiber or mineral wool batts	50% or 18"	50% or 9"	9	12
(c) 3-1/2 in. thick masonry wall with at least a 1" ventilated air space *	66% or 12"	50% or 9"	6	--
(d) 24 gauge sheet metal with at least a 1" ventilated air space *	66% or 12"	50% or 9"	6	9
(e) 1/2 in. thick insulation board with at least a 1" ventilated air space *	66% or 12"	50% or 9"	6	9

\* Non-Combustible Spacers should be used to provide the 1" air space

## WOOD FURNACES

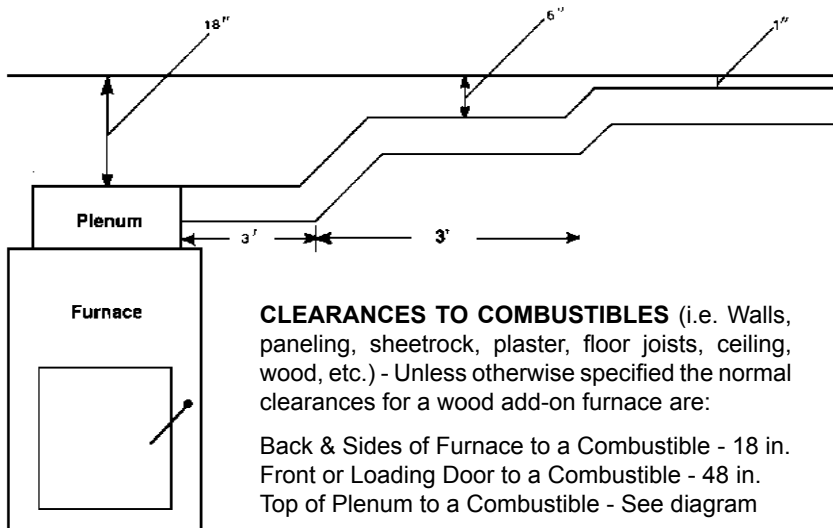

## STOVE PIPES

Stove pipes are a means of connecting the heating appliance to the chimney. **THESE ARE NOT INTENDED TO BE USED AS CHIMNEYS!!!** As a general rule, the stove pipe should be as short and straight as possible, preferably 5 feet or less. There should be no more than two 90 degree elbows and the pipe should slope down towards the stove at a rate of at least 1/4 inch per foot of pipe.

**A single-wall stove pipe must have 18 inches of clearance to any combustible, including wooden floor joists.**

Heat reclaimers are devices placed inside of a stovepipe containing a fan which draws off the heat normally lost up the chimney. This causes a reduction in stack temperature and results in excess creosote formation. **These devices should not be used.**

Black stove pipe is designed for use with a wood appliance. Galvanized stove pipe should not be used as this gives off zinc oxide, a toxic gas. Pipe segments should be fastened together using sheet metal screws.

## WALL PASS THROUGHS

Wall pass throughs are used to connect a woodburning unit located inside a building with a masonry chimney located outside of that room or building.

Older wall pass throughs were manufactured using specifications or materials that used to be considered safe but have since been shown to be extremely hazardous.

There are four wall pass through methods which are acceptable:

1. A factory built, UL listed wall pass through device which requires only 2 inch air space from combustibles.
2. Surrounding the stove pipe with 3-1/2 inch brick twelve inches in all directions.
3. Using a 1 foot or larger section of UL listed, high-temperature metal chimney with a 9 inch air space to all combustibles.
4. Solid Insulated Factory Built Chimney - length same as 3. above - except chimney length needs 2" in diameter larger inside than chimney connector (stovepipe). This will equal 1" around chimney connector than only a 2" clearance around chimney is needed to all combustibles.

# WALL PASS THROUGHS ILLUSTRATED

## 1. Manufactured Wall Pass Thru

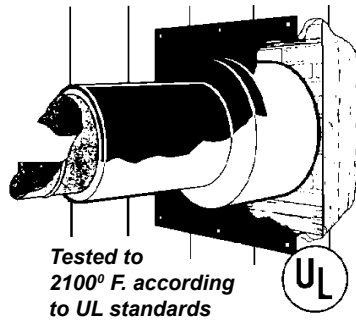

## 2. 3 1/2 Inch Brick Surrounding Stovepipe

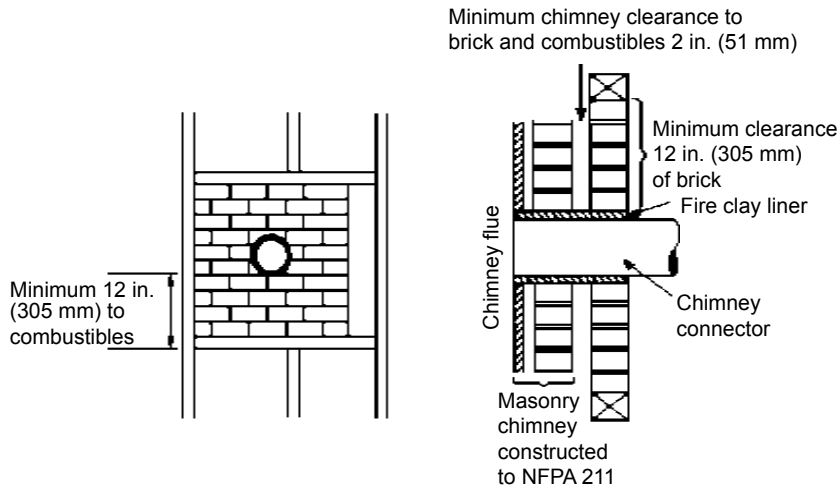

# WALL PASS THROUGHS ILLUSTRATED CONTINUED

## 3. Solid Insulated UL Listed Factory - Built Chimney Length with a 9" clearance required

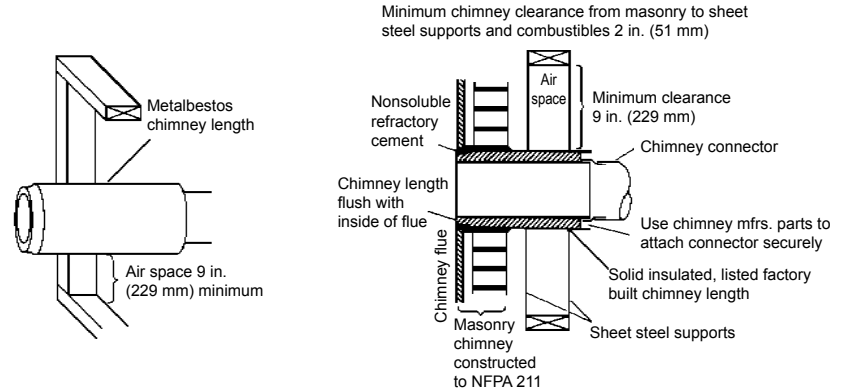

## 4. Solid Insulated UL Listed Factory - Built Chimney Length with a 2" clearance required.

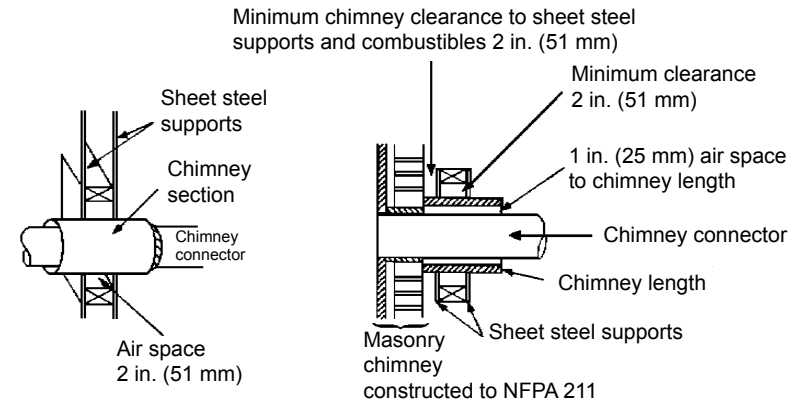

Solid insulated listed factory-built chimney length with a inside diameter 2 in. (51 mm) larger than the chimney connector and having 1 in. (25 mm) or more of insulation, serving as a pass-through for a single wall sheet steel chimney connector of minimum 24 gage (0.024 in. (0.61 mm) thickness, with a minimum 2 in. (51 mm) air space between the outer wall of chimney section and combustibles.

Minimum length of chimney section shall be 12 in. (305 mm). Chimney section concentric with and spaced 1 in. (25 mm) away from connector by means of sheet steel support plates on both ends of chimney section. Opening shall be covered, and chimney section supported on both sides with sheet steel supports of minimum 24 gage (0.024 in. (0.61 mm) thickness.

Supports shall be securely fastened to wall surfaces on all sides and shall be sized to fit and hold chimney section. Fasteners used to secure chimney sections shall not penetrate chimney flue liner.

## CHIMNEYS

The National Fire Protection Association (NFPA) requires that solid fuel woodheating devices be connected to a Class A or "all-fuel" chimney. Class A chimneys may be constructed of either masonry or prefabricated metal. These chimneys require a 2" clearance to any combustible.

**Brick or block chimneys** must be lined, using either a clay tile or stainless steel liner. Special attention should be given to older brick chimneys, as age, heat, and moisture causes the mortar to weaken, making the chimney unsafe. Deteriorated chimneys need to be repaired by a trained professional. A chimney can be relined using one of the following methods:

1. A poured relining system.  
Examples: Ahrens product or a solid flue system.
2. Installing a stainless steel liner rated up to 2100°F.

**Pre-fab metal chimneys** come in two types, solid pack or triple wall. The solid pack (such as Metalbestos brand) has a double wall with a layer of insulation between the walls. The triple wall has three walls with air spaces between each wall. These chimneys should possess a UL label "HT" signifying that the chimney has been tested safe at high temperatures (up to 2100° F.) Metal chimneys manufactured before 1982 are only fire rated to withstand a 1700° fire.

Triple wall chimney  
with air space  
(end view)

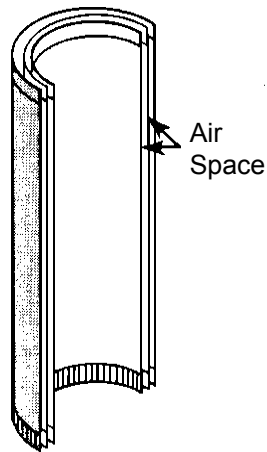

Double wall chimney  
with insulation  
(end view)

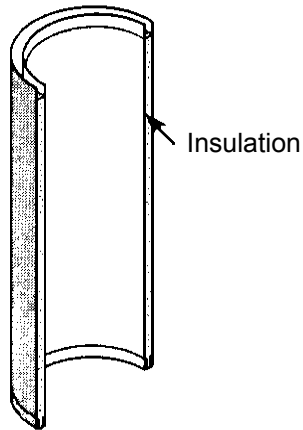

## CHIMNEYS CONTINUED

**Chimneys must extend upward at least 3 feet above the roof line!** To insure proper drafting, the chimney must be 2 feet higher at the point where any nearby structure comes within 10 feet.

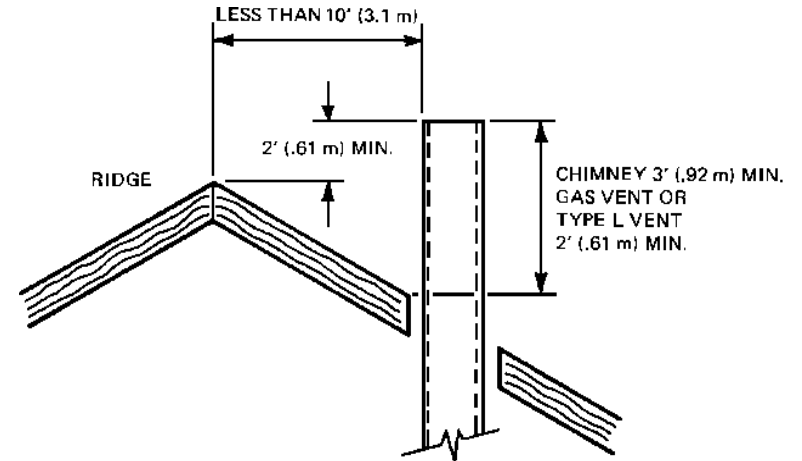

## CHIMNEY CAPS OR SPARK ARRESTORS

A chimney cap is recommended to prevent problems with sparks and debris exiting the chimney. This also prevents birds from building nests inside the chimney.

## DOUBLE VENTING CONCERNS

**It is not acceptable for a solid fuel heating appliance to share a flue with a conventional heating appliance. Below is a list of reasons why the practice is prohibited.**

1. Different fuels produce dissimilar by-products of combustion. These can be highly corrosive to flue liners.
2. In the event of a flue fire, the damper on a solid fuel appliance may be closed, thus shutting off the supply of oxygen to the fire. Conventional heating appliances are drafting constantly and thus have no way to shut off oxygen.
3. The capacity of the chimney must be large enough to serve all appliances operating at once, yet be able to serve a single appliance.
4. Creosote accumulation in the flue can restrict or stop the flow of combustion by-products up the flue.
5. An undersized flue can force toxic gases into living areas and asphyxiation can occur.
6. If a gas appliance should fail, such as when a pilot light goes out, gas can be released into the flue and be ignited by a wood spark.

## FIREPLACES

Fireplaces create a warm, friendly atmosphere but can become dangerous if proper precautions are not taken. Recent purchasers of homes containing fireplaces should have these inspected for safety and soundness.

Zero clearance fireplaces are becoming increasingly popular. These are made of pre-fabricated metal and are designed to be installed with minimal clearances to combustibles. The fireplace and chimney must be UL listed and is manufactured as one unit. This assembly is tested as one unit and must not be interchanged with that of another manufacturer.

A protective screen should be placed in front of the fireplace to prevent sparks from escaping. The hearth should extend to 16" in front of the fireplace. It is recommended that a non-combustible hearth rug should be placed on the floor in front of the fireplace.

## FIREPLACE INSERTS

Masonry fireplaces were designed to operate without any additional apparatus attached. To enhance the heat output of a masonry fireplace, inserts have become increasingly popular. An insert is actually a separate stove placed in side a masonry fireplace. These can be used safely if installed properly.

The hearth should extend out at least 18 inches in front of the doors of the insert. As an alternative, the hearth may be extended outward by the use of a "UL listed" hearth board or non-combustible floor surface such as stone or bricks. The use of inserts in zero clearance fireplaces is not acceptable and very dangerous.

**Fireplace inserts must have a direct positive connection.** This positive connection is created by installing a flue connector pipe extending from the insert into the chimney. This pipe should extend beyond the smoke shelf to the top of the chimney. If the insert to chimney connector ends in the smoke shelf area, proper drafting does not occur, creosote may build, and toxic gases may downdraft into the living area.

**To assure a positive connection, the fireplace insert must be professional installed.**

## FIREPLACE INSERTS CONTINUED

### CLEARANCE REQUIREMENTS FOR INSERTS

The same clearance rules apply for inserts as for woodburning stoves.

### CLEARANCE TO COMBUSTIBLES

Front and sides of insert	36 inches
Top of insert to mantel	36 inches*

### HEARTH EXTENSION

Front to face of insert	18 inches
Sides to side of insert	18 inches*

\* If you have a UL "LISTED" fireplace insert, the clearances might be different. Refer to the instruction manual or the listing label for these specific clearances.

### DIRECT POSITIVE CONNECTION

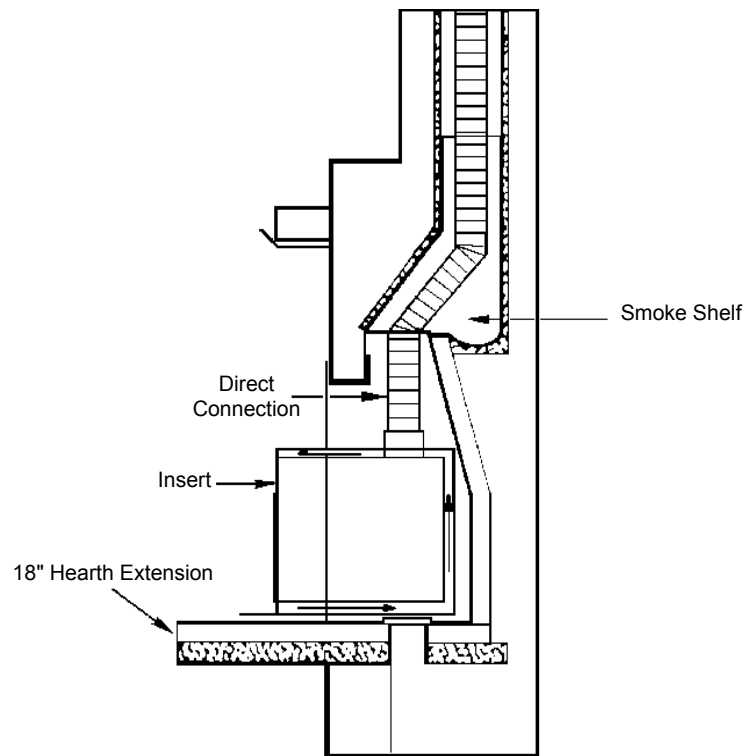

11

## OUTDOOR WOOD HEAT

Outdoor wood heating systems are acceptable and can be used safely if certain guidelines are followed.

First and foremost, the system must be a hot-water type system. Forced air systems should not be used! This system should be installed and inspected by a licensed plumbing and heating contractor.

The building should be at least 40 feet from the dwelling and built on a solid, non-combustible floor.

The outside door should face away from the dwelling to prevent sparks from blowing back towards the house.

Preferably the building itself should be made of non-combustible material.

Wood should not be stored inside of the building because of the danger of igniting.

Wood should not be stored too close to the woodburning unit as sparks from the unit may ignite the wood pile.

The woodburning unit should contain proper relief valves, pop-off valves, and water expansion tank. Many times anti-freeze is used in the system to prevent freezing and bursting. In most instances, the hot water pipes leading from the woodburning unit to the dwelling are surrounded by styrofoam insulation. Most wood heating systems require a Class A chimney.

New Wood Boilers require a 6" clearance to the back and sides. The front of the Boiler needs 48" clearance.

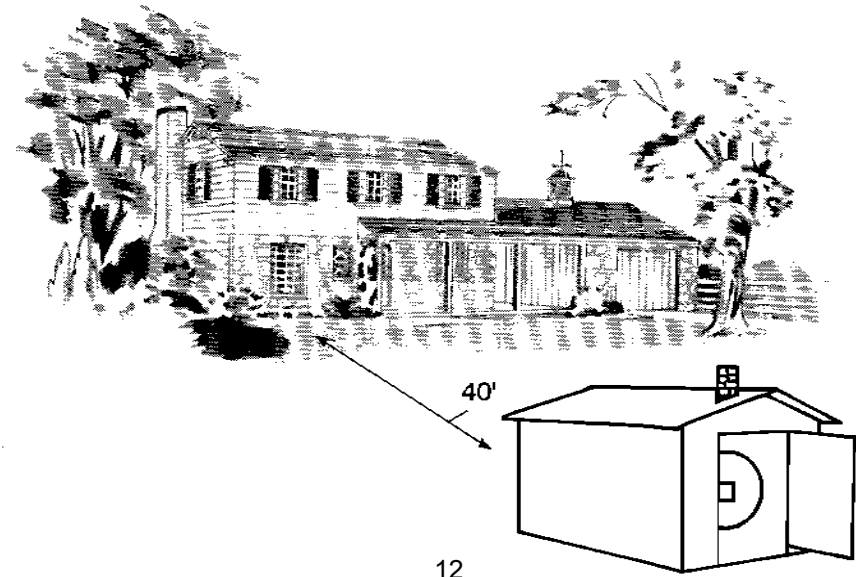

12

## RECOMMENDATIONS FOR SAFE WOODBURNING

### 1. FIRE EXTINGUISHERS

- a. An ABC type fire extinguisher, with a minimum rating of 2A 10BC, is recommended in dwellings and outbuildings containing woodburning equipment.
- b. Chimney fires may be controlled using specially constructed extinguishers, such as the "Chimfex" extinguisher. These are used by removing the cap, striking the end like a match and closing it inside the stove.

### 2. SMOKE DETECTORS

Every dwelling unit within a dwelling must be provided with a smoke detector meeting the requirement of the State Fire Code as well as one placed on each level of the dwelling and tested regularly.

### 3. CARBON MONOXIDE ALARMS

Every single family dwelling and every dwelling unit should have an approved and operational carbon monoxide alarm installed within ten feet of each room lawfully used for sleeping purposes.

### 4. STOVE PIPE TEMPERATURE GAUGES AND ALARM SYSTEMS

These two devices monitor the temperature of the stove pipe to warn of dangerously high temperatures being produced.

### 5. AVOID CREOSOTE BUILDUP

- a. Burn dry, well seasoned wood. Wood should be stored about 9 months so that it is good and dry.
- b. Don't over fire or under fire the system. Never overload the stove with wood but build a hot enough fire (about 350°F) so that creosote will not accumulate.
- c. Do not burn trash or paper in a woodburning unit as burning particles may land on the dwelling and ignite it.
- d. Check the system monthly and clean it when creosote begins to accumulate.
- e. Proper cleaning brushes should be used to clean the chimney. Never use chains or other similar items as these may damage the liner.

### 6. ASH DISPOSAL

Ashes should be placed in a metal container with a tight fitting cover. This container should not be set on a combustible floor. Hot or warm ashes should be kept outside away from the dwelling to cool.

## 7. UNSAFE PRACTICES

- a. Do not use a woodburner to burn trash as woodburners are not designed to withstand the high heat generated by paper and other similar products.
- b. Do not start a fire using flammable liquid!!!
- c. Never leave a burning wood stove unattended. A large number of lives are lost when a fireplace or woodburning unit is left burning overnight!!!

## CHARACTERISTICS OF WOOD

Tree Species	Coaling Qualities	Sparks
Apple	Excellent	Few
Oak (red)	Excellent	Few
Maple (sugar)	Excellent	Few
Locusts (black)	Excellent	Few
Cherry	Excellent	Few
Hickory	Excellent	Moderate
Elm	Good	Very Few
Ash	Good	Few
Beech	Good	Few
Birch (white)	Good	Moderate
Cottonwood	Poor	Moderate
Pine	Poor	Moderate
Cedar	Poor	Many
Hemlock	Low	Many

Pine, cedar and other soft woods should not be used because of the high levels of creosote they produce.





Portions of this brochure have been reprinted from "NFPA211-1988 Chimneys, Fireplaces, Vents, and Solid Fuel Burning Appliances", Copyright 1988, with the permission of the National Fire Protection Association, Quincy, Massachusetts 02269. North Star Mutual Insurance Company does not make any warranty, guarantee or representation as to whether any representation is absolutely correct or sufficient. No responsibility is assumed by North Star and it cannot be assumed that all acceptable safety measures are listed herein. Under certain circumstances, additional measures may be required for safe installation and operation.