

# Knob & Tube Wiring by Douglas Hansen

**K**nob & Tube wiring was a system of open conductors supported on ceramic knobs. It also used ceramic tubes where wires cross each other or pass through framing. Like most old electrical systems, it is likely to have been damaged or altered over time, and home inspectors often must recommend it be repaired or further evaluated by a qualified electrical contractor.

## The Good Points...

The theoretical advantage of knob & tube wiring is that it dissipates heat into free air, and therefore has a higher ampacity than cable systems with equivalent wire size. In many older systems the use of 25 amp fuses corresponded with the higher ampacity of this wire. The insulation used on some knob & tube wiring was rated for high temperatures.

Because the wires are held away from the framing, it is less likely to be punctured by nails as compared to Romex® (non-metallic sheathed cable).

A high degree of skill was needed to install knob & tube wiring. The necessary drilling, splicing, soldering, and wrapping were all items that required specialized training. Modern wiring systems, such as Romex®, do not require such training, and are often installed by unskilled persons. The problems we find with knob & tube are not so much with the original installation as with the subsequent alterations. Problems like those in figure 2 are rare.

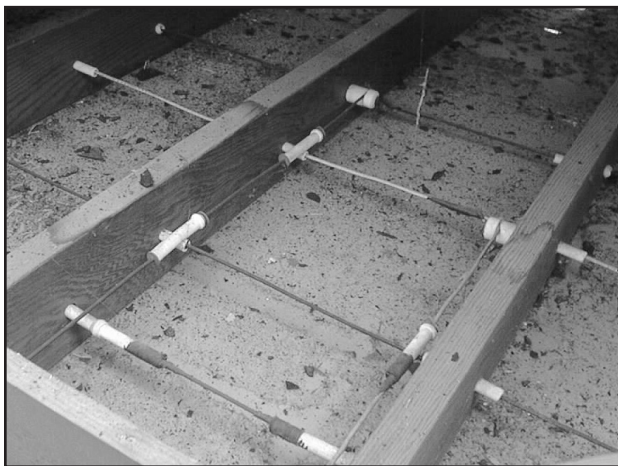

Figure 1 — Undamaged Knob and Tube System

Not all knob-and-tube is old. In some communities, knob & tube wiring with thermoplastic insulation was installed well

into the 1960's. However, the chances of finding a pristine system, such as in Figure 1, grow less likely each day.

## And the Bad...

Alterations of knob & tube wiring are almost inevitable. The ever increasing demand on electrical systems makes it very likely that an older system will be tapped, usually by unskilled persons, and the system may have been dangerously overfused at some point in its history. Moisture, heat, and thermal insulation might also damage the knob and tube.

Older systems might be insulated with rubber, varnished cambric (fiber), or asbestos. "Rubber" insulation is a mixture of ingredients including vulcanizing agents, anti-oxidants, pigments, fillers, and softeners. The various additives oxidize copper wire, so the wires must be coated with tin, lead, or nickel. The coatings have a soft gray color on the surface. Inspectors should not confuse this gray coating with aluminum wire, which was not used on small conductors until after the days of knob & tube.

Cambric and asbestos insulation types are not rated for exposure to moisture, and the wiring can be damaged by roof leaks. The insulating materials usually become brittle with heat and age and may break down, sometimes leaving the wiring with a dangerous lack of protection. The wiring also tends to stretch and sag over time.

Knob & tube wiring is very vulnerable to mechanical damage, such as from items stored in an attic. Bending the wire can cause older insulation to crumble and fall off the wires.

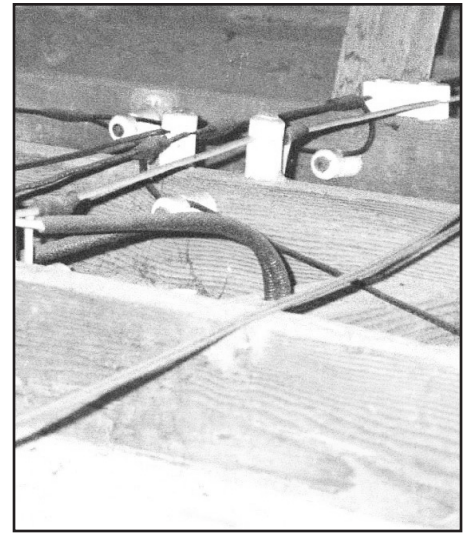

Figure 2 — Example of Improper Installation - Placement on top of joists rather than sides, insufficient clearance to structure, insufficient conductor separation, and lack of protection where wires cross

## Installation Requirements

The tubes that protect wires crossing over each other should be taped in place. Porcelain tubes should also be installed where wires run over or under pipes. Tubes passing horizontally through joists should be slightly angled, with the head of the tube on the uphill side to prevent them from slipping out of joists. The wiring should clear the ceiling material and framing by at least one inch, and parallel wires should have 3 inches separation. The knobs should be nailed to the sides of ceiling joists, not the tops of the joists. Knobs are also acceptable on the tops of wall plates. Knobs should be placed no further than 6 inches from a splice, and not further apart than 4½ feet. Protective “loom” should cover the wire from the last knob to each outlet box or panel.

Exposed splices are allowed in the original knob and tube. Wires are wrapped around each other in a “telegraph splice” and then soldered. A final wrapping of tape covers the splice (typically a type of friction tape that preceded plastic electrical tape). Often the framing near the splices will be blackened from the torch the electrician used in soldering the wire. These blackened spots should not be confused with burning or overheating of the wiring system.

Concealed knob & tube wiring is not allowed in new installations since the 1975 NEC®, though the NEC® does allow existing systems to remain in place and to be extended with other wiring methods, such as NM cable.

## Splicing the Old to the New

Splices from knob & tube to another wiring method are often done incorrectly. Even though the original knob & tube splices are exposed, splices to another wiring method must be contained in boxes. Because wires entering a box must

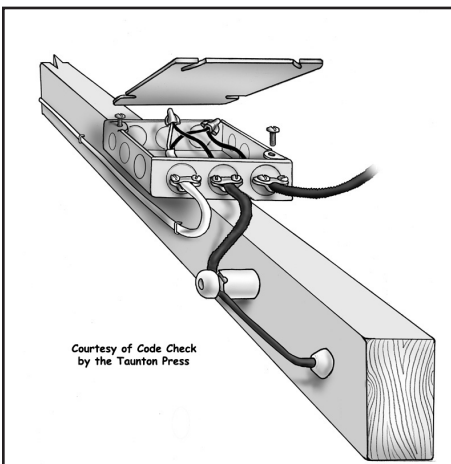

Figure 3 — Proper Splicing Method for Extensions

have at least 6 inches of free conductor in the box, a single box is seldom sufficient; two boxes are usually needed.

An A-head device with a bushing is needed at the end of an AC cable before splicing to knob and tube, and loom should cover each con-

ductor of the knob and tube between the last knob and the device. The conductors from the AC cable should only extend as far as necessary to have an open splice into the knob & tube. Due to the lack of availability of older loom, some jurisdictions allow a piece of Romex® sheathing as a substitute for loom. In most instances, splices are improper and should be avoided. New circuits are usually a better choice instead of extending the older wiring system.

## Thermal Insulation

Knob & tube wiring is designed to dissipate heat to free air. The NEC® requires that attics and walls with this type of wiring not be insulated in such a manner that the insulation envelops the wire. However, the California Electrical Code has amended section 324-4 to allow insulation in contact with knob & tube provided 6 conditions are met. These are:

1. A licensed electrical contractor must inspect the wiring and certify that it is safe. Any unsafe conditions, such as improper splicing or overfusing, must be corrected. All corrective work must be done with proper permits.
2. The certification must be filed with the local building department, and a copy furnished to the property owner.



Figure 4 — Warning Sign

3. Accessible areas where insulation has been installed over the wiring must be posted with a warning sign (figure 4). In some jurisdictions, the sign must be in Spanish and English.



Figure 5 - Paper Faced Insulation

4. The insulation must be non-combustible. Paper-backed fiberglass (figure 5) would not qualify.
5. The insulation must be non-conductive. Foil-faced fiberglass (figure 6) would not qualify.



Figure 6 — Foil-Faced Insulation

insulation are treated with materials to inhibit flame spread. Some materials, including loose cellulose, have failed flame-spread tests after they were installed. Cellulose insulation (figure 7) is made of ground-up newsprint and a fireproofing chemical (usually a borate) mixed dry. It is possible the chemicals settle out of the insulation, reducing its fire resistance. Loose fiberglass does not have the same concerns regarding flammability.

6. Normal permit requirements for insulation still apply.

The insulation must meet standards of fire resistance per section 215.2 of Part 2 of Title 24. Even materials such as “Palco Wool” (redwood shavings) or crepe-type paper

Additional hazards may be present if the walls have been insulated. Packing the insulation material around the knob & tube could damage the wiring in a concealed space.

## Reporting

Almost inevitably, other problems will be found when knob & tube wiring is present. Even if the system appears to be in pristine condition, there is a high likelihood that a recommendation will be made to refer to a qualified electrical contractor. If no thermal insulation is present, that by itself will be a concern to the client because of energy issues, and when installed, thermal insulation must comply with the California amendments to the NEC®. ❖



Figure 7 — Non-Flammable Insulation