



Installing Manufactured Homes *in Skagit County*

This handout will help you to install your manufactured home. Every manufactured home installer except the homeowner must be certified by the State of Washington.



Manufacturers publish installation standards for the homes they build. These are the instructions to follow when installing a manufactured home. Used manufactured homes whose installation instructions have been lost shall be installed according to Federal Government Standards ANSI A225.1 for Manufactured Home Installation. This handout uses ANSI Standards, Skagit County policies and

ordinances and in some cases, the Uniform Building Code.

In a number of places, this handout will refer you to a drawing or requirement that is found in another part of the handout. It is important for you to look at the references.

If you have circumstances not covered in this handout, you may contact a plans examiner or building inspector at our office (360) 336-9410.

Index

- A. Site requirements.
- B. The foundation and support system.
- C. Foundations in the floodplain.
- D. Anchoring the home.
- E. Plumbing and mechanical systems.
- F. Skirting and ventilation.
- G. Decks, landings, stairs, etc.
- H. Inspections.

A. Site requirements.

1. Skagit County Code 14.32 contains drainage regulations that went into effect in July, 2000. The complete code is available on the Skagit County website http://www.skagitcounty.net/offices/planning_and_permit/index.htm. Even small projects have drainage requirements.
 - a. If the combined area of roofs, porches, concrete patios and your driveway add up to 5000 square feet or more, your project will require an engineered drainage plan. Please contact our department staff first.
 - b. Cover all exposed soil with polyethylene or straw until you are ready for final grading. The building inspector will inspect the erosion control at the first inspection. If you want to use a different method, contact this department for more information and help.
 - c. After final grading, exposed soil should be replanted with grass, shrubs, trees, etc.
2. Manufacturers assume the soil bearing capacity where the home will be installed is at least 1500 pounds per square foot, common in most of Skagit County. If you are unsure the soil is suitable, contact our department or have the soil bearing capacity tested by a testing lab.
3. The home must be installed on a level site. Slopes or step-downs are not allowed unless you have a specific design from an engineer.
4. All organic materials like grass, weeds, tree roots, etc. must to be removed to remove food for pests, prevent organic decay and support the home on firm, undisturbed soil.
5. Fill more than 12 inches deep must be compacted and tested when it is used to support the home. Give a copy of the compaction report from a WABO approved agency to the building inspector at your first inspection. You can call us to find out which labs are approved or look in the Yellow Pages under Testing Labs. It's a good idea to contact the testing agency before you bring in the fill so they can help you plan to place, compact and test it.
6. If your site is in a designated floodplain, Skagit County Code 14.34.140 (6) prohibits fill as a means to elevate your home. You must support it and elevate it some other way. There is one exception to this: if a professional engineer calculates that there will not be any effect on the floodplain, that flood waters will not be diverted to another location, or that the ability to store flood waters is not reduced, then you may be able to use structural fill. If you want to use this exception, you should contact an engineer before making any plans that would include it.

B. The Foundation and Support System.

If your site is in a floodplain, section "C" will also apply.

The examples are based on the following information and building dimensions. If any of your building dimensions are less than the minimums or more than the maximums, you will must check with this department, the ANSI standards or your manufacturers requirements for any changes that are needed.

1. The maximum home section width is 14 feet. Same for single wide.
2. The maximum roof live load is 30 pounds per square foot for this foundation setup, which will work in most of the county. Areas east of Concrete have higher snow loads. Contact this department for the east-County areas.
3. The maximum mating wall opening is 15 feet. This is the opening in the marriage wall for living and dining rooms.
4. The maximum pier spacing 10 feet.
5. The minimum footing size 20" x 20" x 4".

Minimum construction requirements:

1. The concrete pad, or footing, must be placed on firm and level ground.
2. The support piers must be 8" x 8" x 16" concrete blocks and placed as follows:

- There must be at least 12 inches of clearance from the bottom of the steel beam to the ground.
- If the support piers are 3 feet high or less, you can use a single stack. See Fig. 1.
- If they are over 3 feet but less than 7½ feet high, they must be double-stacked with interlocking stacks. See Fig. 2.
- If they are over 7½ feet high, they must be designed by a professional engineer.
- They must be placed under the steel beams, not more than 10 feet apart and so that there is a pier within 2 feet of the end of each beam.
- They also must be placed under each side of every exterior door, under each side of windows that are more than 4 feet wide and under bearing points of the mating wall opening. See Figure 3 below.
- The piers must have a top cap, which can be wood (2" x 8" x 16") or solid concrete (4" x 8" x 16").

3. The gap between the pier cap and the steel beam can be filled with wood that is not more than 2x material. See Figures 1 & 2.
4. The wood shims used to level the home must be 4 to 6 inches long and a maximum of 1½ inches thick. See Figures 1 & 2.

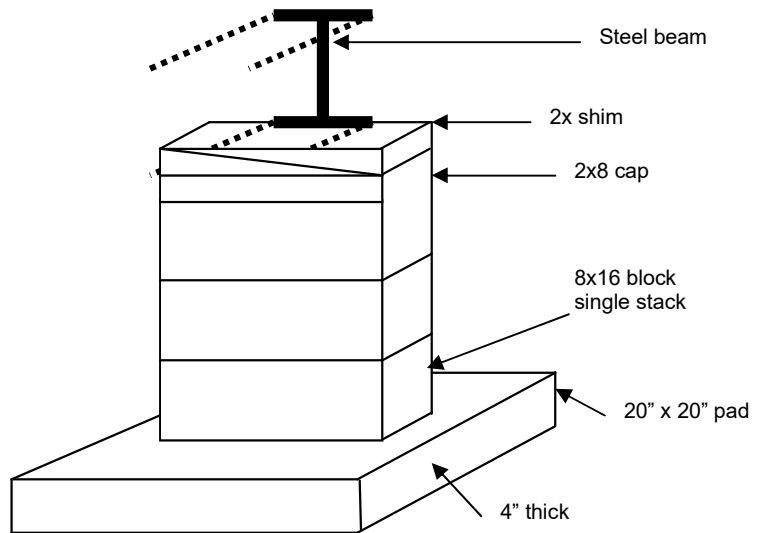

Figure 1

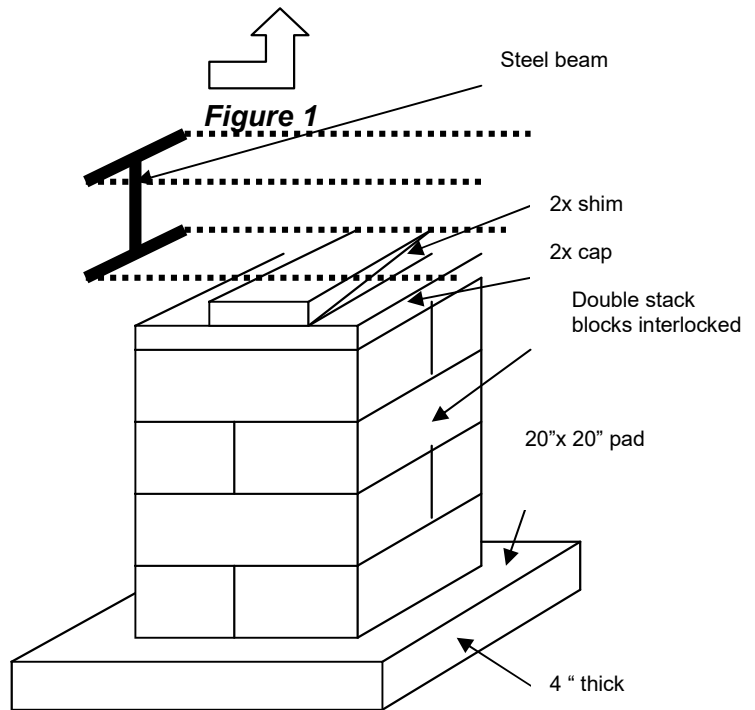
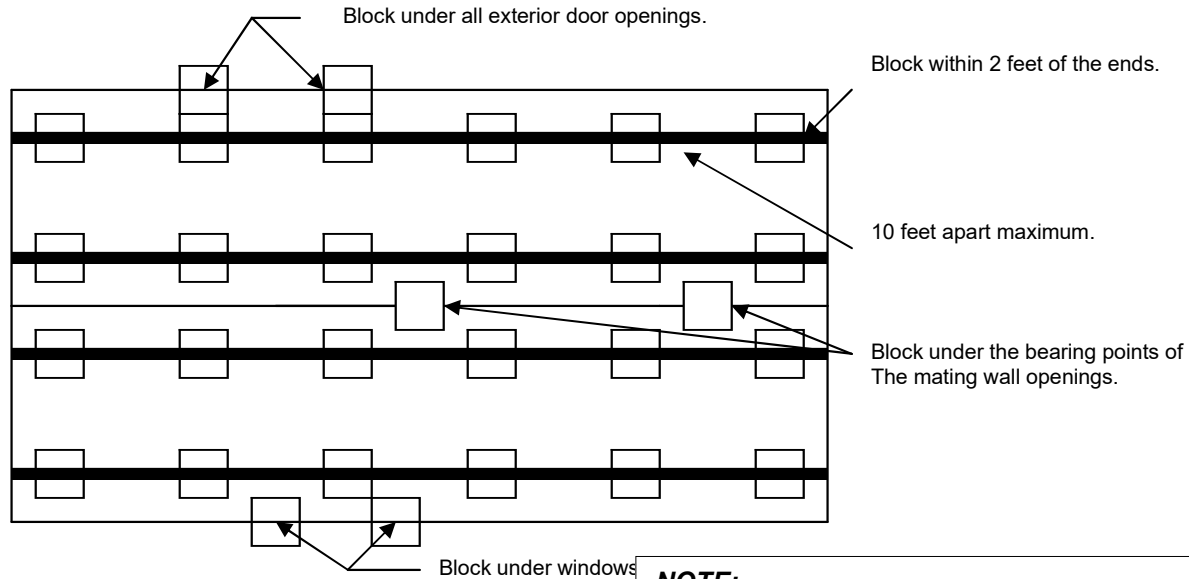

Figure 2

Double-wide pad and blocking locations.



NOTE:

1. Single wide homes can use the example above.
2. All blocking locations are the same on a single wide home except that there will not a mating wall opening in the center.

Figure 3



C. Foundations in the Floodplain.

Most of the information and dimensions in section B above apply to homes in the floodplain, but in the flood plain foundations must be permanent. Dry stacked blocks are not considered as a permanent foundation. The ANSI standards and manufacturer requirements generally ignore floodplain installations. Here's what this department considers a permanent foundation. There are engineered products that are also acceptable.

The whole concrete pad, or footing, must be placed so that it is 12" below pre-development grade. You may trench the footings or foundation into the ground or fill around concrete poured 12" below pre-development grade.

Instead of just stacking the blocks, you must cement them to the ribbons or slab and to each other so that they are one permanent support. There are a couple of options for doing this:

- a. You can mortar all of the head and bed joints to each other and to the concrete ribbons or slab. See Figure 6 below.
 - b. You can stub steel rebar into the concrete, place the blocks over the rebar and fill the empty cells with grout. See Figure 4 below.
 - c. There are engineered products that bolt to the concrete and to the steel beam that may replace some of the blocks. Manufactured home dealers sell these products.
4. All other information from Item B above applies to flood plain foundations.

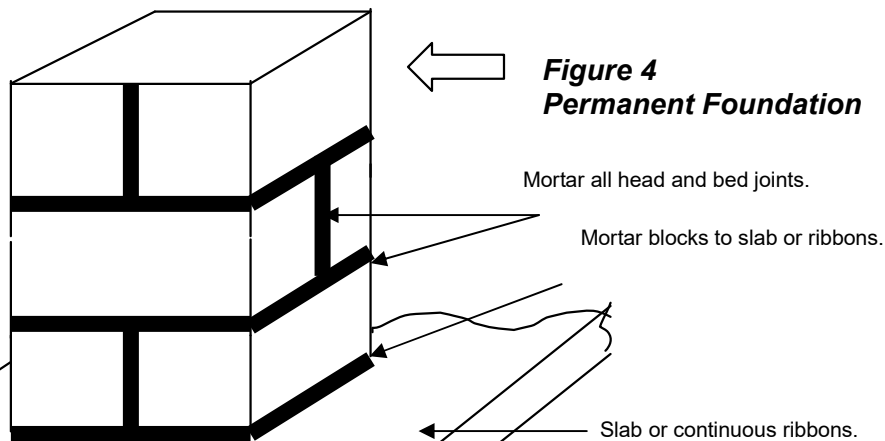

Figure 4
Permanent Foundation

D. Anchoring the home.

Tie-down assemblies are required on all manufactured homes for resistance to high winds. The system that you choose must anchor the frame to the ground.

Spacing of tie-down assemblies:

- The maximum space between assemblies is 11 feet unless your manufacturer requires a closer spacing. See Figure 5.
- There must be a tie-down assembly within 2 feet of each end of each section.

NOTE: Double and single wide tie-down locations. Locations are approximate, not exact.

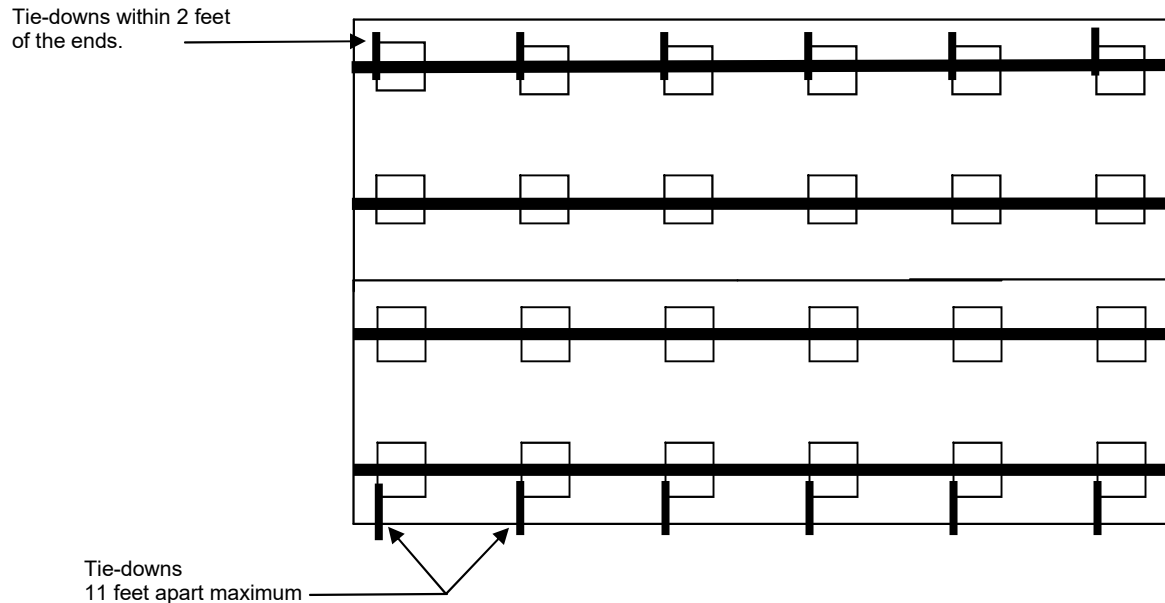

Figure 5

Anchors.

1. If you choose a ground (auger-type) anchor, it must be installed according to the manufacturer's requirements and its listing. See Figure 6 below.

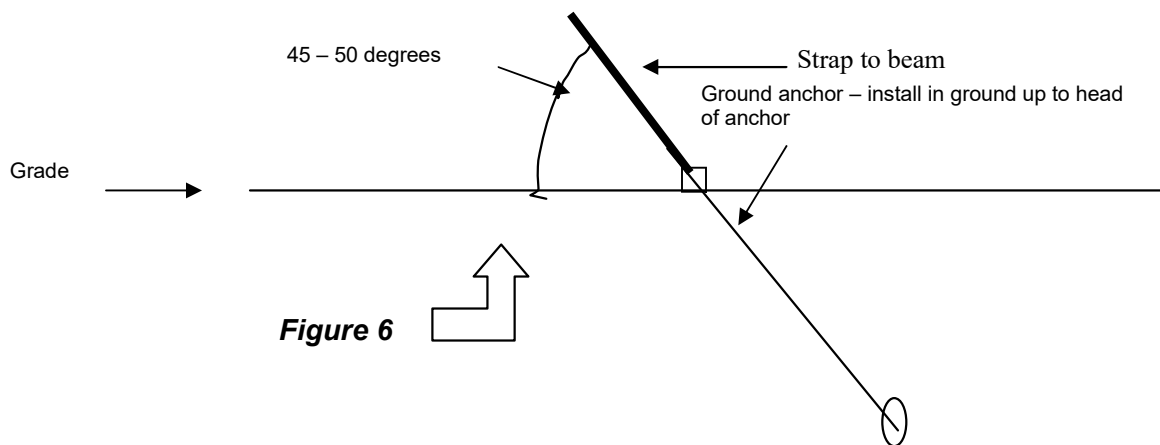

Figure 6

2. If you are placing steel rods in the concrete slab or ribbons, there must be enough of the steel rod in the concrete to provide the required strength. See Figure 7 below.

Steel rod set in concrete

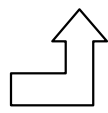
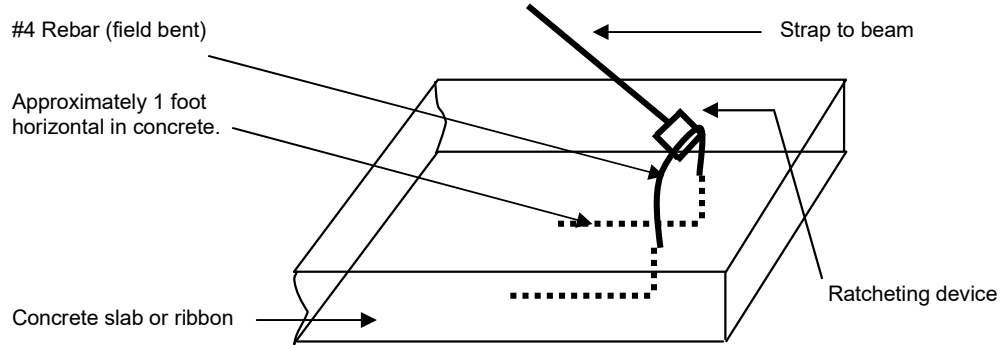

Figure 7

Connecting the frame to the anchor.

If you use a cable system, you must provide a 5/8-inch closed-loop eyebolt through the center of the frame web; the cable must be at least 1/4-inch; there must be 2 cable clamps and a turnbuckle at each end of the cable. Use the turnbuckles to remove all slack from the cable. See Figure 8 below.

Cable system

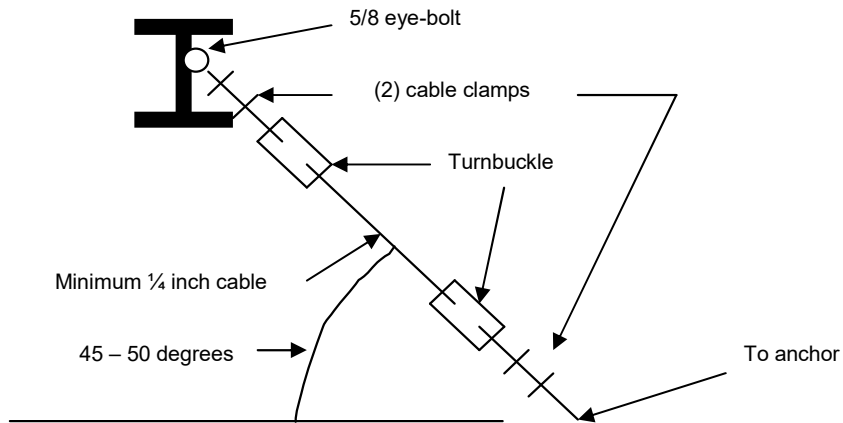
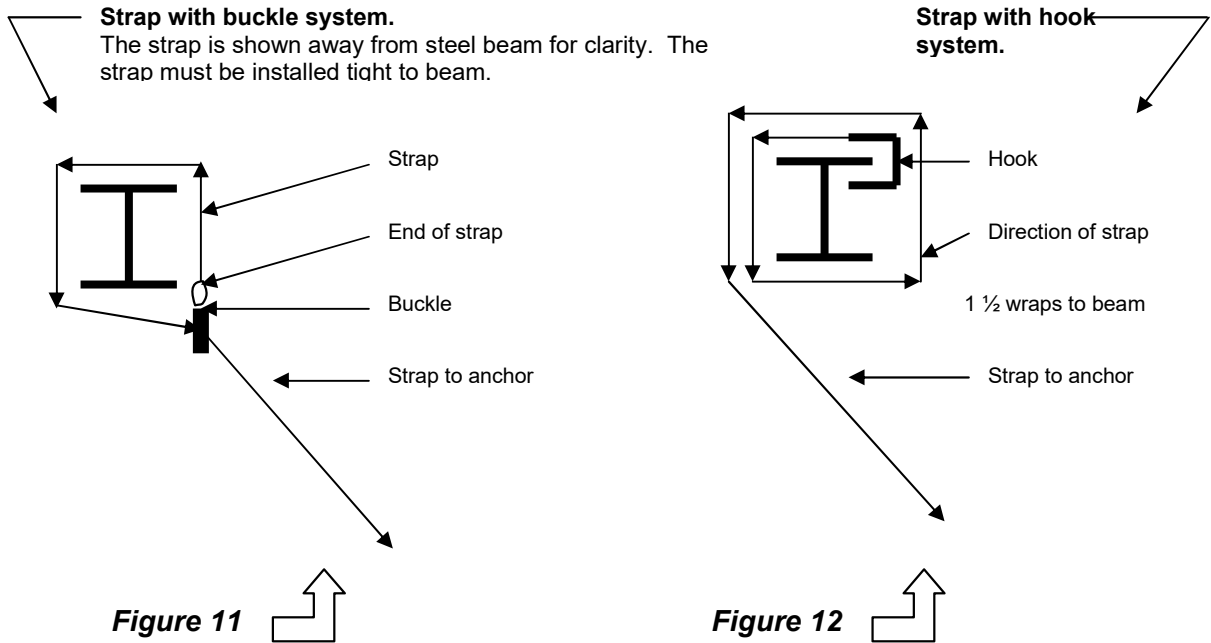

Figure 8

If you are using a strap system, it must be installed according to all of the manufacturer's requirements. This includes having the buckle or the hook in the correct location on the frame. See Figure 11 and 12 below.



E. Plumbing and Mechanical Systems.

1. New water supply piping must be tested to hold 50-psi pressure before hook-up to service. The building inspector or a certified installer must inspect this test.
2. The new supply piping must have an accessible shut-off valve at the point where it connects to the piping installed in the home.
3. Any sections of the supply piping that are exposed to freezing temperatures must be insulated.
4. The waste line must be adequately supported to carry the weight of the water-filled line must and have a slope of ¼-inch of drop for 1 foot of run. The slope can be reduced to 1/8-inch per foot if you provide a cleanout at the upper end of the run.
5. The plumbing waste line must be tested by capping the line and filling it with water before final hook-up. The building inspector or a certified installer must verify this test.
6. Piping for propane or natural gas must be adequately supported and must be pressure-tested at 15 psi before hook-up to the source. The building inspector or a certified installer must do this.
7. The heat ducts must be supported and elevated so that they are not in contact with the ground.
8. The pressure relief line from the hot water tank and the dryer vent must be run so that they come out through the skirting. The dryer vent must have a back draft damper on it where it comes through the skirting. The pressure relief line and the condensate line need a turndown fitting so that they point to the ground.
9. The dryer vent line must be a smooth-wall metal duct (extending through the wall, terminating to an outside wall). The joints must be taped (screws are not allowed). A plastic flex duct is only allowed to connect the dryer to the metal duct at the wall.

F. Skirting and ventilation.

Skirting is required around the entire perimeter on all manufactured homes. It must extend down to the soil. There is no particular material required for skirting (except in some cities), but the following requirements apply to all skirting.

- a. Any wood used within 6 inches of soil has to be pressure-treated or naturally resistant to decay, such as cedar.
- b. There must be an access opening of 18"x 24" with a tight-fitting door.
- c. Ventilation openings must be at least equal to 1 square foot of opening for every 150 square feet of floor area of the home. The openings must have ¼-inch mesh screen, and they must be evenly spaced so that there is good airflow through the under floor area.

Exception: If you have a full slab, you can provide 1 foot of opening for every 300 square feet of floor area.

Example: With a home of 1500 square feet, there would be 10 square feet of vent openings required.

If using vents that are 6" x 12" (1/2 sq. ft.), you would need 20 vents, equally spaced around the home. You would need ten of those vents if you had a full slab.

- d. Floodplain vents. If your home is in a floodplain, the vents mentioned in the third item above must be located so that the bottom edge of the vent is no more than 12 inches above the ground. This is to allow floodwaters to get in and get back out.

A 6 mil. black plastic moisture barrier must be installed on the ground surface under the home unless there is a full slab under the home.

G. Decks, Landings, Stairs, etc.

Landings and stairs are required with the manufactured home and do not require a separate permit. Decks up to 125 square feet are also included in the cost of the building permit. Decks that are more than 30" above grade and more than 125 square feet will need construction plans and a permit. The following requirements apply to all homes.

1. There must be a landing outside of every exterior door. The minimum size of landing is 36"x 36" and must be within 1 inch of the door threshold if the door swings out. You are allowed to build the landing one step down from the door provided the door swings in. A step has at least 4 inches and at most 8 inches of rise.
2. Any landing or deck that is over 30 inches above the ground must have a guardrail. The guardrail must be at least 36 inches high. The intermediate (or upright) rails must be spaced so that a 4-inch sphere cannot pass through.
3. The stairs must be at least 36 inches wide. The depth of the tread (or run) must be at least 9 inches. The height (or rise) must be at least 4 inches but cannot be more than 8 inches. The rise of any stair cannot vary more than 3/8-inch from any other stair.
4. If there are more than three steps, a guardrail must be placed on each open side. The requirements are the same as for the guardrail described above.
5. If there are more than three steps, a handrail is required on at least one side. The handrail must be 1 ¼ – 2 inches across and it must be graspable, meaning that a person can get their hand around it. Using 2x4's and 2x6's that are flat or on edge are not considered graspable and are not allowed as a handrail. The handrail must be placed between 34 inches and 38 inches high measuring from the leading edge of the step. Handrails must be continuous from the top step to the bottom step.
6. Deck construction plans must be provided with the building permit application. The plans must show the size, grade, species, spacing and connections of all framing members.
7. Structural deck and stair members (beams, posts and joists) that are exposed to weather must be pressure-treated or of natural resistance to decay (such as cedar). Nails and screws must be corrosion resistant.

H. Inspections.

The following inspections are typical for manufactured homes:

1. Tie-down and blocking inspection. This is usually the first inspection and should be requested when the home is in place, the blocks are in place, the tie-downs are installed and the plumbing and mechanical systems are installed. That would cover all of the items in sections A through D and all but the last two items in section E. This inspection should take place before the skirting is put on. Erosion control will be inspected. *The FEMA elevation certificate is required at this time if your home is in the floodplain.*
2. Skirting inspection. This inspection should be requested when the items in section F and the last two items in section E are completed.
3. Final inspection. This inspection should be requested when all of the landings and stairs are in, when decks are complete, when final grading is complete, when the address is posted and when any other permit requirements (if there are any) have been completed.
4. The skirting inspection and the final inspection may be combined into one inspection if all items have been completed.