

SPOT VENTILATION

Source control to improve indoor air quality



Buildings for the 21st Century

Buildings that are more energy efficient, comfortable, and affordable...that's the goal of DOE's Building Technologies Program.

To accelerate the development and wide application of energy efficiency measures, the Building Technologies Program:

- Conducts R&D on technologies and concepts for energy efficiency, working closely with the building industry and with manufacturers of materials, equipment, and appliances
- Promotes energy/money saving opportunities to both builders and buyers of homes and commercial buildings
- Works with state and local regulatory groups to improve building codes, appliance standards, and guidelines for efficient energy use

PURPOSE OF VENTILATION

All homes need ventilation—the exchange of indoor air with outdoor air—to reduce indoor moisture, odors, and other pollutants.

Contaminants such as formaldehyde, volatile organic compounds (VOCs), and radon that may cause health problems can accumulate in poorly ventilated homes. Inadequate ventilation prevents unpleasant odors from being removed. Excess moisture generated within the home needs to be removed before high humidity levels lead to physical damage to the home or mold growth.

VENTILATION STRATEGIES

Ventilation techniques and strategies have become more sophisticated as homes have become more complex. The American Society of Heating, Refrigerating and Air-Conditioning Engineers, Inc. (ASHRAE) requires that natural, or natural plus mechanical, ventilation provide a whole-house ventilation rate of 0.35 air changes per hour (ACH), but not less than 15 cubic feet per minute (cfm) per person.

Natural ventilation—uncontrolled air movement into a building through cracks and small holes (infiltration) and through vents such as windows and doors—is the traditional method of allowing fresh outdoor air to replace indoor air. Nowadays, because of central heating and cooling, as well as the desire for privacy, people tend to make little use of windows for ventilation, so infiltration has become the principal mode of natural ventilation in homes. Unfortunately, a home's natural infiltration rate is unpredictable and uncontrollable because it depends on the home's airtightness, outdoor temperatures, wind, and other factors. Homes with low infiltration rates may lack sufficient ventilation for pollutant removal. Homes with high infiltration rates may experience high energy costs. Also, infiltration may allow contaminated air to enter from a polluted area

INDOOR AIR POLLUTION SOURCES

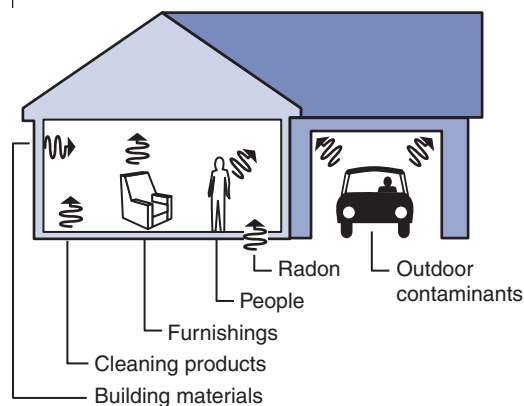

such as a garage or crawlspace, or may not ventilate the house uniformly.

Whole-house ventilation—use of one or more fans and duct systems to exhaust stale air and/or supply fresh air to the house—can better control the exchange of indoor air with outdoor air. Whole-house ventilation may be exhaust-only (relying on leakage into the building for fresh make-up air), supply-only (relying on air leakage from the building to exhaust stale air), or balanced systems that include both exhaust and fresh air intake components.

Spot ventilation—the use of localized exhaust fans (e.g., kitchen and bath fans) to quickly remove pollutants at their source as they are generated—is an important tool to improve air quality and ventilation effectiveness whether natural or whole-house ventilation strategies are used. Spot ventilation strategies are often integrated with whole-house ventilation designs. In addition to its whole-house ventilation requirement, ASHRAE recommends intermittent or continuous ventilation rates for bathrooms and kitchens as alternatives to operable windows: 50 or 20 cfm for bathrooms and 100 or 25 cfm for kitchens, respectively.



SPOT VENTILATION DESIGN

Building codes may provide specific requirements concerning spot ventilation. Generally, the guidelines in this fact sheet meet or exceed code requirements; however, it is important to consult local codes and code officials before sizing and installing spot ventilation systems.

Spot ventilation is recommended for bathrooms and kitchen ranges. Bathroom windows are seldom opened in cold or hot weather. Recirculating range hoods do not remove cooking-generated moisture from the living space and are not generally effective at controlling odors. Therefore, these are considered poor substitutes for directly exhausting polluted air from these locations to the outside.

Spot ventilation fans are intended to reduce concentrations of moisture or pollutants in the living space. Inevitably, they exhaust clean room air along with the moist or polluted air. To maximize effectiveness,

- Exhaust fans should be located as close as possible to the sources of moisture or pollutants. In the kitchen, range hoods that exhaust to the outside are preferable to kitchen vent fans because most kitchen moisture and pollution come from the range. Hood-mounted range fans are also preferable to surface-mounted downdraft cooktop vents. Although surface-mounted vents are located close to the source of the pollution, they are less effective than hood-mounted fans because the downdraft design must overcome the buoyancy of warm, polluted air coming from the cooking surface.
- Space heating and cooling registers should be located as far as practical from exhaust vents to minimize the amount of conditioned air that is directly exhausted with the polluted air.
- Automatic or manual controls should be installed to allow the fan to operate only when needed.

Spot ventilation exhaust fans produce noise that can disrupt household activities and discourage people from using them. Several manufacturers offer low-noise fans to minimize this problem. Spot ventilation designs that require mounting fans on walls and ceilings can be modified to use fans that can be mounted in-line in the duct between the living space and the exterior, or on the roof or outside wall and connected to the room by a duct. The space between the in-line or exterior-mounted fan and the interior reduces the noise level in the house.

SPOT VENTILATION ISSUES

Spot ventilation may contribute to unacceptable radon levels inside the house if fan operation draws in radon-contaminated air via leaks in the floor, although this is less an issue for intermittent fan operation. Local codes or building officials should be able to indicate whether radon levels are an issue. Sealing leaks in the floor is an essential first course of action. If this is not sufficient to reduce radon pollution to acceptable levels, a radon mitigation system and/or a supply-only or balanced whole-house ventilation system may be necessary. See <http://www.epa.gov/iaq/radon/construc.html> for additional information.

Operation of spot ventilation exhaust fans can induce backdrafting—spillage of flue gases from combustion appliances (e.g., furnace, water heater, fireplace) into the living space—primarily when atmospheric or natural-draft flues are used rather than powered combustion systems. Elevated concentrations of pollutants in flue gases can pose serious health hazards. When using natural gas appliances, these problems can be avoided by

- using sealed-combustion models or models with power-vented exhausts,
- installing natural-draft combustion units in airtight mechanical enclosures that are vented to the outside, or
- placing natural-draft combustion units outside the conditioned space.

FAN TYPES

Ceiling-mounted—Ducted, ceiling-mounted fans common in bathrooms have capacities ranging from 50 to over 200 cfm.

Through-the-wall—Kitchens, baths, and some laundry areas have historically used through-the-wall fans to directly exhaust indoor air to the outdoors. These are simple but often not airtight when closed. Capacities range from 175 to over 500 cfm.

Kitchen range hood—Kitchen range fans capture pollutants and moisture generated by cooking and exhaust to the outdoors. Standard, updraft range hood units come efficiently positioned to make them most effective, are competitively priced, and use little total energy. Ductless recirculating units do not control moisture or other pollutants and should be avoided. Surface-mounted or snorkel (pop-up) downdraft units, popular for their convenience, tend to be costlier and less effective than overhead units.

SPOT VENTILATION

BATH AND KITCHEN VENT FANS

Spot ventilation fans in the bathroom and kitchen are critical because these locations are where the most moisture and odors are created.

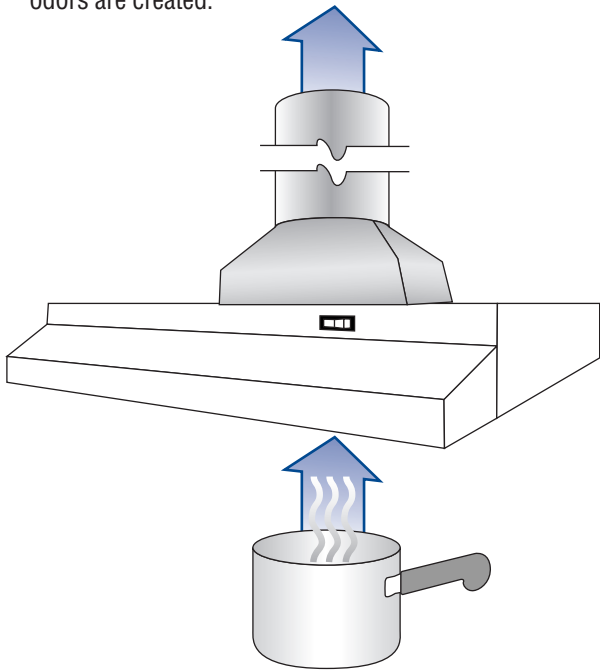
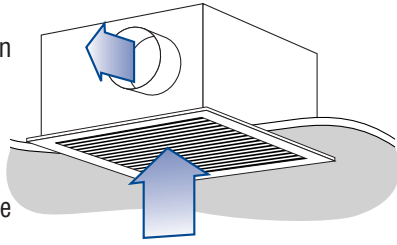

Overhead residential range fan capacities range from 100 to 300 cfm, while capacities of downdraft systems can be several times higher.

In-line—In-line fans are installed in duct runs between the ventilated area and the outdoor termination. Their purchase and installation costs are typically higher than for ceiling-mounted fans. However, remote mounting in attic spaces, for instance, makes in-line fans quieter within the living space than some other fan types. In-line fans are available in capacities of 70 cfm and higher.

Central multipoint—Central multipoint fans have multiple duct connection points that are useful primarily for whole-house ventilation systems. They can be used, though, to let one fan ventilate two or more bathrooms, for instance. Capacities range from 100 to over 400 cfm.

FAN CONTROL SWITCHES

Fan controls can be simple switches activated manually. For bathroom fans, operation by timers, humidity sensors, or other controls are preferred.

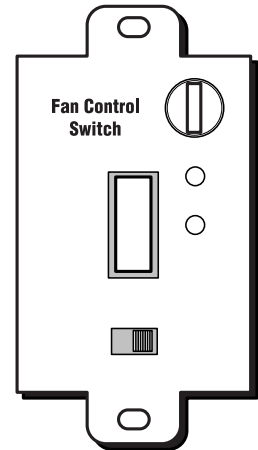

CONTROLS

On-off switches—On-off switches simply open or close a fan's electrical circuit. Manual on-off switches allow occupants to run spot-ventilation fans when they think ventilation is needed. Although this may be fine for range hood fans, other controls offer better targeting of high-pollutant time periods simply and efficiently for bathrooms. When occupants cannot be relied upon to run the bath fan, one alternative using a manual on-off switch and a quiet bath fan is to wire both the bath fan and bath light together so that the fan runs whenever the light is on.

Manual timers—Timers are switches activated by occupants that allow the fan to operate 20 minutes or more before turning off automatically. Timers are useful in bathrooms for improved moisture removal after showering, for example.

Humidity sensors—A humidistat (or dehumidistat) controls ventilation using humidity sensors. A humidistat makes an excellent bath fan control because it runs the fan until acceptable humidity levels are reached.

Motion sensors—Motion sensors detect occupancy within a room, but occupancy is not usually a good indicator of the need for spot ventilation.

Time controllers—Timer controllers are sophisticated devices used to control the times when mechanical ventilation systems operate. Time controllers can activate a spot ventilation fan at certain times each day to increase overall ventilation.

Boost controllers—Boost controllers allow a fan running continuously at low speed as part of a whole-house ventilation system to be temporarily boosted to a higher speed when an occupant wants spot ventilation.

SPOT VENTILATION

For more information, contact:

**Energy Efficiency and
Renewable Energy
Clearinghouse (EREC)**
1-800-DOE-3732
www.eren.doe.gov

Or visit the Building
Technologies Program
Web site at
www.buildings.gov

Or refer to Understanding
Ventilation: How to Design,
Select, and Install Residential
Ventilation Systems
The Healthy House Institute
812-332-5073
www.hhinst.com

Written and prepared for
the U.S. Department of
Energy by:

NAHB Research Center
800-898-2842
www.nahbrc.org

Southface Energy Institute
404-872-3549
www.southface.org

**U.S. Department of Energy's
Oak Ridge National
Laboratory**
Buildings Technology Center
865-574-5206
www.ornl.gov/btc

**U.S. Department of Energy's
National Renewable Energy
Laboratory**
303-275-3000
www.nrel.gov/buildings

NOTICE: Neither the United States government nor any agency thereof, nor any of their employees, makes any warranty, express or implied, or assumes any legal liability or responsibility for the accuracy, completeness, or usefulness of any information, apparatus, product, or process disclosed. The views and opinions of authors expressed herein do not necessarily state or reflect those of the United States government or any agency thereof.

DESIGN SPECIFICATIONS

✓ CAPACITY REQUIREMENTS

Bath fans should be sized to provide the larger of 50 cfm or 8 ACH in the bathroom. The required cfm capacity to provide 8 ACH can be calculated by multiplying the volume of the bathroom in cubic feet by 8 and dividing by 60.

Kitchen range hood fans should have a capacity of at least 100 cfm or 40 cfm per linear foot of hood, whichever is larger. For peninsula or island ranges, the fan capacity should be based on the combined length of the exposed three or four sides of the hood. If the hood is more than 27" above the range surface, the capacity should be increased.

The capacity of both bath and range hood fans is typically provided at 0.1" and 0.25" of static pressure to account for different duct types, duct length, duct configuration (number of turns and elbows), and exhaust termination. See the fan manufacturer's recommendations to determine the fan's capacity based on these duct characteristics. Generally, the capacity at 0.25" should be used. The capacity at 0.1" is usually appropriate only if the duct is smooth, straight (one elbow or less), and less than 15' in length. If the duct is longer than 15', has a diameter of less than 4", requires the use of multiple elbows, and/or uses corrugated duct material, the capacity achieved in the actual installation may be less than even the 0.25" capacity rating.

✓ EFFICACY

Fan efficacy refers to the energy needed to move a specified amount of air. To calculate fan efficacy, divide fan capacity (in cfm) by power consumption (in watts)—the larger the ratio the better. Both capacity and power consumption values are available from the manufacturer's literature or the product container. Consider the use of Energy Star® rated fans to reduce operation costs. To receive the Energy Star label, small bath fans (up to 75 cfm) must achieve 1.4 cfm/W or higher and larger bath fans and range hoods up to 500 cfm must achieve at least 2.8 cfm/W.

✓ NOISE

Noise is a major reason people avoid using ventilation fans. Small bathroom fans (less than 76 cfm) must have sound levels of no more than 2.0 sones to be labeled as Energy Star compliant; large bathroom fans must have sound levels of no more than 1.5 sones. Bath fans with noise levels of 1 sone or less are also available and should be considered to eliminate noise problems.

To receive the Energy Star label, range fans must have sound levels of no more than 4.0 sones. The quietest kitchen range hoods are rated at less than 2 sones. If multi-speed fans are used, be sure that the sound level at the high speed is 4 sones or less.

Remotely mounted fans are not typically sound-rated because various factors affect the perceived interior sound levels.

INSTALLATION

✓ MOUNTING

Seal gaskets and fan housings mounted on ceilings or walls. In insulated assemblies, do not use fans that are not rated for insulation contact.

✓ DUCTS

The most efficient fan ducts are smooth, short, straight, and properly sized. Smooth sheet metal ducts offer low airflow resistance. Because corrugated ducts have greater flow resistance, it is important to keep them as short as possible—stretch the corrugated material to its full length and cut off excess. Minimize the number of elbows. Seal joints with duct mastic. To inhibit condensation problems in unheated spaces, insulate the ducts and slope the ducts away from the fan. Ducts should match or exceed the fan duct fitting size.

✓ DUCT TERMINATION

Ducts expelling water vapor or other pollutants must exhaust directly to the exterior—never into attics or crawl spaces prone to moisture problems. Use wall caps or roof jacks with flap dampers, screens, or both to deter access. Unless they are already integrated into the system (e.g., wall cap with flapper), equip ventilation ducts with backdraft dampers at or near the insulated building boundary to reduce infiltration.



Printed with a renewable-source ink on paper containing at least 50% wastepaper, including 20% postconsumer waste.

December 2002 DOE/GO-102002-0786